

United States Department of the Interior
National Park Service

National Register of Historic Places Registration Form

This form is for use in nominating or requesting determinations for individual properties and districts. See instructions in National Register Bulletin, *How to Complete the National Register of Historic Places Registration Form*. If any item does not apply to the property being documented, enter "N/A" for "not applicable." For functions, architectural classification, materials, and areas of significance, enter only categories and subcategories from the instructions. Place additional certification comments, entries, and narrative items on continuation sheets if needed (NPS Form 10-900a).

1. Name of Property

Historic name Trinity Lutheran Church Historic District

Other names/site number N/A

Name of related Multiple Property Listing Rural Church Architecture of Missouri, c. 1819 to c. 1945

2. Location

Street & number 13007-13013 Route C

N/A	not for publication
-----	---------------------

City or town Russellville

N/A	vicinity
-----	----------

State Missouri Code MO County Cole Code 051 Zip code 65074

3. State/Federal Agency Certification

As the designated authority under the National Historic Preservation Act, as amended,
I hereby certify that this nomination request for determination of eligibility meets the documentation standards for registering properties in the National Register of Historic Places and meets the procedural and professional requirements set forth in 36 CFR Part 60.
In my opinion, the property meets does not meet the National Register Criteria. I recommend that this property be considered significant at the following level(s) of significance:
 national statewide local
Applicable National Register Criteria: A B C D

Signature of certifying official/Title _____ Date 1/13/20
JP 01/13/20
Missouri Department of Natural Resources
State or Federal agency/bureau or Tribal Government

In my opinion, the property meets does not meet the National Register criteria.
Signature of commenting official _____ Date _____
Title _____ State or Federal agency/bureau or Tribal Government

4. National Park Service Certification

I hereby certify that this property is:
 entered in the National Register determined eligible for the National Register
 determined not eligible for the National Register removed from the National Register
 other (explain:) _____
Signature of the Keeper _____ Date of Action _____

Trinity Lutheran Church Historic District
Name of Property

Cole County, Missouri
County and State

5. Classification

Ownership of Property
(Check as many boxes as apply.)

Category of Property
(Check only **one** box.)

Number of Resources within Property
(Do not include previously listed resources in the count.)

<input checked="" type="checkbox"/>	private
<input type="checkbox"/>	public - Local
<input type="checkbox"/>	public - State
<input type="checkbox"/>	public - Federal

<input type="checkbox"/>	building(s)
<input checked="" type="checkbox"/>	district
<input type="checkbox"/>	site
<input type="checkbox"/>	structure
<input type="checkbox"/>	object

Contributing	Noncontributing	
4	1	buildings
1		sites
	2	structures
		objects
5	3	Total

Number of contributing resources previously listed in the National Register

N/A

6. Function or Use

Historic Functions

(Enter categories from instructions.)

Religion: Religious facility

Religion: Church-related residence

Religion: Church school

Social: meeting hall

Current Functions

(Enter categories from instructions.)

Religion: Religious facility

Religion: Church-related residence

Social: meeting hall

7. Description

Architectural Classification

(Enter categories from instructions.)

Late Victorian: Romanesque

Materials

(Enter categories from instructions.)

foundation: Stone; Concrete

walls: Brick

roof: Asphalt

other: Metal

NARRATIVE DESCRIPTION ON CONTINUATION PAGES

Trinity Lutheran Church Historic District
Name of Property

Cole County, Missouri
County and State

8. Statement of Significance

Applicable National Register Criteria

(Mark "x" in one or more boxes for the criteria qualifying the property for National Register listing.)

- A Property is associated with events that have made a significant contribution to the broad patterns of our history.
- B Property is associated with the lives of persons significant in our past.
- C Property embodies the distinctive characteristics of a type, period, or method of construction or represents the work of a master, or possesses high artistic values, or represents a significant and distinguishable entity whose components lack individual distinction.
- D Property has yielded, or is likely to yield, information important in prehistory or history.

Criteria Considerations

(Mark "x" in all the boxes that apply.)

Property is:

- A Owned by a religious institution or used for religious purposes.
- B removed from its original location.
- C a birthplace or grave.
- D a cemetery.
- E a reconstructed building, object, or structure.
- F a commemorative property.
- G less than 50 years old or achieving significance within the past 50 years.

STATEMENT OF SIGNIFICANCE ON CONTINUATION PAGES

Areas of Significance

Architecture

Period of Significance

1911-1947

Significant Dates

1911-12

1939; 1947

Significant Person

(Complete only if Criterion B is marked above.)

N/A

Cultural Affiliation

N/A

Architect/Builder

Linhardt, Ben H.

Sprouse, Oliver

Inman, Ben

Eggers, George

9. Major Bibliographical References

Bibliography (Cite the books, articles, and other sources used in preparing this form.)

Previous documentation on file (NPS):

- preliminary determination of individual listing (36 CFR 67 has been requested)
- previously listed in the National Register
- previously determined eligible by the National Register
- designated a National Historic Landmark
- recorded by Historic American Buildings Survey # _____
- recorded by Historic American Engineering Record # _____
- recorded by Historic American Landscape Survey # _____

Primary location of additional data:

- State Historic Preservation Office
- Other State agency
- Federal agency
- Local government
- University
- Other

Name of repository: _____

Historic Resources Survey Number (if assigned): _____

Trinity Lutheran Church Historic District
Name of Property

Cole County, Missouri
County and State

10. Geographical Data

Acreeage of Property 4.2 acres

Latitude/Longitude Coordinates

Datum if other than WGS84: _____
(enter coordinates to 6 decimal places)

1 38.508590 -92.438010 3 _____
Latitude: Longitude: Latitude: Longitude:

2 _____ 4 _____
Latitude: Longitude: Latitude: Longitude:

UTM References

(Place additional UTM references on a continuation sheet.)

_____ NAD 1927 or _____ NAD 1983

1 _____ 3 _____
Zone Easting Northing Zone Easting Northing

2 _____ 4 _____
Zone Easting Northing Zone Easting Northing

Verbal Boundary Description (On continuation sheet)

Boundary Justification (On continuation sheet)

11. Form Prepared By

name/title Roger Jungmeyer, PhD, Professor of History; Lincoln University; Tiffany Patterson; Edited by Michelle Diedrich, MO SHPO
organization _____ date 23 September 2019
street & number 1103 Moreau Drive telephone 573-681-5223
city or town Jefferson City state MO zip code 65101
e-mail rjung@lincolnu.edu

Additional Documentation

Submit the following items with the completed form:

- **Maps:**
 - A **USGS map** (7.5 or 15 minute series) indicating the property's location.
 - A **Sketch map** for historic districts and properties having large acreage or numerous resources. Key all photographs to this map.
- **Continuation Sheets**
- **Photographs**
- **Owner Name and Contact Information**
- **Additional items:** (Check with the SHPO or FPO for any additional items.)

Paperwork Reduction Act Statement: This information is being collected for applications to the National Register of Historic Places to nominate properties for listing or determine eligibility for listing, to list properties, and to amend existing listings. Response to this request is required to obtain a benefit in accordance with the National Historic Preservation Act, as amended (16 U.S.C.460 et seq.).

Estimated Burden Statement: Public reporting burden for this form is estimated to average 18 hours per response including time for reviewing instructions, gathering and maintaining data, and completing and reviewing the form. Direct comments regarding this burden estimate or any aspect of this form to the Office of Planning and Performance Management. U.S. Dept. of the Interior, 1849 C. Street, NW, Washington, DC.

Trinity Lutheran Church Historic District
Name of Property

Cole County, Missouri
County and State

Photographs

Submit clear and descriptive photographs. The size of each image must be 1600x1200 pixels (minimum), 3000x2000 preferred, at 300 ppi (pixels per inch) or larger. Key all photographs to the sketch map. Each photograph must be numbered and that number must correspond to the photograph number on the photo log. For simplicity, the name of the photographer, photo date, etc. may be listed once on the photograph log and doesn't need to be labeled on every photograph.

Photo Log:

Name of Property: Trinity Lutheran Church
City or Vicinity: Russellville
County: Cole State: Missouri
Photographer: Samuel Schnieders; Roger L. Jungmeyer
Date Photographed: June-July 2019; September 2019

Description of Photograph(s) and number, include description of view indicating direction of camera:

- 1 of 20: Trinity Lutheran Church, Parsonage and Parish Hall, looking west southwest.
- 2 of 20: Trinity Lutheran Church Parish Hall, Parsonage and Garage, looking east southeast.
- 3 of 20: Trinity Lutheran Church, north façade, looking south.
- 4 of 20: Trinity Lutheran Church, south and east elevations, looking northwest.
- 5 of 20: Trinity Lutheran Church, interior, looking south.
- 6 of 20: Trinity Lutheran Church, interior, altar, looking south.
- 7 of 20: Trinity Lutheran Church, interior, west wall, looking west.
- 8 of 20: Trinity Lutheran Church, interior, looking north.
- 9 of 20: Parsonage, looking south southwest.
- 10 of 20: Parsonage and prayer garden, looking east.
- 11 of 20: Non Contributing garage, looking north, parking lot in foreground.
- 12 of 20: Parish Hall, looking south southwest.
- 13 of 20: Parish Hall, interior, first floor looking south.
- 14 of 20: Parish Hall, interior, basement, looking south.
- 15 of 20: Schoolhouse, looking northeast.
- 16 of 20: West and rear of parish hall, west elevation of garage, parking lot entrance looking east.
- 17 of 20: Noncontributing pavilion, looking south.
- 18 of 20: Playground equipment looking east southeast.
- 19 of 20: Greenspace/field area behind church and parsonage, looking north.
- 20 of 20: Greenspace/field area behind church looking north.

Figure Log:

- Figure 1: Exterior Photo Angle Map
Figure 2: Plat Map of Russellville, Mo. From *Standard Atlas of Cole County, Missouri*. Chicago: Geo. A. Ogle & Co., 1914.
Figure 3: Early Route C, Russellville, looking west with church in background
Figure 4: Church under construction, 1911
Figure 5: Church Dedication, 1912
Figure 6: Children Outside School, c. 1925
Figure 7: Sketch Floorplan of Trinity Lutheran Church and interior photo angles
Figure 8: Sketch Floorplan, first floor parsonage
Figure 9: Sketch Floorplan, Parish Hall
Figure 10: Site Map
Figure 11: District Map
Figure 12: St. Paul's Lutheran Church, Lohman, Missouri

National Register of Historic Places
Continuation Sheet

Section number 7 Page 1

Trinity Lutheran Church Historic District
Name of Property
Cole County, Missouri
County and State
Rural Church Architecture of Missouri, c. 1819 to c. 1945
Name of multiple listing (if applicable)

Summary:

The Trinity Lutheran Church Historic District is located at 13007-13013 Route C in Russellville, Cole County, Missouri (Figure 10). The church is representative of the twin-tower church type as described in the "Rural Church Architecture of Missouri, c. 1819 to c. 1945" Multiple Property Documentation Form (MPDF). The brick Romanesque Revival church has a steeply pitched center gable with a large round arched stained glass window. The center gable is flanked by a tower on either side, each of different heights. The ground floor of each tower has a round arch entrance door with a tall narrow 1/1 round arched window above. While the MPDF does not include districts as a property type, it does note the importance of intact complexes, notably those that have parish halls, parsonages and schools. Trinity Lutheran Church is the center of a small district of church-related buildings all constructed between 1911 and 1939. This district includes the church (1912), brick Craftsman style bungalow parsonage (1911), frame one-room schoolhouse (1912), a brick gable-front parish hall (1939) and the greenspace/field area. All resources have undergone changes and updates since the period of significance, including modern intrusions, rear additions and interior renovations. However, these changes do not significantly impact the historic character of the district nor the character defining architectural features of the buildings. Architect Ben H. Linhardt designed two of the four buildings, the church and the parsonage, though construction contracts for builders varied by building. There are three non-contributing resources: a pyramidal roof two-car garage built in 1978 that blends with the district, a gable roof pavilion (1992) in the greenspace/field area behind the parish buildings, and the modern parking lot (2005). Both the garage and pavilion were built after the district's period of significance. The significant interior changes to the church in 1947 are used as the end of the period of significance (1911-1947). This period still relates to the MPDF because the c. 1945 date does not indicate an exact end of the period of significance for rural church architecture in the state, but an approximate one.

Setting:

Resource letters "(A-F)" correspond to the Individual Resource Descriptions and the Figure 11 District Map.

The Trinity Lutheran Parish complex is located on the southern edge of Russellville. The 4.23 acre property lies south of Route C, with Smith St. as the western boundary. The southern boundary of the district is defined by a row of trees north of Bethany Court. Similarly the western boundary is defined by trees and the driveway of the property along Smith Street to the west off Route C (See Figure 10).

Within the nominated boundary, the three largest buildings of the complex (church (A), parsonage (C) and parish hall (E)) face north on to Route C and are closely spaced with green lawns and scattered trees. (See photos 1 and 2) A non-historic landscaped prayer garden is located in a large grassy area between the parsonage and the parish hall. (See photo 10) It has a curving concrete sidewalk and stone benches with landscaping and flowers. The resources in the prayer garden are considered small in scale, such as the pathway and benches, or temporary in nature such as the landscaping, thus they are not included in the resource count.

National Register of Historic Places
Continuation Sheet

Section number 7 Page 2

Trinity Lutheran Church Historic District
Name of Property
Cole County, Missouri
County and State
Rural Church Architecture of Missouri, c. 1819 to c. 1945
Name of multiple listing (if applicable)

Behind these buildings are the schoolhouse (B), non-historic garage (D), and a large non-historic concrete parking lot (G) that extends from S. Smith Street on the west to behind the church on the eastern edge of the property (Photos 11, 15, 16).

South of the parking lot is a large open greenspace/field area (H) historically owned and used by the church, only part of which is consistently mown. The maintained area of the northern section, features a non-historic gable roof pavilion (F). South of the pavilion is a small playground with swing set and climbing structure. (Photos 17-19) The playground is considered temporary in nature and is not included in the resource count. It consists of a small woodchip area boxed in by railroad ties. In the center is a small jungle gym. Outside of this on the grass, is a wooden swing set (Photo 18).

Outside of the boundary, the complex is located in a semi-residential area just at the southeast edge of the community. To the north are modest residences from the early to mid-1900s. A large vacant lot lies just to the west and immediately to the south is located the mid-century Cole County R-1 School. To the immediate south of the complex are residences and to the west the setting begins to turn to farmland as the city boundaries come to an end. Approximately one-half mile to the southeast along Route AA is the Trinity Lutheran Church cemetery. Originally established in 1896, the cemetery is 2.5 acres and remains an active cemetery. Though historically associated, the cemetery is not included as part of the historic district due to distance and the number of modern internments.

Individual Resource Descriptions
(See Figure 11 District Map)

A. Trinity Lutheran Church (contributing building), 1912

Photos 1, 2-8

Architect: Ben H. Linhardt

Builders: Ben Inman and Oliver Sprouse

Trinity Lutheran Church is an example of the twin tower church property type as described in "Rural Church Architecture of Missouri c. 1819 to c. 1945." The church has brick bearing walls (three bricks thick) with a stone foundation. The footprint is 75' in length and 37' in width. As noted in the MPDF the character defining features are the towers at the east and west corners of the front elevation.¹ The towers flank a center bay with a steeply pitched gable roof clad in composite shingles. Heavy brick corbeling outlines the gable. Rising the equivalent of two stories is a round arch stained glass window. The window consists of three stained and leaded glass panels on the lower level topped by a stone lintel carved with "EV. LUTH. CHURCH." Above the stone are three additional wood framed rectangular window panels topped by a half round window with thick wooden mullions separating the glass panels.

¹ Patterson, Tiffany "Rural Church Architecture of Missouri, c. 1819 to c. 1945." National Register of Historic Places Multiple Property Documentation Form, 2011., Section F, Page 17.

National Register of Historic Places
Continuation Sheet

Section number 7 Page 3

Trinity Lutheran Church Historic District
Name of Property
Cole County, Missouri
County and State
Rural Church Architecture of Missouri, c. 1819 to c. 1945
Name of multiple listing (if applicable)

The east and west towers give the church its character defining features as a twin tower church type. The eastern bell tower is 65' in height. It has an entrance door (north) at the ground level accessed by a low concrete stoop. The metal four-panel door is topped by a round arched stained and leaded glass window. The entryway is surrounded with decorative brickwork, including three header row surrounds over the round arched transom. Tall narrow buttresses extend along each corner of the tower on both the north and east sides. A similar door with a round arched stained leaded glass window is also located on the east side of the bell tower. The second floor of the tower is denoted by tall narrow round arched stained and leaded glass windows on the north and east. These windows measure 7' in height by 2' 5" in width. At the third level are stained glass oculus windows on three sides. The windows measure 30" in diameter. The east tower is topped by a frame steeple holding the bells behind louvered openings. The louvers were a non-historic alteration made in 1981. The roof of the steeple is clad in original stamped metal shingles and topped by a cross.

The west tower is shorter with a height of 34'. An entrance door is nearly identical to that of the east tower, though it has a 20 panel door instead of a four panel one. The second story windows, facing north and west, are identical to those in the east tower. The hipped and slightly flared roof of this tower is also clad in stamped metal shingles.

The east and west elevations of the church are very similar. Each side has four wide window bays separated by small buttresses. Each window consists of three tall round arched stained glass panels with the center panel being slightly taller than the flanking windows. To the south are small square flat-roofed sections that flank the multi-sided apse on the rear of the building. The west wall has a round arch door accessing the sacristy. The wall is solid brick on the east.

The rear has a multi sided apse with a hipped half-roof connecting to the rear wall of the church sanctuary. The apse has a 31" oculus window. The small flat roof rooms on either side each contain a round arch stained and leaded glass window. There is an exterior basement access door for mechanical equipment to the east of the apse.

Interior (Figure 7, Photos 5-8):

The tower entrances access a narthex measuring 22' 1" in width and 7' in depth. Restrooms are located at the west side of the narthex. There are three narthex windows, facing north each measuring 5' 1" in height and 2' 3" in width. The center window has the Bible "Heilige Schrift" symbol and a small pane acknowledging the donors, M. Schubert and Louis Schneider. From the narthex there is a stairway leading to the balcony and two double entry doors to the nave. The nave doors are 6' 8" in height and 3' in width. In each door are multi-colored glass panes.

The nave is 48' 1" long and slightly sloping from the narthex to the chancel arch. The interior ceiling height is 22' 4" at the peak near the chancel arch. The center aisle leading to the altar is 3' 5" in width flanked by eleven benches along either side (east and west). Side aisles of 2' 1" are along both east and west sides of the nave. The benches are golden oak 12' in length, 31 ½" in height and 22" in depth. Along either side are four sets of art glass windows. The windows are in groups of three with center windows measuring 9' 1" in height and 23" in width.

National Register of Historic Places
Continuation Sheet

Section number 7 Page 4

Trinity Lutheran Church Historic District
Name of Property
Cole County, Missouri
County and State
Rural Church Architecture of Missouri, c. 1819 to c. 1945
Name of multiple listing (if applicable)

In each setting there are two flanking windows measuring 8' 3" in height and 23" in width. The windows have an identical design. Louis Schneider and Mike Schubert donated the art glass windows found throughout the church, which were installed as the church was completed.

There are two matching chandeliers in the Nave. The lamps and shades are original, marked B & H Co (Bradley and Hubbard Manufacturing Company), a company noted for such items. There are matching lights on both east and west walls of the nave, three on the west and four on the east.

On June 29, 1947, the interior of the church was rededicated after incorporation of the current iconography symbolizing the various tenets of the faith. These are located along the walls in the Crusaders shield and the various symbols at the apex of both east and west walls of the nave. The artists are listed as C.A. Christiansen and Mr. Stensby.²

The Chancel arch is 15' 2" in height and 11' 7" in width. From the nave there are two 8" steps at the platform to the apse. There are detachable communion rails for the front of the platform secured by recessed attachments. The distance from the chancel arch to the rear wall of the apse is 12' 10". The domed ceiling height of the apse, beyond the chancel arch is 16' 10". The chancel arch is painted with oak and rose leaves. Above the chancel arch facing the nave is the painting of Heinrich Hoffman's "Christ's Ascension," symbolizing eternity.³

The apse with the altar is domed in a semicircular fashion with a round 31" art glass window depicting a dove with leaf in mouth in the center wall directly behind the altar. This refers to the flood and symbolizes deluge, victory, and expectation of new life. The apse is 12' 10" in depth and 12' 4" wide. The apse is painted a light gray with a leaf design beginning at the base of the floor. Painted at the height of the apse is a radiant star with the words INRI (Iesus Nazarenus Rex Iudaeorum) below and centered on the back wall of the apse above the dove window. To the left of the dove window is the symbol of the chalice (bread and wine) and to the right is the symbol of the baptismal font.

The altar, the focal center of the church with the "Christ Blessing" statue was furnished by St. Luke's Institute of Milwaukee, Wisconsin.⁴ Of golden oak, the altar is 11' 1" in height, 6' 1" in width and 3' 1" in depth. Symbols on the altar are the Alpha and Omega on the front upper panels left and right with the messianic rose incorporated in the design of both. That theme continues with a single larger rose carved into the altar above each of the panels. Above the

² 1895-1955, Sixtieth Anniversary, Trinity Evangelical Lutheran Church, Russellville, Missouri, November 13 A.D. 1955, page 7.

³ 1895-1955, Sixtieth Anniversary, Trinity Evangelical Lutheran Church, Russellville, Missouri, November 13, A.D. 1955, page 7.

⁴ 100th Anniversary, Trinity Evangelical Lutheran Church, Russellville, MO, B-W Graphics, Versailles, Missouri, 1995, p. 61.

National Register of Historic Places
Continuation Sheet

Section number 7 Page 5

Trinity Lutheran Church Historic District
Name of Property
Cole County, Missouri
County and State
Rural Church Architecture of Missouri, c. 1819 to c. 1945
Name of multiple listing (if applicable)

partially recessed statue are the same carved rose depictions on the right and left with a larger rose immediately below the cross topping the altar. At the apex of the altar is the budded cross with arms terminating in the trefoil (trefoil), symbolizing the Holy Trinity. On the front center panel of the altar is a painting of the Lord's Supper. In the center of the altar is the Christ blessing statue partially recessed in the altar's main upper portion. The Alpha and Omega signify the first and last letters of the Greek alphabet; Rev. 22:13: "the first and the last...the beginning and the end." The cross on the altar center is the Latin cross with the IHS (Jesus Hominum Salvator) symbol appearing at the very center.

From the floor upward the colors are blended with stripes beginning with a darker hue at the lower level becoming lighter to give the impression of rising to the heights. In the colors used Trinity church references indicate that the yellow stands for the goodness of God; blue for truth and constancy; red for divine love; black for humility; and white for purity.⁵

The Sacristy, located on the southwest corner of the church, is 8' wide and 9' 4" long with a window facing south 7' in height and 2' 5" in width. Access is gained from the apse through a door 6' 10" in height and 2' 9" in width. Also, on the west is an exterior arched door 6' 8" in height and 2' 11" in width. The sacristy holds the liturgical vessels and vestments and also serves as the entry to the pulpit. (See Figure 7 for sketch of church floor plan)

Interior furnishings of the church was through donations at the time of construction by members of the parish.⁶ To the right of the Chancel Arch is the pulpit of golden oak in Octagon shape donated by August Sauer and Adam Ott. The pulpit is 7' 2" in total height including the corresponding octagon pedestal 3' 2" in height. The pulpit is 3' 11" in width and is accessed from the sacristy via a door 6' 8" in height and 2' 8" in width. The pulpit is covered by an ornate canopy, also octagon shaped, with the trefoil around all sides and topped by a budded rose cross. The panels on the pulpit are in keeping with the rose depiction used on the altar, chancel arch and throughout the nave. Facing the altar, to the left of the Chancel Arch, is the lectern from which the scripture readings are given. The lectern was built by Theodore and Walter Jungmeyer in 1945 for the Golden Jubilee.⁷

The baptismal font in golden oak matches the octagon design of the pulpit and was a gift of Henry Raithel. The font is octagon shape 4' 4" in total height, including the octagon pedestal of 2' and topped by a cross. Entering the church from the narthex the baptismal font is situated immediately to one's right. The baptismal font at this location signifies admission into the church

⁵ 1895-1955, Sixtieth Anniversary, Trinity Evangelical Lutheran Church, Russellville, Missouri, November 13, A.D. 1955, page 7.

⁶ 100th Anniversary, Trinity Evangelical Lutheran Church, Russellville, MO, B-W Graphics, Versailles, Missouri, 1995, "January 1, 1912," p. 61.

⁷ Golden Jubilee, 1895-1945, Trinity Evangelical Lutheran Church, Russellville, Missouri, November 11, 1945, no page numbers.

National Register of Historic Places
Continuation Sheet

Section number 7 Page 6

Trinity Lutheran Church Historic District
Name of Property
Cole County, Missouri
County and State
Rural Church Architecture of Missouri, c. 1819 to c. 1945
Name of multiple listing (if applicable)

through baptism. The octagon shaped font in a tradition of the faith would indicate this is to symbolize the new creation or regeneration. The design on the font is a series of shell symbols on the eight sides of the font symbolizing the Triune God into which one is baptized. The immediate focus however, upon entering the nave from the narthex is directed to the chancel arch and Altar, center front.

The large bell in the bell tower was donated by John Gemeinhardt, George Schneider, and John F. Strobel. The small bell was donated by the congregation of St. Paul's of Lohman.

Symbolism plays an important part in the design of Trinity Lutheran Church. Being a liturgical church it has inherited the use of symbols from the early church when such signs and symbols were used to explain the faith in pictures to those who could not read. These symbols throughout the church are a supplement to providing a visible sign for parishioners to proclaim their faith. These symbols are incorporated through both the iconography and the design of various other furnishings in the church. These images mean what those placing them intend or believe them as part of their faith to mean as noted in various church sources.⁸

On both the east and west walls of the nave are oak leaf borders leading to a crusader's cross and shield with a silver Star of Bethlehem. The oak leaf pattern shape is found throughout the church. As stated in the 1955 Sixtieth Anniversary history "An oak leaf border is found around the walls leading into a crusader's cross and shield into which is placed the Star of Bethlehem. The oak leaf symbolizes strength and shaped into a cross means in faith one gains strength."⁹ The cross and shield images are centered between each bank of triple art glass windows.

The base of the walls are painted a darker hue at the lower levels. The hue becomes lighter as one continues to the apex of the walls. At the apex the pattern of oak leaf continues with various symbols of faith incorporated in a smaller version of the shields depicted between the larger art glass windows.¹⁰ On the East wall from the entry to the nave to the chancel arch those symbols are: Alpha symbolizing the beginning; Omega symbolizing the end; Cross symbolizing redemption; and Baptismal font symbolizing baptism. In similar fashion, on the west wall the symbols are IHS, a Christogram coming from the first three letters of the Greek name of Jesus. In Latin the J and I are indistinguishable and the C and S are sometimes interchangeable. Also depicted are the Circle symbolizing eternity; triangle symbolizing the Trinity with each side representing a person, three persons co-equal; and the square

⁸ The Icon, History, Symbolism and Meaning, A Monastic Journal, Winter 2003, Vol. 16, No 2. Author Anonymous.

⁹ 1895-1955, Sixtieth Anniversary, Trinity Evangelical Lutheran Church, Russellville, Missouri, November 13, A.D. 1955, page 7.

¹⁰ 1895-1955, Sixtieth Anniversary, Trinity Evangelical Lutheran Church, Russellville, Missouri, November 13, A.D. 1955, page 7.

National Register of Historic Places
Continuation Sheet

Section number 7 Page 7

Trinity Lutheran Church Historic District
Name of Property
Cole County, Missouri
County and State
Rural Church Architecture of Missouri, c. 1819 to c. 1945
Name of multiple listing (if applicable)

symbolizing earthly life. On either side of these shields with symbol is again the messianic rose depiction. On the walls throughout the nave to the chancel arch the cluster of grapes are incorporated into the oak and messianic rose design. Grapes are known to symbolize the wine used in the Eucharist. Grapes are seen as positive as the wine derives from grapes which represent abundance and faith.

The feature of iconography is that it may be depicted in a simplified, schematic way by means of geometric forms; rectangles, ovals, triangles, demonstrating a heavenly order. This scheme may be seen throughout at Trinity. In church tradition dating from the time of the Byzantine Empire iconography was seen through various forms in mosaics and wall paintings especially. It was a tradition of sacred and liturgical art whose function is essentially spiritual. In words attributed to Photios Kontoglou, a renowned iconographer "Icons raise the soul and mind of the believer..."¹¹

Notable to the Trinity Lutheran Church is a Hinners Organ purchased for \$1,675.00 in 1931. The organ is an outstanding feature of the church as one enters the nave. To one's left (east) is the recently refurbished organ, center is the Altar, and to the right (west) the pulpit rising on a pedestal and covered by an ornate canopy. This arrangement provides a symmetry to the Nave as ones attention is drawn to the front of the church. The Hinners Organ Company was located in Pekin, Illinois manufacturing organs especially for the smaller rural churches. Existing records indicate that the majority of organs were sold in the Midwestern states.¹² The organ at Trinity is the Hinners Electro Pneumatic Pipe Organ, Style FF-A. The arch at the organ in which the pipes are located is 13' 1" in height and 7' 8" in width. The organ has two manuals and three ranks of pipes consisting of two hundred nineteen pipes.¹³

The balcony is accessed by stairs from the narthex. The stairwell is fifteen steps and a width of 2' 8." The balcony ceiling, a continuation of that in the nave is 8' 5". The balcony is 31' 6" wide and 17' 3" in depth with eleven oak benches at 9' 2" long, 32" high and 19" deep. Windows in the balcony face north and are designed in an arch fashion. There are three windows 5' in height and 2' 3" wide. Arched above these are four trapezoid shaped windows with the base being 12", the sides 27" and the top 32." There is one center arched window 14" in height and 2' 3" in width. There are access doors from the balcony to both the east and west towers with the east providing entrance to the bell tower.

¹¹ "The History and Symbolism of Iconography," Monastery Icons, Westchester, Ohio, 2019.

¹² "The Hinners Organ Story" Colberd, Robert E. Jr., The American Organ, September 1960 p. 11.

¹³ Memorandum of Agreement, October 13, 1930, A. Hinners, Hinners Organ Co. President and O. Rossbach, A. Rossbach and Mrs. M. Schubert, Details of Construction.

National Register of Historic Places
Continuation Sheet

Section number 7 Page 8

Trinity Lutheran Church Historic District
Name of Property
Cole County, Missouri
County and State
Rural Church Architecture of Missouri, c. 1819 to c. 1945
Name of multiple listing (if applicable)

B. Schoolhouse (contributing building), 1912
Photo 14

This one-room frame building has a concrete foundation and asphalt shingle gable roof. It measures 18' 7" x 24' 7". A small bell tower 6' 8" high and 4' x 4' square sits at the peak on the east end of the building. While often depicted on the front of historic rural schoolhouses, the bell tower appears to be near the back of the building as historic photos depict classes on the west side of the building. The interior of the school was completely open with tables arranged throughout. The west end has an off-center entrance and no windows. A small vent is located near the peak. There are three evenly spaced windows on the south measuring 5' 5" in height and 2' 3" in width. The steeple bell from the school is located in the sign between the church and the parsonage. The structure remains in the original location immediately to the south of the church. Vinyl siding and soffits have been added to the building, but these do not take away from the defining characteristics of this small building.

C. Parsonage (contributing building), 1911
Photos 1-2, 9-10
Architect: Ben H. Linhardt
Builder: George Eggers

The parsonage was the first building to be constructed on the site. The church awarded the contract on May 11, 1911, and the house was completed by October with a total cost of \$1,837.95.¹⁴ The 1 ½ story brick house has a vaguely Craftsman design. It has a medium pitched front gable roof with large dormers on the east and west side. The gable end has paired 1/1 windows with a wide wood surround. Knee braces (brackets) support the wide wood eaves. Its façade has a full width shed roof porch supported by square brick pillars. A low knee wall surrounds the porch. An Ionic wood column centered in the porch is out of character with the Craftsman style, but was original to the building (seen in c. 1912 photos). The door is off center with paired windows to the west. Exterior changes are minimal but include installation of vinyl siding and soffits in the gable ends. The rear porch was also enclosed to create additional office/living space.

The parsonage is 28' 8" in width and 39' 1" in length with a back porch/office area at the rear measuring 12' 6" in depth x 21' 5" wide. A front porch on the north of the parsonage measures 24' x 10.' The roof is asphalt shingle and the foundation is concrete. There is a partial basement. The first floor contains a kitchen, dining room, living room, bedroom, office/family room, bathroom and laundry room. The second floor contains three bedrooms and a bathroom. (See Figure 8 for sketch of first floor floorplan).

¹⁴ Agreement May 11, 1911, between George Eggers and Lutheran Congregation of Russellville.

National Register of Historic Places
Continuation Sheet

Section number 7 Page 9

Trinity Lutheran Church Historic District
Name of Property
Cole County, Missouri
County and State
Rural Church Architecture of Missouri, c. 1819 to c. 1945
Name of multiple listing (if applicable)

D. Garage (non-contributing building), 1978
Photo 11, 16, 19

Located immediately south of the parsonage, the two-car garage constructed in 1978, is a square brick building with a pyramidal roof. A pedestrian door is located near the northeast corner. Small 1/1 windows are found widely spaced in the east and west walls. Two modern white paneled garage doors are on the south elevation. It is considered a non-contributing building as it was constructed after the period of significance.

E. Parish Hall (contributing building), 1939-1940
Photos 1, 11-13

The parish hall is a front gable brick building with asphalt shingle roof and a concrete foundation. It is one story with full basement. The steeply pitched front gable faces north and has corbeled brickwork along the roofline. It rises 27' 10" from ground to peak. A small round arched window/vent is located at the peak. Centered in the facade is a 10' wide by 7' deep gable roof foyer with paired entrance doors under a stone lintel. On the east and west walls of the foyer are 1/1 windows with concrete headers and sills. Flanking the foyer on the main block of the building are large window openings with concrete headers and sills. Once large paired windows, the openings have been infilled with smaller windows surrounded by stucco.

The east and west elevations are nearly identical with four widely spaced window bays separated by small brick buttresses. Like the front windows, the side windows have thick concrete headers and sills with smaller windows infilled surrounded by stucco. A slightly shorter brick addition was built on the south in 1975 to include an activity room on the first floor and a new kitchen in the basement. This addition matches the architectural design of the original structure in brick work and windows.

There is also a first floor entrance door on the southeast of the main block of the building. The first floor interior is an auditorium with stage on the south end. The stage has a curved front facing north and measuring 17' 7" wide and 15' 7" deep. There is storage below the stage. Access to the stage is gained from east and west side doors and also sets of four steps 2' in width on either side of the stage front.

Interior stairwells to the basement are located both to the north and south of the main floor. In the basement there are two entry doors one to the northwest and one to the southwest. These doors measure 6' 8" in height and 3' in width. The northwest door contains a window 24" in height and 27" in width while the southwest door contains a window 35" in height and 21" in width. In 1975 a new kitchen was constructed at the south end of the Parish Hall. The area is 22' 10" x 15' 10." Restrooms are located at the northeast end of the parish hall. There are eight basement windows located on the west measuring 4' 3" in height and 2' 7" in width.

National Register of Historic Places
Continuation Sheet

Section number 7 Page 10

Trinity Lutheran Church Historic District
Name of Property
Cole County, Missouri
County and State
Rural Church Architecture of Missouri, c. 1819 to c. 1945
Name of multiple listing (if applicable)

While the building has been altered, the original window openings are still evident. Also the addition is smaller and shorter than the original block of the building. Overall character defining features are evident and the hall contributes to the district. (See Figure 9 for sketch of floorplan)

F. Pavilion (non-contributing structure), 1992
Photo 17

Located south of the parking area, the pavilion was constructed in 1992 for outdoor activities and as a location for additional summer services. The structure is 31' 6" x 31' 6" with concrete floor. Square wooden posts support the gable roof. A swing set and climbing structure are located in a playground to the southeast of the pavilion. It is considered a non-contributing structure because it was constructed after the period of significance.

G. Parking Lot (non-contributing structure), (2005)
Photo 16

The parking lot is long and narrow with parking on the north side between the Parish Hall and the parsonage with a drive to the south. The lot widens behind the parsonage and church to permit parking on both the north and south borders. The lot can be accessed from Smith Street, or via a narrow drive off Rt. C just east of the church. It is considered a non-contributing structure because it was constructed after the period of significance.

H. Greenspace/Field (contributing site)
Photos 16-20

As noted in the Setting subsection above, a manicured greenspace extends directly behind the parking lot and becomes a field (as seen through the pavilion in Photo 17). It is approximately three acres in size, rectangular in shape, and is bounded on the south, east, and west by trees. This space has been associated with the property since the complex was constructed. (See "Lutheran Church Lot" in Figure 2) It has remained unimproved save for the parking lot (G), pavilion (F), and play area. However, these features are restricted to the northern portion of the site, on the regularly maintained part of the resource. The space still retains its open character, especially just south of the play area and is thus considered a contributing site.

Integrity

The district as a whole retains a high degree of integrity. The four primary buildings—church, school, parsonage, and parish hall look much as they did when constructed in 1911 to 1939. Specific historic and non-historic changes are noted in the individual property descriptions. The

National Register of Historic Places
Continuation Sheet

Section number 7 Page 11

Trinity Lutheran Church Historic District
Name of Property
Cole County, Missouri
County and State
Rural Church Architecture of Missouri, c. 1819 to c. 1945
Name of multiple listing (if applicable)

church may have seen the fewest exterior changes, limited to plexiglass coverings to protect the historic stained glass windows, wood louvers in the bell tower, and the installation of an ADA accessible ramp. Interior changes in the church, completed in 1947, post-date the church's construction but are significant to the historic character of the church and are within the period of significance of the district. The parsonage and parish hall have also seen some changes as the buildings have adapted to more modern use. Notably some modifications to siding and windows in the parsonage, and windows in the parish hall. While noticeable, these changes do not significantly detract from the character defining features of the two buildings, including brick walls, shaped window openings, and period/style indicating features such as decorative brickwork, columns and knee braces. The school building has seen the most change, with the addition of non-historic siding over original clapboards. However, the new siding does not modify the historically simple design of the school, which was essentially a small frame clapboard building with bell tower.

The grounds of the district have seen the most change over time. Structural additions include the construction of a pavilion (1992), and a garage (1978). These two structures are behind the three largest buildings on the site and are not readily seen from the "front" of the district along Route C. They are also relatively small in comparison to the contributing buildings in the district. The parking area behind the church and parish hall has always been part of the original district. The character of this area has changed with the addition of paving in 2005, so it is considered non-contributing to the district. The large greenspace/field acreage behind the church was part of the original land purchased for the district in 1907. For much of the period of significance, it was an open grassy lawn. More recent additions include an abandoned prayer garden (installed 2010) with small pathways and wooden crosses. This area is no longer maintained and has, for the most part, returned to a grassy lawn. The wood crosses remain (see photo 20), but do not significantly impact the integrity of the approximately 3 acre area.

National Register of Historic Places
Continuation Sheet

Section number 8 Page 12

Trinity Lutheran Church Historic District
Name of Property
Cole County, Missouri
County and State
Rural Church Architecture of Missouri, c. 1819 to c. 1945
Name of multiple listing (if applicable)

Summary:

The Trinity Lutheran Church Historic District, 13007 Route C, Russellville, Cole County, Missouri, is locally significant under National Register Criterion C in the area of Architecture. The church organized under the leadership of Pastor J. Paul Franke on September 1, 1895. The small congregation soon outgrew its original frame building and planned a new church complex including a church, parsonage, and schoolhouse. Ben H. Linhardt of Jefferson City, Mo. designed the church and parsonage, constructed in 1911 and 1912. He may have also designed the 1912 schoolhouse on the property. The parish hall was completed in 1939. A garage, constructed 1978, blends with the district but is non-contributing. A small pavilion, built in 1992 and also non-contributing, is located in the open lawn behind the church building complex. Finally, the parking lot was paved in 2005, and is the final non-contributing resource. The church is significant in Cole County as an example of the twin-tower church type as described in the "Rural Church Architecture of Missouri, c. 1819 to c. 1945" Multiple Property Documentation Form (MPDF). Statewide, the twin tower form is one of the least common church types, and can more often be found in urban rather than rural areas. As noted in the MPDF, associated church buildings in rural areas (schools, parsonages, parish halls, etc.) are increasingly rare.¹⁵ In 1947 the interior of the church was rededicated after completion of painting with the various symbols of the faith. The interior changes are considered significant under Criterion C for their high artistic value. The period of significance of the district is 1911 to 1947, a date range that includes the construction of the first contributing building through the interior church updates in 1947. The end date does not technically fall outside the end of the period of significance for rural church architecture in Missouri, since the MDPF dates are circa dates, indicating a small range of approximate dates around the beginning and end of the c. 1819 to c. 1945 period. Rural churches, notably Catholic and Lutheran congregations, were often centers of small complexes including schools, cemeteries, parsonages, and parish halls. As populations changed, auxiliary structures were often lost. Trinity, however, retains its original lot (including the undeveloped portion to the south), related parsonage, parish hall, and schoolhouse. The schoolhouse is now available for use as office and meeting space rather than its original function. These are all important features of historic rural church complexes and these resources are increasingly rare in rural areas of the state. The property meets the requirements of listing under Criterion Consideration A as the property derives primary significance from its architectural design rather than historic religious use.

Background:

Russellville is a rural community in southwestern Cole County, Missouri located about 17 miles from the county seat and State Capital in Jefferson City. Surveyed in 1838, the town boundaries expanded in the 1880s with the coming of the Lebanon branch of the Missouri Pacific Railroad. Devastated by a fire in January 1883, which destroyed much of the old town, the town rebuilt and much of its commercial and residential buildings date from after that period. The population hovered around 300 in the late 19th and early 20th century, growing to a peak of 869 people in the 1990 census.¹⁶ Today, the community is home to approximately 820

¹⁵ Patterson, Section F, Page 21.

¹⁶ United States Bureau of the Census, 1900, 1910, 1990.

National Register of Historic Places
Continuation Sheet

Section number 8 Page 13

Trinity Lutheran Church Historic District
Name of Property
Cole County, Missouri
County and State
Rural Church Architecture of Missouri, c. 1819 to c. 1945
Name of multiple listing (if applicable)

residents. This meets the definition of a rural church as defined by Section G of the Rural Church Architecture MPDF, in that it is located in a community with a population less than 2000 both currently and at the time it was founded.¹⁷

The early history, 1895-1897, of the Evangelical Lutheran Dreinigskeit Geminde Church (Trinity Lutheran Church), Russellville, Missouri, was written by Reverend J. Paul Franke and thereafter by Reverend Conrad Schaff who served as pastor from 1910-1923. These histories are recorded in Trinity Evangelical Lutheran Church, Russellville, Missouri, Records, 1895-1960; Chronik, pp. 393-400.¹⁸ This history dates the beginning of Trinity from September 1895. At that time the church was led by Pastor J. Paul Franke. Pastor Franke conducted services September 1, 1895, although the congregation was not yet fully organized. During the same time Trinity at Russellville was being organized he was serving a church at California, Missouri.¹⁹ Trinity Lutheran began its formation with the first baptism November 3, 1895. The first funeral and burial was October 28, 1895.²⁰

By 1896 plans for building both a church and parsonage began with the purchase of one acre of land within the then village of Russellville. Two acres of land were purchased from Franz Erhart, September 12, 1896, for a church cemetery and conveyed to M. Schubert and John Buchta, Trustees for the German Evangelical Lutheran Church.²¹ That land is located one-half mile from the present day church. The first church was built and dedicated September 13, 1896. Pastor Franke in his notes to the church paper stated "Russellville is located west of Jefferson City on a spur of the Missouri Pacific Railroad."²² The first church was a 24' x 36' frame building costing \$640.00 and located on the west side of Marion Street. Morning and afternoon services were held on the day of dedication. The morning service was conducted by Pastor Fikenscher, in German, with the afternoon service being conducted by Pastor J. Paul Franke in English.²³ By 1896 the congregation had approximately twenty members. The first recorded marriage was February 2, 1898. The first confirmation took place May 22, 1898, with a class of seven confirmands.²⁴

Pastor Franke served Trinity until 1897. Pastor F. Schardt then served as pastor for both the Russellville and California congregations until he became the resident pastor at Russellville in July, 1899. The congregation at that time made the decision to build a parsonage, a five room one story home, on the previously purchased one acre. The parsonage was completed by the

¹⁷ Patterson, Tiffany "Rural Church Architecture of Missouri, c. 1819 to c. 1945." National Register of Historic Places Multiple Property Documentation Form, 2011., Section G, Page 1.

¹⁸ Trinity Evangelical Lutheran Church, Russellville, Missouri, Records, 1895-1960, Chronik, pp. 393-400.

¹⁹ Ibid. p. 393

²⁰ Notes of Pastor J. Paul Franke, translated from the German, Church Record Book, pp. 393-394.

²¹ General Warranty Deed, September, 12, 1896, Franz Erhart to M. Schubert and John Buchta for the German Evangelical Lutheran Church.

²² Notes of Pastor J. Paul Franke, translated from the German, Church Record Book. Reference here is to the church paper no name given. This was most likely the "Kirchen-blatt der Evangelisch Lutherischen Synode von Iowa, the paper of the Iowa Synod of which Trinity was a member. The paper was published from 1886-1930 first as a semi-monthly then as a Biweekly from 1888-1930, p. 394.

²³ Notes of Pastor J. Paul Franke, Church Record Book, p. 394

²⁴ Notes of Pastor J. Paul Franke, translated from the German, Church Record Book, pp. 393-394.

National Register of Historic Places
Continuation Sheet

Section number 8 Page 14

Trinity Lutheran Church Historic District
Name of Property
Cole County, Missouri
County and State
Rural Church Architecture of Missouri, c. 1819 to c. 1945
Name of multiple listing (if applicable)

fall of 1899 for a cost of \$485.00.²⁵ Pastor Schardt led the congregation until 1905, when he was succeeded by Reverend Charles Schober. Pastor Schober served from 1905-1910. It was during Pastor Schober's tenure that in 1907, the congregation purchased four acres of land in three separate transactions in the southeastern section of Russellville at a total cost of \$1,049. This was to be the future site for a new parsonage and church.²⁶ There are General Warranty Deeds for the adjoining lots purchased dated January 24, 1907.²⁷ In 1910 Reverend Conrad Schaff came to serve the congregation. As the Trinity parish outgrew its facilities reaching a membership of two hundred fifty, in March 1911, the old church and property was sold for \$2,500.00.²⁸

Planning then began for construction of a new parsonage, church, and any additional structures needed on the four acres purchased in 1907. First, was the building of an eight room brick bungalow parsonage. The specifications for the parsonage were submitted by Ben H. Linhardt, architect, with the contract for construction awarded to George Eggers, May 11, 1911, for \$1,837.95.²⁹ Construction began in June 1911, and completion was marked with the dedication of the new parsonage October 1, 1911.³⁰

After letting the contract in May to build a parsonage, members of the congregation undertook in August 1911, planning for the construction of a new church. Ben H. Linhardt, submitted specifications for construction of the church to the Building Committee of Michael Schubert, Louis Schneider and Adam Ott.³¹ The walls were to be laid in Kansas Hydraulic Red Press Brick # 8 and all window and door sills to be the best quality Buff Bedford stone. Flooring was to be clear yellow pine with the roof to be of Dixie galvanized metal shingles. The steel ceiling in the nave is from the Wheeling Corrugating Company.³² The church was to be about 70 feet in length with two towers and two front entrances and built in "Roman Style."³³ It was noted in

²⁵ Notes of Pastor C. Schaff, Church Record Book, p. 395.

²⁶ Notes of Conrad Schaff, Pastor, Trinity Evangelical Lutheran Church, Russellville, Missouri, Records, 1895- 1960, Chronik, page 395.

²⁷ Three Deeds dated January 24, 1907. George J. Eggers; M. Schubert; George and Katie Schneider, Louis and Katie Schneider; General Warranty Deeds to Russellville Evangelical Lutheran Dreinegskeit Gemeinde Church. Complete listing in Bibliography. In the Church Record Book, Chronik, p. 395, the cost is given as \$1,050.

²⁸ Notes of C. Schaff, Pastor, Trinity Evangelical Lutheran Church, Russellville, Missouri, Records, 1895-1960, Chronik, page 396.

²⁹ Agreement of May 11, 1911 between George Eggers and Lutheran Congregation of Russellville, Mo. to erect a Lutheran Parsonage on Lots No. 12 and 13, Schuberts Addition, Village of Russellville, Missouri.

³⁰ Notes of Conrad Schaff, Pastor, Trinity Evangelical Lutheran Church, Russellville, Missouri, Records, 1895- 1960, Chronik, page 396. Russellville Weekly Rustler, September 29, 1911.

³¹ Specifications of the Material and Work Necessary in the Erection and Completion of the Church for the Evangelical Lutheran Congregation, Russellville, Missouri, 1911, Architect, Ben H. Linhardt, Jefferson City, Mo.

³² Specifications of the Material and Work Necessary in the Erection and Completion of the Church for the Evangelical Lutheran Congregation, Russellville, Missouri, 1911, Architect, Ben H. Linhardt, Jefferson City, Mo.

³³ Notes of Conrad Schaff, Pastor, Trinity Evangelical Lutheran Church, Russellville, Missouri, Church Record Book 1895-1960, Chronik, page 396.

National Register of Historic Places
Continuation Sheet

Section number 8 Page 15

Trinity Lutheran Church Historic District
Name of Property
Cole County, Missouri
County and State
Rural Church Architecture of Missouri, c. 1819 to c. 1945
Name of multiple listing (if applicable)

the Russellville Weekly Rustler that plans for the new church were to be submitted by Ben H. Linhardt, an architect from Jefferson City, Missouri.³⁴

The cornerstone for this new church was laid October 22, 1911. Reverend C. Bunge presided over the 11 a.m. cornerstone ceremony.³⁵ Among the articles placed in the stone were the history of the congregation, a Bible, Lutheran Catechism, several pieces of money, a copy of the "Kirchen-blatt", a church paper; and a copy of the Rustler.³⁶ The ceremony had been delayed from an earlier date due to weather. The contract for building the church went to Ben Inman and Oliver Sprouse of California, Missouri.³⁷ They signed the contract for erecting the church on October 25, 1911, for a cost of \$6,600.00. The contract specified that work was to be completed in 155 days from the date of the contract.³⁸ Ben Inman was the contractor to complete the brick work and Oliver Sprouse the woodwork for the church.³⁹

On August 4, 1912, a farewell service was held in the old church after which the congregation processed to the new church for the dedication. There were guest speakers for the morning service conducted in German, and in the afternoon, in English. Attendance for the dedication was estimated to be 1,200 to 1,500 with attendees from Jefferson City as well as surrounding communities.⁴⁰ The cost for the church and additional buildings was \$11,525.00 with a remaining debt of \$1,300.00.⁴¹ The additional buildings may have included the one room school house for which there is no construction information. Also a barn did exist until the 1960s, not unusual in a rural setting as the minister would have maintained a garden and some livestock. In the *Russellville Weekly Rustler*, April 7, 1916, the parsonage was noted as one of the best in Russellville and presents a pleasing appearance. In the same issue, reference to the Church was "this magnificent structure stands as one of the best and most substantially constructed country churches in Missouri."⁴²

In 1912, a one room school house was built and dedicated October 20, 1912. This served as the German school with instruction for a period of two years for nine months of the year from 9:00 a.m. to 3:00 p.m. Classes were conducted only in German. In time, as this schedule appeared to conflict with the public school curriculum, classes were changed to Saturday mornings.

³⁴ Russellville Weekly Rustler, August 4, 1911. Notes of C. Schaff, Church Record Book, Chronik, p. 396.

³⁵ Russellville Weekly Rustler, October 13, 1911. Notes of C. Schaff, Church Record Book, Chronik, p. 396.

³⁶ Russellville Weekly Rustler, October 13, 1911.

³⁷ Russellville Weekly Rustler, October 27, 1911.

³⁸ Agreement dated 25 October 1911 between the firm of O. E. Sprouse and Ben Inman, Contractor and Committee (Building) of the second part M. Schubert, A. Ott and Louis Schneider.

³⁹ 100th Anniversary, Trinity Evangelical Lutheran Church, Russellville, Mo, 1895-1955, B-W Graphics, Versailles, Missouri, 1995, p. 61.

⁴⁰ Russellville Weekly Rustler, August 9, 1912.

⁴¹ Notes of Conrad Schaff, Pastor, Trinity Evangelical Lutheran Church, Russellville, Missouri, Records, 1895-1960, CHRONIK, page 396.

⁴² Russellville Weekly Rustler, April 7, 1916.

National Register of Historic Places
Continuation Sheet

Section number 8 Page 16

Trinity Lutheran Church Historic District
Name of Property
Cole County, Missouri
County and State
Rural Church Architecture of Missouri, c. 1819 to c. 1945
Name of multiple listing (if applicable)

Land for the Parish Hall was donated by the estate of Michael Schubert.⁴³ Construction of the Parish Hall, a building 36' 2" by 74' began in November, 1939. At a cost of \$4,209.00 the hall included a basement and a main floor with an auditorium including a stage for performances. The Parish Hall was dedicated May 11, 1940, and remains in use, with improvements, today. Grounds for a Parish Cemetery of two acres were purchased from Franz Erhart in 1896 and are located approximately one-half mile from the church.⁴⁴ April 27, 1913, the congregation adopted a cemetery ordinance. An additional one-half acre was purchased April 27, 1939 from C.S. and Estella Glover.⁴⁵ January 4, 1948, at the Annual Meeting of the Congregation a special fund was created for purpose of maintaining the cemetery.⁴⁶ January 9, 1949, it was decided that the cemetery was to be platted.⁴⁷ January 9, 1955, at an Annual Meeting the decision was reached to construct a shelter house at the cemetery for storage and other items necessary for maintenance of the grounds. This was to be a structure 18' x 20' with a rock veneer to match the entrance rock design. Volunteers were to assist in the building to reduce the costs.⁴⁸ In 1983 the congregation approved establishing Trinity Lutheran Cemetery of Russellville, Inc. for purposes of long term maintenance of the cemetery grounds. Officers of the original board were Wilbert Schmoeger, Roy Goldammer, and Roy Pittrich.⁴⁹

Articles of Incorporation for the Church were filed with the State of Missouri June 17, 1914.⁵⁰ May 21, 1914, Trinity joined the Iowa Synod. By 1917 membership at Trinity stood at 279. Pastor Schaff departed in May 1923, and was followed by Reverend Otto Rossbach. Pastor Rossbach served until September 1944, departing due to ill health. During an interim period the congregation was served by Reverend J. Schiller. Reverend Schiller had served the congregation during the illness of Reverend Rossbach and continued to do so through 1944. In 1945 John Jacob Haberaecker became the pastor at Trinity. The congregation continued to grow and by 1955, the membership of Trinity was three hundred and eleven.

On June 29, 1947, the interior of the church was rededicated after repainting with the current iconography symbolizing the various tenets of the faith. These are located along the walls in the Crusaders shield and the various symbols at the apex of both east and west walls of the nave. The artists are listed as C.A. Christiansen and Mr. Stensby.⁵¹ Due to the high artistic value of the repainting, 1947 is considered a significant date.

⁴³ General Warranty Deed. Trustees of Michael Schubert Estate to William Schmoeger, Frank Ott, Julius Buchta trustees of Russellville Evangelical Lutheran Dreinegskheit Geminde Church for the sum of one dollar, December 5, 1939.

⁴⁴ General Warranty Deed, September, 12, 1896, Franz Erhart to M. Schubert and John Buchta for the German Evangelical Lutheran Church.

⁴⁵ General Warranty Deed, C. S. and Estella Glover to Evangelical Lutheran congregation, Russellville, Missouri, April 27, 1939.

⁴⁶ Minutes of the Annual Meeting of the Congregation, January 4, 1948.

⁴⁷ Minutes of the Annual Meeting of the Congregation, January 9, 1949.

⁴⁸ Minutes of the Semi-Annual Meeting of the Congregation, July 3, 1955.

⁴⁹ Minutes of the Annual Meeting of the Congregation, January 9, 1983.

⁵⁰ Articles of Incorporation and Pro Forma Decree, Evangelical Lutheran Trinity Congregation, June 17, 1914.

⁵¹ 1895-1955, Sixtieth Anniversary, Trinity Evangelical Lutheran Church, Russellville, Missouri, November 13, A.D. 1955, page 5.

National Register of Historic Places
Continuation Sheet

Section number 8 Page 17

Trinity Lutheran Church Historic District
Name of Property
Cole County, Missouri
County and State
Rural Church Architecture of Missouri, c. 1819 to c. 1945
Name of multiple listing (if applicable)

In 1949 altar rails and kneeling cushions were provided from memorial monies given by the Mrs. Michael Schubert and Fred Dampf families.⁵² In the 1970s a ramp and railings were added to the east side entrance of the church for accessibility. In 1978 a two car garage was constructed immediately south of the parsonage. Like the other major buildings the garage is constructed of red brick and does not detract from the site as a non-contributing structure. In 1992 a pavilion was built for use for outdoor activities as summer services and also as a gathering area. In 2005 the parking lot was paved.

In a congregational meeting January 11, 1953, it was approved that one German service per month would be at 9:30 a.m. followed by English, and another German service per month following the English service.⁵³ January 13, 1957, at the Annual Meeting of the Congregation it was approved that English would be used every Sunday at 10:00 a.m. with one German service per month prior to that of the English. Also there would be several German services per month following the English during the year.⁵⁴ In later years English became the only service offered.

Twin Tower Rural Church Architecture and Complexes in Cole County:

Trinity Lutheran connects closely to the twin-tower type as described in Rural Church Architecture of Missouri MPDF. It is located in a small town (under 2000 residents) in a historic community in southwestern Cole County, which is one of the defining qualities of a rural church per the MPDF.⁵⁵ The church is characterized by a gable flanked at each front corner by towers. As described in the property type, the towers project slightly from the façade though they are integrated into the main block of the building. Though some twin-tower churches have two identical towers, most like Trinity Lutheran, have towers of differing heights. Ornamentation is similar, though not identical. As is common to the type, one of the towers (east) is topped by a belfry and spire and the other by a steeply pitched hipped roof. Like many examples, the main roof of the church is gabled. While its floorplan is not as complex as some examples of the form, Trinity Lutheran does have a multi-room interior including the narthex, large sanctuary with balcony, and rooms to either side of the altar in the apse.⁵⁶

As noted in the twin-tower subtype significance section of the MPDF, twin-tower churches tend to be more “high style” compared to other rural church subtypes. They tend toward Revival styles such as Gothic and Romanesque. This is true for Trinity as its round and segmental arch windows are typical of the Romanesque Revival Style. Though the overall MPDF sampling for the type was small, most examples were associated with skilled builders or architects.⁵⁷ Trinity benefited from both, with its design by Ben H. Linhardt, and construction by master builder Oliver Sprouse. Sprouse (see brief biography at the end of Section 8) led construction on Trinity and several other churches in central Missouri.

⁵² 1895-1955, Sixtieth Anniversary, Trinity Evangelical Lutheran Church, Russellville, Missouri, November 13, A.D. 1955, page 5. Annual Meeting of the Congregation, January 9, 1949.

⁵³ Annual Meeting of the Congregation, January 11, 1953.

⁵⁴ Annual Meeting of the Congregation, January 13, 1957.

⁵⁵ Patterson, Section G, Page 1

⁵⁶ Pattereson, Section F, Pages 17-19

⁵⁷ Ibid.

National Register of Historic Places
Continuation Sheet

Section number 8 Page 18

Trinity Lutheran Church Historic District
Name of Property
Cole County, Missouri
County and State
Rural Church Architecture of Missouri, c. 1819 to c. 1945
Name of multiple listing (if applicable)

While the church and associated buildings have seen some change over time, the character defining features are extant and the building meets the registration requirements under the MPDF. It is a relatively pristine example of the type, with only minor modifications to the belfry and roofing materials. It retains its original exterior siding (brick), foundation (stone) and windows (stained glass installed at the completion of the church in 1912). It is “high style” representing the Romanesque Revival style, with associated round arch fenestration and decorative brickwork around doors and along the roofline. While the belfry openings have been infilled with louvers, this is a common alteration not considered a significant alteration under the registration requirements. The spire, belfry, and original openings are evident. The interior has seen the significant addition of decorative painting in the sanctuary, but little to no changes in the open space for the congregation that is characteristic of rural church types.

As noted in the MPDF, examples used to define the twin-tower subtype were often associated with prosperous congregations that created larger church complexes which could include parish halls, parsonages, schools and cemeteries.⁵⁸ Trinity retains its historic school, parsonage and parish hall. These extant resources are part of the historic complex and should be considered significant features of the twin-tower subtype. These resources, then, are counted as contributing to the district.

This is the only example of a twin-tower church in Russellville. Based on information available the church is a significant example of the type, not only in Russellville, but in Cole County. To date, there has been no systematic survey of residential, commercial, institutional or religious architecture in Cole County outside of Jefferson City, the county’s largest community. There are some references to historic churches, including historic photographs of approximately 30 churches spanning Jewish, Protestant and Catholic Congregations on the Cole County Historical Society website.⁵⁹ Of these, three (including Trinity Lutheran), were examples of the twin-tower subtype. One of these, the Christian Church in Jefferson City, however, falls outside the Rural Church Architecture of Missouri MPDF because it is located in an urban area. The only other known twin-tower type is the St. Paul’s Evangelical Lutheran Church in Lohman, Missouri constructed in 1923-24.

Both Trinity and St. Paul’s are good examples of the historic twin-tower church type, though each represent a different style. The St. Paul’s current church (completed in 1924) is the third iteration of building for the congregation (Figure 12). Trinity is somewhat unique in that its developmental history prior to the construction of the current building is relatively short. It organized in 1895 and by 1907 was planning for its current building. The building period of its three major facilities—church, parsonage and school—were also completed in one year. In contrast, St. Paul’s once had a parsonage and school dating to the 1880s with a new church in 1923. It also built an activity building in the 1990s. St. Paul’s school no longer exists, and the fate of its historic parsonage is unknown. Trinity Lutheran Church, Russellville, stands out as a complete rural church complex retaining its associated parsonage, school, and parish hall.

⁵⁸ Patterson, Section F, Page 21

⁵⁹ “Cole County Churches,” Cole County Historical Society and Museum website, <https://www.colecountyhistoricalmuseum.org/churches>. Accessed August 18, 2019.

National Register of Historic Places
Continuation Sheet

Section number 8 Page 19

Trinity Lutheran Church Historic District
Name of Property
Cole County, Missouri
County and State
Rural Church Architecture of Missouri, c. 1819 to c. 1945
Name of multiple listing (if applicable)

Trinity Lutheran Church, significance related to the 1947 Interior (Photos 5-8):

Trinity Lutheran Church is also significant due to the high artistic value of the interior of the church. On June 29, 1947, the interior of the church was re-dedicated after painting with the current iconography symbolizing the various tenets of the faith. These are located along the walls in the Crusaders shield and the various symbols at the apex of both east and west walls of the nave. The artists are listed as C.A. Christiansen and Mr. Stensby.⁶⁰

Symbolism plays an important part in the design of Trinity Lutheran Church. Being a liturgical church it has inherited the use of symbols from the early church when such signs and symbols were used to explain the faith in pictures to those who could not read. These symbols throughout the church are a supplement to providing a visible sign for parishioners to proclaim their faith. These symbols are incorporated through both the iconography and the design of various other furnishings in the church. These images mean what those placing them intend or believe them as part of their faith to mean as noted in various church sources.⁶¹

The chancel arch is painted with oak and rose leaves. Above the chancel arch facing the nave is the painting of Heinrich Hoffman's "Christ's Ascension," symbolizing eternity.⁶² The apse is painted a light gray with a leaf design beginning at the base of the floor. Painted at the height of the apse is a radiant star with the words INRI (Iesus Nazarenus Rex Iudaeorum) below and centered on the back wall of the apse above the dove window. To the left of the dove window is the symbol of the chalice (bread and wine) and to the right is the symbol of the baptismal font.

From the floor upward the colors are blended with stripes beginning with a darker hue at the lower level becoming lighter to give the impression of rising to the heights. In the colors used Trinity church references indicate that the yellow stands for the goodness of God; blue for truth and constancy; red for divine love; black for humility; and white for purity.⁶³

On both the east and west walls of the nave are oak leaf borders leading to a crusader's cross and shield with a silver Star of Bethlehem. The oak leaf pattern shape is found throughout the church. As stated in the 1955 Sixtieth Anniversary history "An oak leaf border is found around the walls leading into a crusader's cross and shield into which is placed the Star of Bethlehem. The oak leaf symbolizes strength and shaped into a cross means in faith one gains strength."⁶⁴ The cross and shield images are centered between each bank of triple art glass windows.

⁶⁰ 1895-1955, Sixtieth Anniversary, Trinity Evangelical Lutheran Church, Russellville, Missouri, November 13, A.D. 1955, page 5.

⁶¹ The Icon, History, Symbolism and Meaning, A Monastic Journal, Winter 2003, Vol. 16, No. 2. Author Anonymous.

⁶² 1895-1955, Sixtieth Anniversary, Trinity Evangelical Lutheran Church, Russellville, Missouri, November 13, A.D. 1955, page 7.

⁶³ Ibid., page 7

⁶⁴ 1895-1955, Sixtieth Anniversary, Trinity Evangelical Lutheran Church, Russellville, Missouri, November 13, A.D. 1955, page 7.

National Register of Historic Places
Continuation Sheet

Section number 8 Page 20

Trinity Lutheran Church Historic District
Name of Property
Cole County, Missouri
County and State
Rural Church Architecture of Missouri, c. 1819 to c. 1945
Name of multiple listing (if applicable)

The base of the walls are painted a darker hue at the lower levels. The hue becomes lighter as one continues to the apex of the walls. At the apex the pattern of oak leaf continues with various symbols of faith incorporated in a smaller version of the shields depicted between the larger art glass windows. On the East wall from the entry to the nave to the chancel arch those symbols are: Alpha symbolizing the beginning; Omega symbolizing the end; Cross symbolizing redemption; and Baptismal font symbolizing baptism. In similar fashion, on the west wall the symbols are IHS, a Christogram coming from the first three letters of the Greek name of Jesus. In Latin the J and I are indistinguishable and the C and S are sometimes interchangeable. Also depicted are the Circle symbolizing eternity; triangle symbolizing the Trinity; and the square symbolizing earthly life. Each symbol is centered within the shield shape as depicted on the side walls of the nave. On either side of these shields with symbol is again the messianic rose depiction. On the walls throughout the nave to the chancel arch the cluster of grapes are incorporated into the oak and messianic rose design. Grapes are known to symbolize the wine used in the Eucharist and are seen as positive as the wine derives from grapes which represent abundance and faith. In words attributed to Photios Kontoglou, a renowned iconographer, "Icons raise the soul and mind of the believer..."⁶⁵ The iconography depicted at Trinity Lutheran is in a schematic way by means of geometric forms; rectangles, ovals, and triangles, demonstrating a heavenly order. This scheme may be seen throughout the church. In church tradition dating from the time of the Byzantine Empire iconography was seen through these various forms in mosaics and wall paintings especially. It is a tradition of sacred and liturgical art whose function is essentially spiritual.

Architect

Based on biographical information Ben H. Linhardt was born in Osage County, Missouri on September 15, 1879. He attended country schools of the county and later went to business college. He began training as a carpenter at 16, but also worked as a store clerk. He had no formal architectural training. He put out his shingle as a building contractor in 1904 and organized the B.H. Linhardt Lumber and Construction Company in 1908. His career in the building trades apparently ended in 1918 when he was elected as the Cole County Recorder. He served from 1923 to 1933 as postmaster in Jefferson City. He later sold insurance and worked as an agent for a real estate investment firm in Jefferson City.⁶⁶ Linhardt died in 1941.

Builder (Church)

Oliver E. Sprouse was a well-known builder, also sometimes named architect, in central Missouri. He was superintendent of construction for the Sanitarium in California, Missouri, and designed and built many brick buildings in that town. He was especially versed in church construction and was involved with the Presbyterian Church and parsonage, Christian Church,

⁶⁵ "The History and Symbolism of Iconography," Monastery Icons, Westchester, Ohio, 2019.

⁶⁶ "Biographical Sketches of Early Cole County Residents." Cole County Historical Society and Museum website. www.colecountymuseum.org/biographical-sketches-of-early-resi.

National Register of Historic Places
Continuation Sheet

Section number 8 Page 21

Trinity Lutheran Church Historic District
Name of Property
Cole County, Missouri
County and State
Rural Church Architecture of Missouri, c. 1819 to c. 1945
Name of multiple listing (if applicable)

Catholic Church and parsonage, and the Baptist Church in California. He gained experience working for bricklayers Stevenson and Stevenson in California, and often worked with Ben Inman, who was also involved in the Trinity Lutheran Church construction.⁶⁷

Conclusion

Not unlike the subtype statewide, the twin-tower type is likely the least common in Cole County. There are only two known examples in the county, both associated with Lutheran congregations. Both are good examples of the type with Trinity Lutheran representing a Romanesque Revival iteration, and St. Paul's, in the town of Lohman, a Gothic Revival style. By itself, the church meets the registration requirement outlined in the MPDF as a significant local example of the type. The associated resources, however, make Trinity Lutheran stand out as an increasingly rare example of a rural church complex.

⁶⁷ "Sanitarium Opening and Booster Edition." *Moniteau County Herald*, California, Mo." January 21, 1926.

National Register of Historic Places
Continuation Sheet

Section number 9 Page 22

Trinity Lutheran Church Historic District
Name of Property
Cole County, Missouri
County and State
Rural Church Architecture of Missouri, c. 1819 to c. 1945
Name of multiple listing (if applicable)

Bibliography

1895-1955, Sixtieth Anniversary, Trinity Evangelical Lutheran Church, Russellville, Missouri, November 13, A.D. 1955.

100th Anniversary, Trinity Evangelical Lutheran Church, Russellville, MO, 1895-1995, B-W Graphics, Inc., Versailles, Missouri, 1995.

Agreement of May 11, 1911, George Eggers and Lutheran Congregation of Russellville, Mo. to erect a Lutheran Parsonage on Lots No. 12 and 13, Schubert's Addition, Village of Russellville, Missouri.

Agreement of 25 October, 1911, between O.E. Sprouse and Ben Inman Contractors and Committee of the second part, M. Schubert, A. Ott, and Louis Schneider.

Articles of Incorporation and Pro Forma Decree, Evangelical Lutheran Trinity Congregation, June 17, 1914.

"Biographical Sketches of Early Cole County Residents." Cole County Historical Society and Museum website. www.colecountyhistoricalmuseum.org/biographicall-sketches-of-early-resi.

Blueprints, Church: For the Evangelical Lutheran Congregation Russellville, Missouri, B. H. Linhardt, Architect, 1911.

Blueprints, Church: Evangelical Lutheran Congregation Russellville, Missouri, note of O.E. Sprouse. California, MO, October 28, 1911.

"Cole County Churches," Cole County Historical Society and Museum website, <https://www.colecountyhistoricalmuseum.org/churches>. Accessed August 18, 2019.

General Warranty Deed, Trustees of Michael Schubert Estate to William Schmoeger, Frank Ott, Julius Buchta trustees of Russellville Evangelical Dreinegskeit Geminde Church for the sum of one dollar, December 5, 1939.

General Warranty Deed, September 12, 1896, Franz Erhart to M. Schubert and John Buchta for the German Evangelical Lutheran Church.

General Warranty Deed, April 27, 1939, C. S. and Estella Glover to Evangelical Lutheran Congregation of Russellville, Missouri.

General Warranty Deed, January 24, 1907, George J. Eggers to Russellville Evangelical Lutheran Dreinegskeit Geminde Church.

General Warranty Deed, January 24, 1907, M. Schubert to Russellville Evangelical Lutheran Dreinegskeit Geminde Church.

National Register of Historic Places
Continuation Sheet

Section number 9 Page 23

Trinity Lutheran Church Historic District
Name of Property
Cole County, Missouri
County and State
Rural Church Architecture of Missouri, c. 1819 to c. 1945
Name of multiple listing (if applicable)

General Warranty Deed, January 24, 1907, George and Katie Schneider, Louis and Katie Schneider to Russellville Evangelical Lutheran Dreinegskeit Geminde Church.

Golden Jubilee, 1895-1945, Trinity Evangelical Lutheran Church, Russellville, Missouri, November 11, 1945.

"The Hinners Organ Story." Robert E. Coleberd, Jr., *The American Organ*, September, 1960.

The History and Symbolism of Iconography, Monastery Icons, Westchester Ohio, 2019.

The Icon, History, Symbolism and Meaning. "A Monastic Journal," Winter, 2003, Vol. 16, No. 2, Author Anonymous.

Memorandum of Agreement, October 13, 1930, A. Hinners, Hinners Organ Co. and O. Rossbach, A. Rossbach and Mrs. M. Schubert, Details of Construction.

Minutes of the Annual Meeting of the Congregation, January 4, 1948.

Minutes of the Annual Meeting of the Congregation, January 9, 1949.

Minutes of the Annual Meeting of the Congregation, January 11, 1953.

Minutes of the Semi-Annual Meeting of the Congregation, July 3, 1955.

Minutes of the Annual Meeting of the Congregation, January 13, 1957.

Minutes of the Annual Meeting of the Congregation, January 9, 1983.

Patterson, Tiffany "Rural Church Architecture of Missouri, c. 1819 to c. 1945." National Register of Historic Places Multiple Property Documentation Form, 2011.

Russellville Weekly Rustler, weekly newspaper published, Russellville, Missouri.

St. Paul's Lutheran Church website, <https://www.stpaulslutheranlohman.org/10-2/>. Accessed October 6, 2019.

"Sanitarium Opening and Booster Edition." *Moniteau County Herald*, California, Mo." January 21, 1926.

Specifications of Material and Labor to be Used in the Erection of a Parsonage for the Evangelical Lutheran congregation, Russellville, 1911, Ben H. Linhardt, Architect, Jefferson City, Mo.

National Register of Historic Places
Continuation Sheet

Section number 9 Page 24

Trinity Lutheran Church Historic District
Name of Property
Cole County, Missouri
County and State
Rural Church Architecture of Missouri, c. 1819 to c. 1945
Name of multiple listing (if applicable)

Specifications of the Material and Work Necessary in the Erection and Completion of the Church for the Evangelical Lutheran Congregation, Russellville, Missouri, 1911, Architect Ben H. Linhardt, Jefferson City, Mo.

Trinity Evangelical Lutheran Church, Records, 1895-1960, Chronik. Notes of Pastor J. Paul Franke, Notes of Conrad Schaff. (translated from the German)

United States Bureau of the Census, United States Census, 1900.

United States Bureau of the Census, United States Census, 1910.

National Register of Historic Places
Continuation Sheet

Section number 10 Page 25

Trinity Lutheran Church Historic District
Name of Property
Cole County, Missouri
County and State
Rural Church Architecture of Missouri, c. 1819 to c. 1945
Name of multiple listing (if applicable)

Historic Boundary Description

4.23 acre plot consisting of Lots 9-15 and also beg. SW Corner Lot 12 Schuberts 1st Addition to Russellville, Missouri, located in Section 3, Township 43, Range 14.

Boundary Justification

The property includes all lands historically associated with the historic church complex.

National Register of Historic Places
Continuation Sheet

Section number 10 Page 26

Trinity Lutheran Church Historic District
Name of Property
Cole County, Missouri
County and State
Rural Church Architecture of Missouri, c. 1819 to c. 1945
Name of multiple listing (if applicable)

Figure 1: Exterior photo Angle Map, (See Figure 7 for interior photos. See Figure 11 for District Map) Not to scale. Top of map is north.

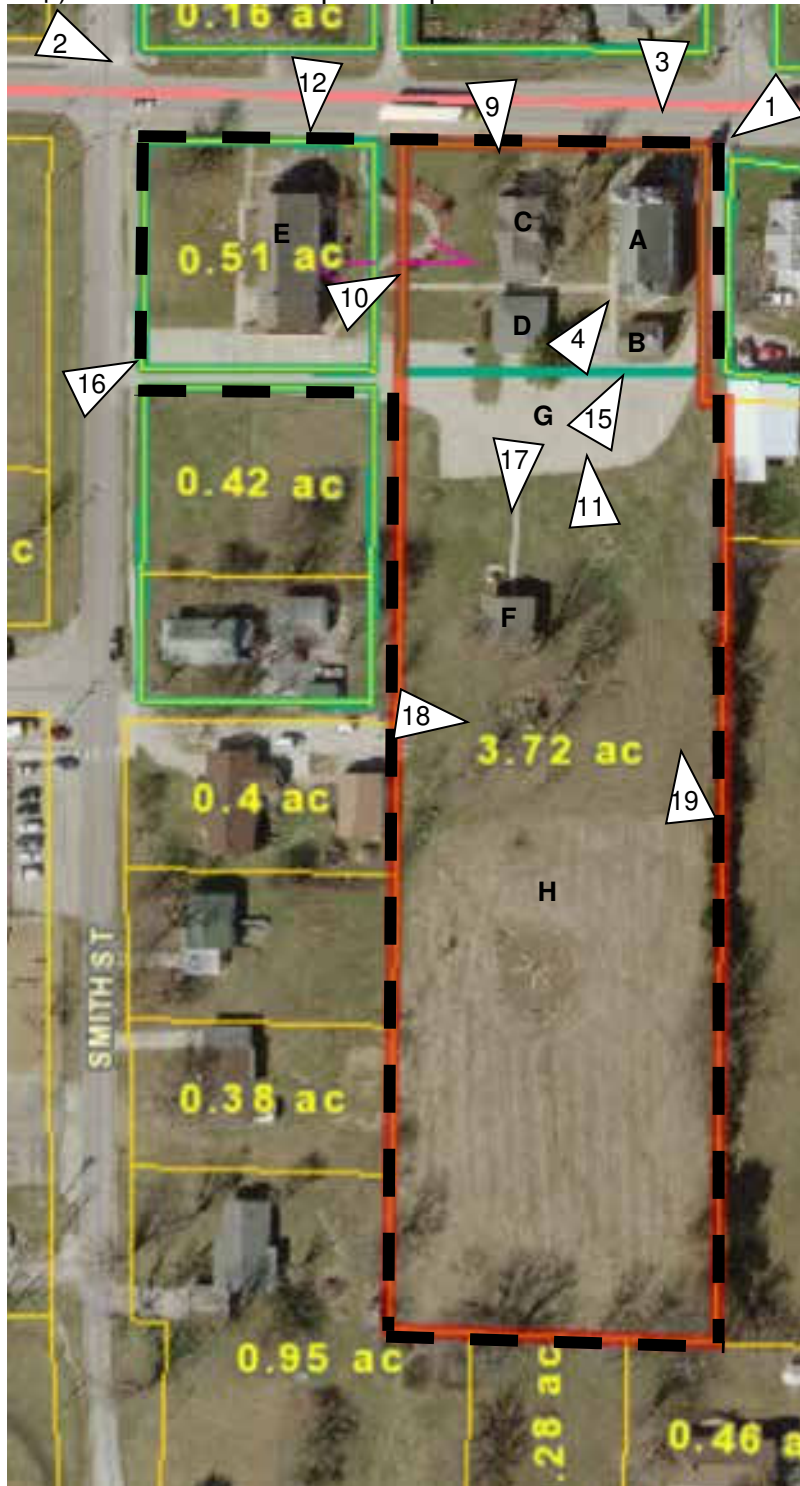

District Map Legend

- Boundary
- △ Exterior photo angles

A. Trinity Lutheran Church
B. School
C. Parsonage
D. Garage
E. Parish Hall
F. Pavilion
G. Parking Lot
H. Greenspace

Note: See figure 7 for interior church photos 5-8.

National Register of Historic Places
Continuation Sheet

Section number Figures Page 27

Trinity Lutheran Church Historic District
Name of Property
Cole County, Missouri
County and State
Rural Church Architecture of Missouri, c. 1819 to c. 1945
Name of multiple listing (if applicable)

Figure 2: Plat Map of Russellville, Mo. From *Standard Atlas of Cole County, Missouri*. Chicago: Geo. A. Ogle & Co., 1914. Star denotes approximate location of the historic district.

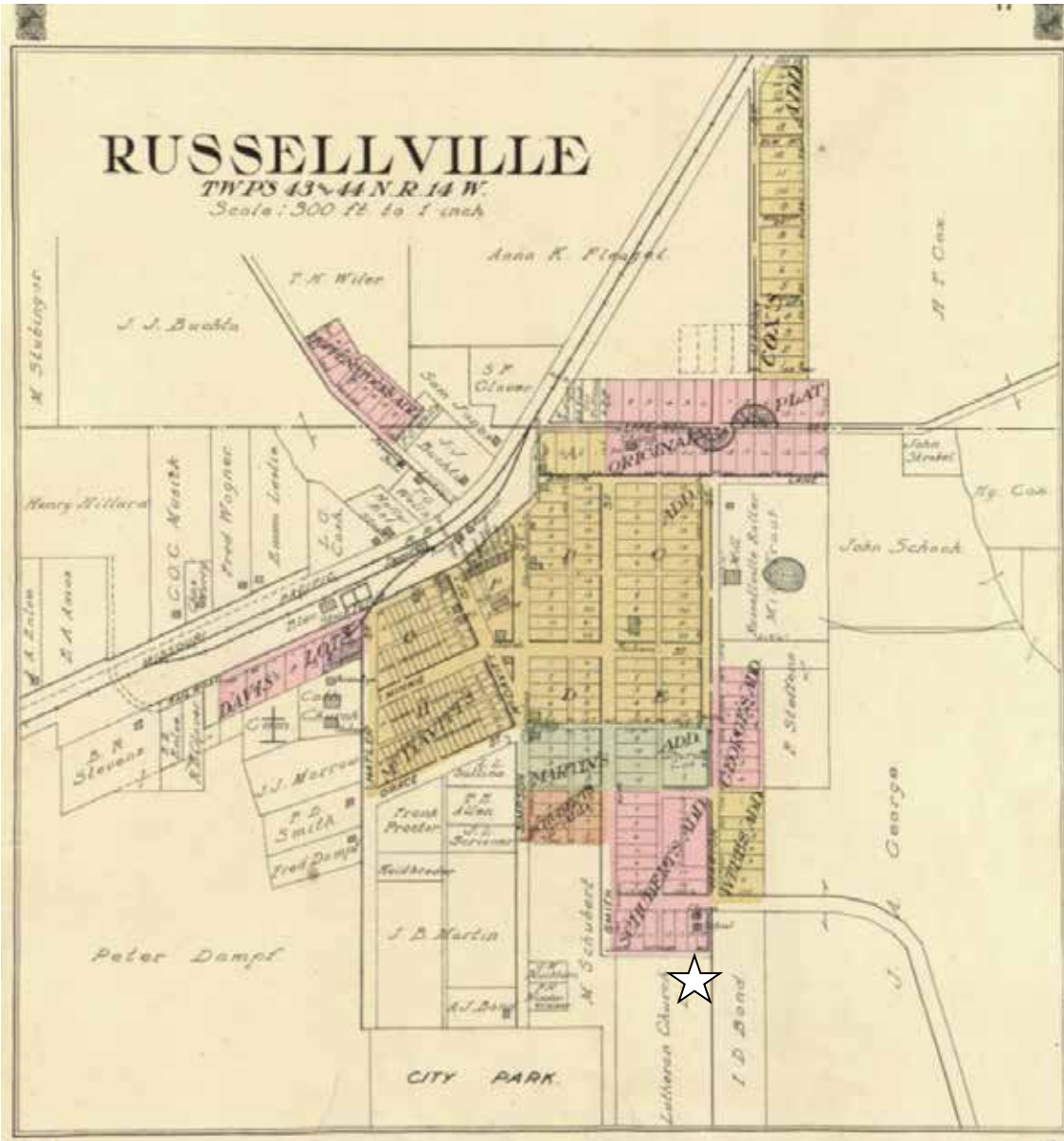

National Register of Historic Places
Continuation Sheet

Section number Figures Page 28

Trinity Lutheran Church Historic District

Name of Property

Cole County, Missouri

County and State

Rural Church Architecture of Missouri, c. 1819 to c. 1945

Name of multiple listing (if applicable)

Figure 3: Early Route C, Russellville, looking west with church in background, c. 1935



National Register of Historic Places
Continuation Sheet

Section number Figures Page 29

Trinity Lutheran Church Historic District

Name of Property

Cole County, Missouri

County and State

Rural Church Architecture of Missouri, c. 1819 to c. 1945

Name of multiple listing (if applicable)

Figure 4: Church under construction, 1911

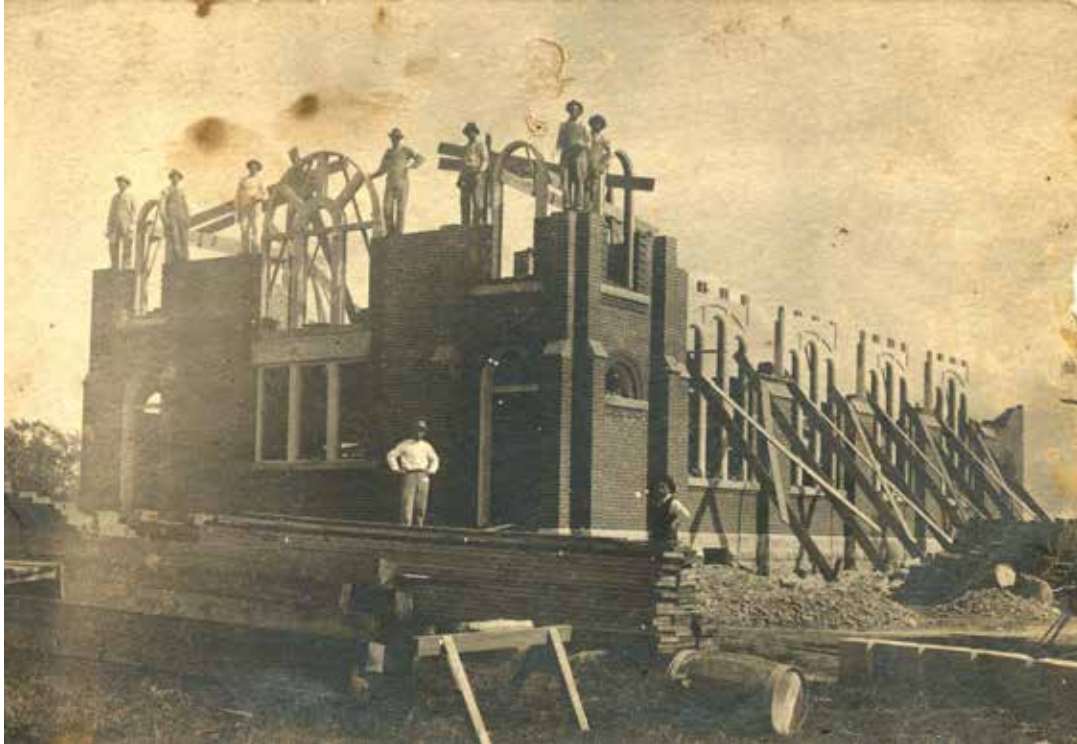

National Register of Historic Places
Continuation Sheet

Section number Figures Page 30

Trinity Lutheran Church Historic District

Name of Property

Cole County, Missouri

County and State

Rural Church Architecture of Missouri, c. 1819 to c. 1945

Name of multiple listing (if applicable)

Figure 5: Church Dedication, 1912



Figure 6: Children Outside School, c. 1925



National Register of Historic Places
Continuation Sheet

Section number Figures Page 31

Trinity Lutheran Church Historic District
Name of Property
Cole County, Missouri
County and State
Rural Church Architecture of Missouri, c. 1819 to c. 1945
Name of multiple listing (if applicable)

Figure 7: Current Floor Plan of Trinity Lutheran Church with photo number arrows

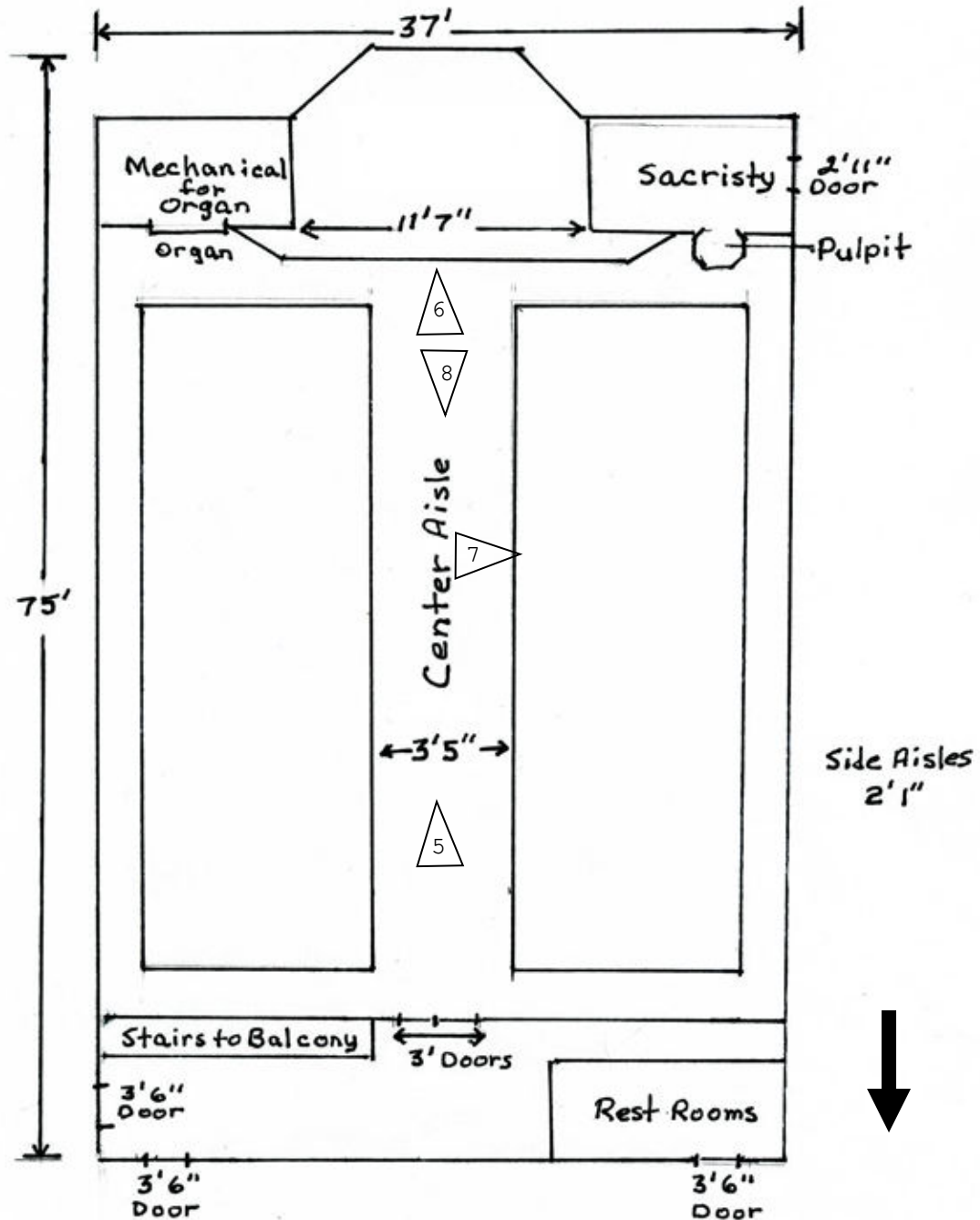

National Register of Historic Places
Continuation Sheet

Section number Figures Page 32

Trinity Lutheran Church Historic District
Name of Property
Cole County, Missouri
County and State
Rural Church Architecture of Missouri, c. 1819 to c. 1945
Name of multiple listing (if applicable)

Figure 8: Current Floor Plan, first floor, Parsonage

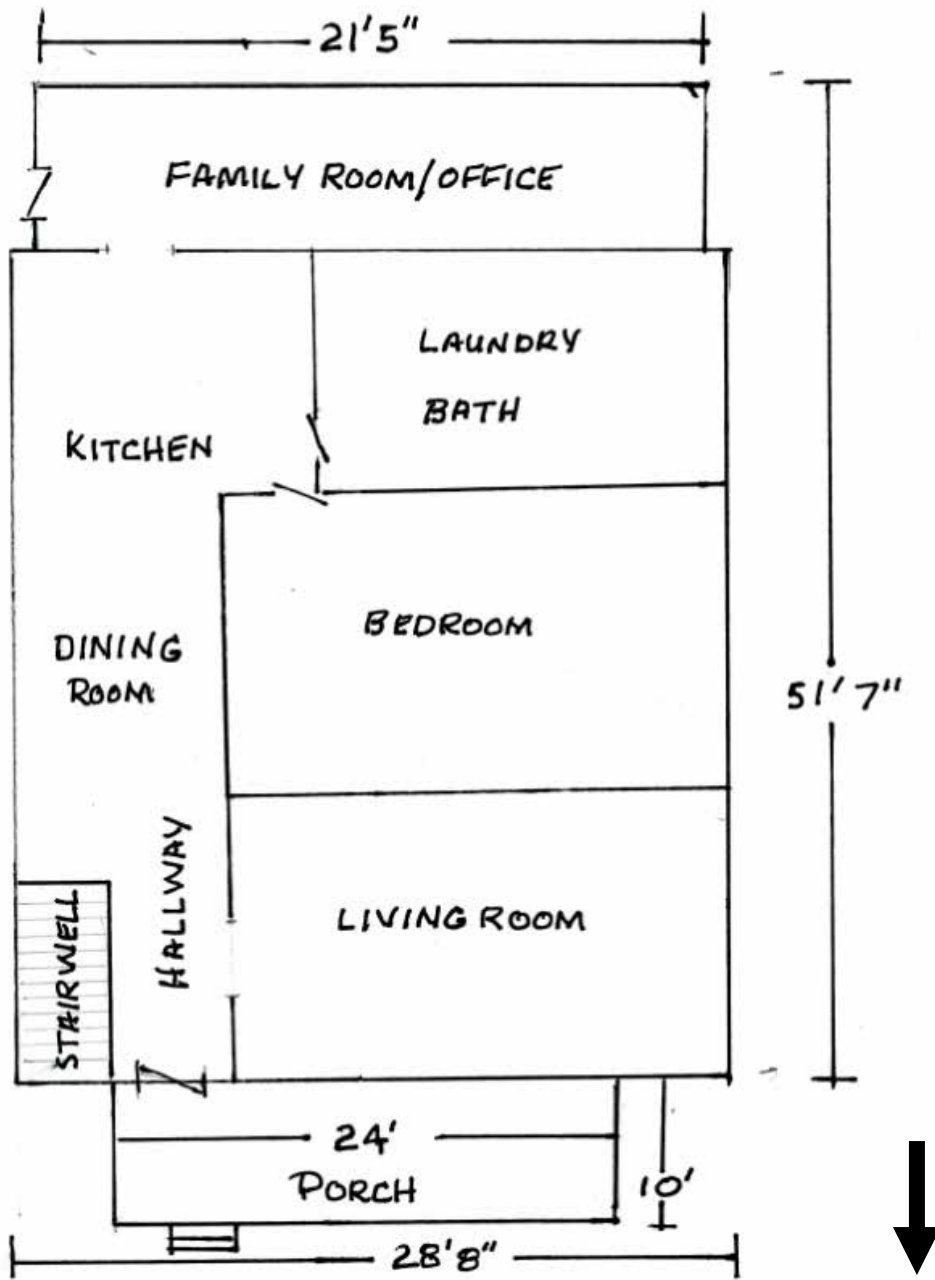

National Register of Historic Places
Continuation Sheet

Section number Figures Page 33

Trinity Lutheran Church Historic District
Name of Property
Cole County, Missouri
County and State
Rural Church Architecture of Missouri, c. 1819 to c. 1945
Name of multiple listing (if applicable)

Figure 9: Current Floor Plan, Parish Hall

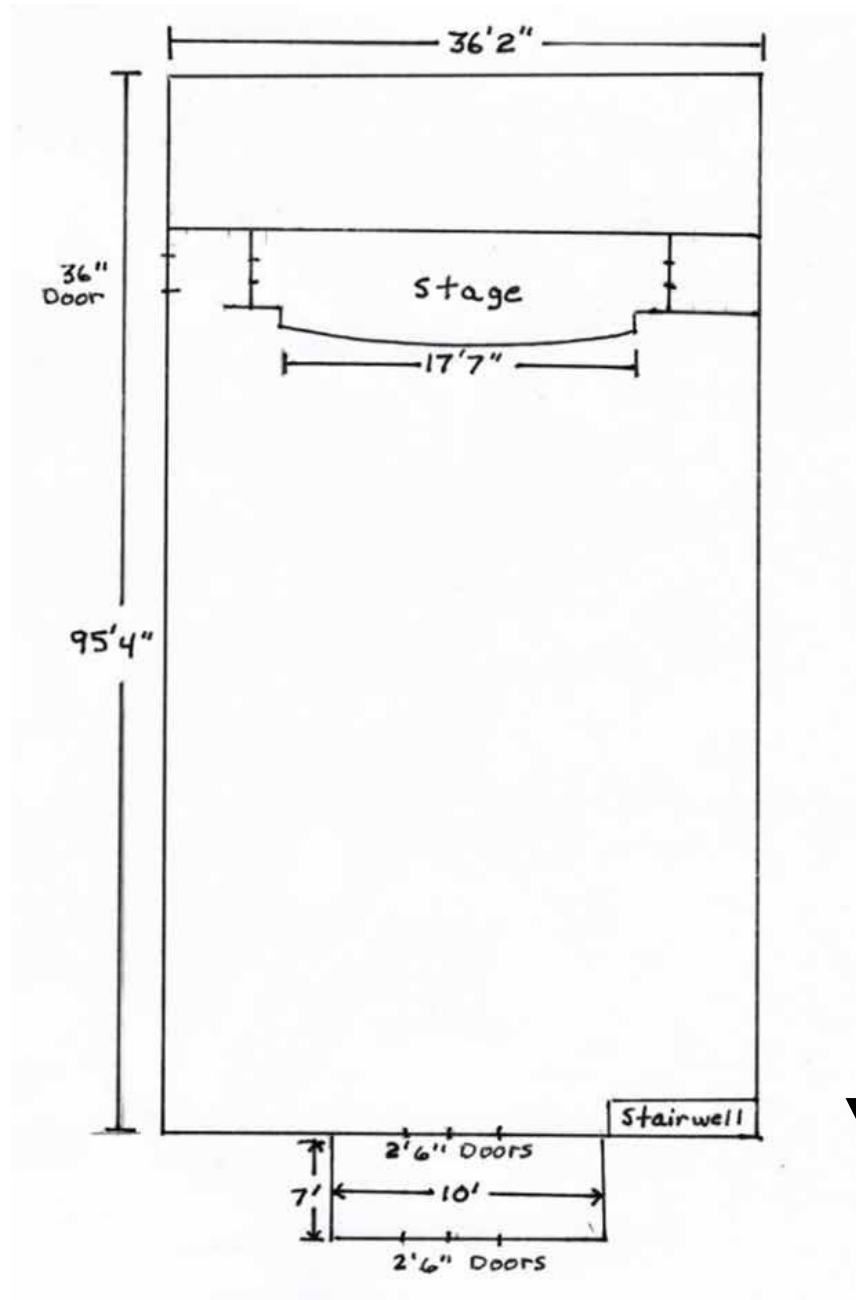

National Register of Historic Places
Continuation Sheet

Section number Figures Page 34

Trinity Lutheran Church Historic District
Name of Property
Cole County, Missouri
County and State
Rural Church Architecture of Missouri, c. 1819 to c. 1945
Name of multiple listing (if applicable)

Figure 10: Site Map. Lat/Long coordinates at red marker: 38.50859 -92.438010
Not to scale. Image from Google Maps.

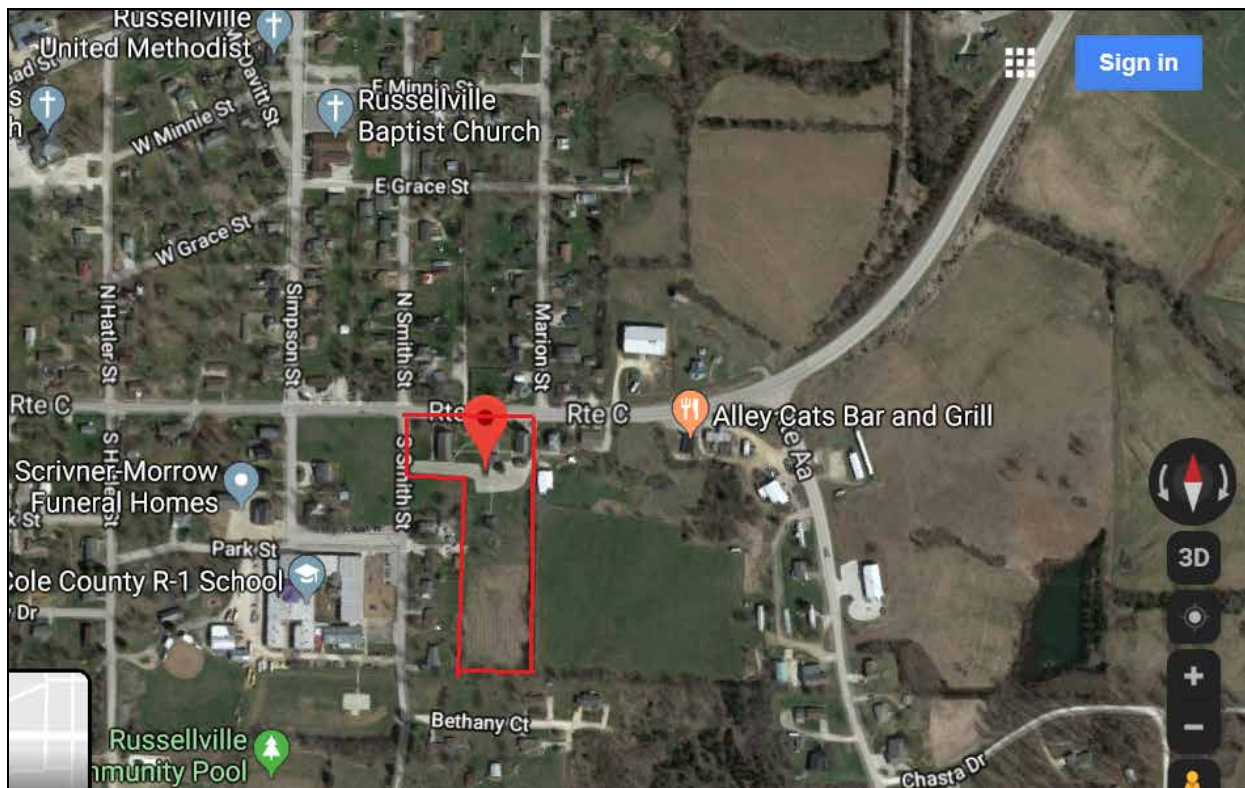

National Register of Historic Places
Continuation Sheet

Section number Figures Page 35

Trinity Lutheran Church Historic District
Name of Property
Cole County, Missouri
County and State
Rural Church Architecture of Missouri, c. 1819 to c. 1945
Name of multiple listing (if applicable)

Figure 11: District Map

Not to Scale. Image from Google Maps. Red marker = Contributing; Aqua marker = Non-contributing

- | | |
|----------------------------|-----------------------------------|
| A: Trinity Lutheran Church | E: Parish Hall |
| B: School | F: N/C Pavilion |
| C: Parsonage | G: N/C Parking Lot |
| D: N/C Garage | H: Greenspace/Field ⁶⁸ |

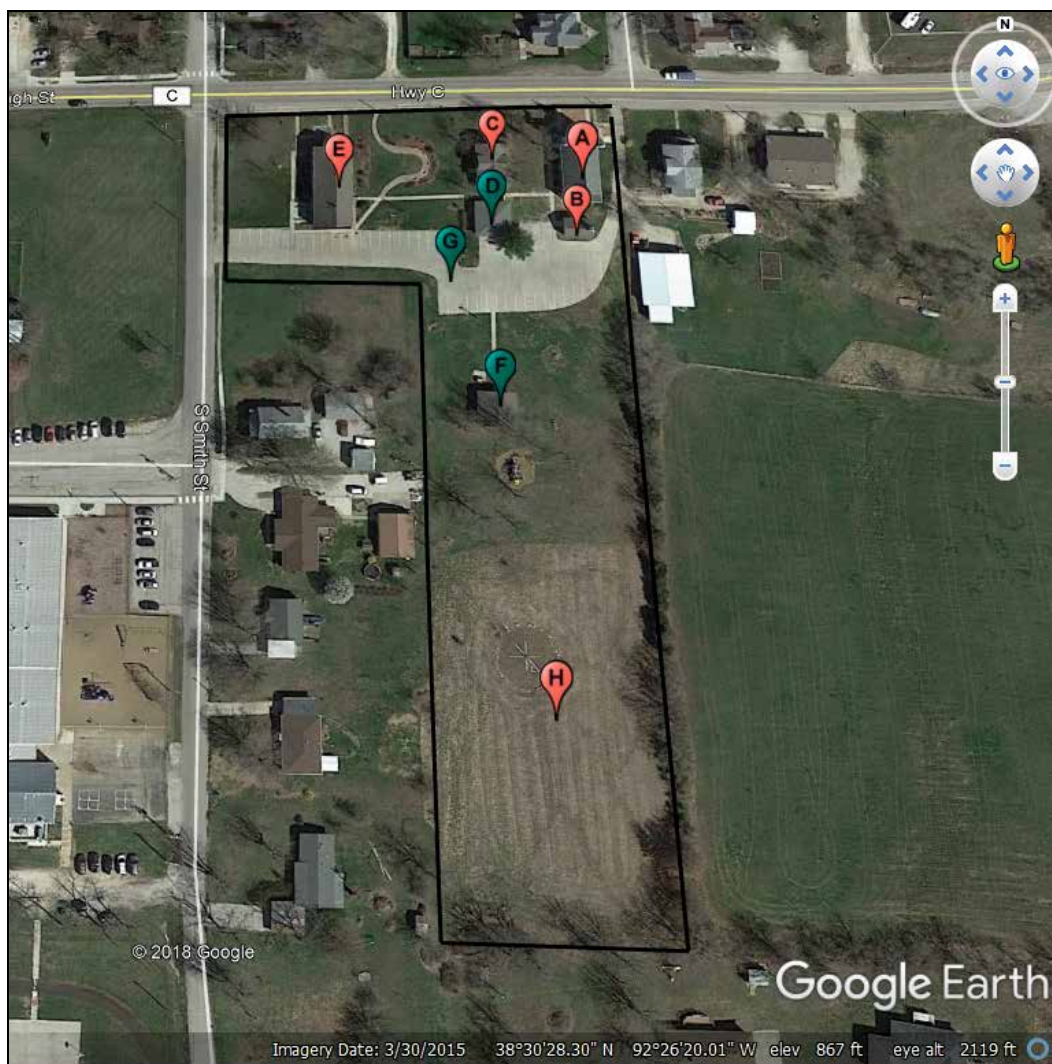

⁶⁸ The circular feature above marker "H" originally served as a prayer/peace garden surrounded by a circular stone wall with stone pathways leading to the center. Completed in 2010, it is not currently maintained or utilized, being replaced by the current garden located between the Parish Hall and Parsonage.

National Register of Historic Places
Continuation Sheet

Section number Figures Page 36

Trinity Lutheran Church Historic District

Name of Property

Cole County, Missouri

County and State

Rural Church Architecture of Missouri, c. 1819 to c. 1945

Name of multiple listing (if applicable)

Figure 12: St. Paul's Lutheran Church, Lohman, Missouri

Image from St. Paul's Lutheran Church website, <https://www.stpaulslutheranlohman.org/10-2/>, accessed October 6, 2019





St. Luke's Episcopal Church

St. Luke's Episcopal Church
WELCOME
Worship services every 1st and 3rd
Sundays 10:00 AM & 11:00 AM
WEDNESDAY 7:00 PM



FIRST BAPTIST CHURCH
WELLSVILLE, OHIO
1884

101
233



EV. LUTH. CHURCH









14TH SUN. AFTER

PENTECOST

865

656

184

✠ HOLY ✠ HOLY ✠ HOLY ✠









JCT
AA











OFFICE





ADULTS
PROHIBITED

NO ALCOHOL
OR DRUGS





