

From Rosin Preservation (6/22/15):

The final spreadsheet for the Boardinghouse Historic District Survey includes changes to forms for “National Register Eligible” (Box 20) and “Area(s) of Significance” (Box 14). We also unchecked “National Register Status” in the “For SHPO Use” section. The evaluations of the resources in Box 20 are based on potential National Register eligibility. The boundaries for the National Register eligibility include most properties within the local Boardinghouse Historic District boundaries. There are no additional properties that would be added to a potential National Register Historic District. A group of resources west of Linden Avenue in the northwest corner of the local district was excluded because the majority of the resources are new construction.

Below is a narrative of the criteria that were used to determine contributing/ non-contributing status.

SURVEY METHODOLOGY

STATUS JUSTIFICATION

Rosin Preservation staff evaluated the status of each building based on the integrity of four primary factors- form, cladding, windows and porches. Together, these three features express the time and period of a building’s construction, and communicate its significance in association with the Boardinghouse neighborhood. If a building retains two out of three of these elements, it would be contributing to a potential historic district. If all three of these elements have been substantially altered, the building would be non-contributing to a potential historic district.

It is likely that most of the buildings originally had wood siding with stucco or brick cladding on some buildings. Only a handful retains the original wood siding today. On nearly forty percent of the resources, asbestos siding replaced the wood siding at an early, unknown date. This siding type has since become historic in its own right. Some houses have non-historic vinyl, aluminum or fiberboard siding. A resource retains integrity of exterior cladding if it has historic stucco, brick, wood siding or asbestos siding.

The vast majority of resources retain their original wood windows. Most have a one-over-one sash configuration. On some resources, select windows have been replaced with non-historic vinyl or aluminum sashes; on others, all of the windows have been replaced. A resource retains integrity of window materials if all historic windows or historic windows on the primary elevation are extant.

Most of the resources retain their integrity of the original porch form. If a resource does not retain its original porch form, this does not necessarily compromise its integrity when the history of the neighborhood is taken into account. The survey area went into decline following the economic decline of the springs, causing many of the resources to fall into disrepair. As exterior features exposed to the elements, periods of neglect had a more significant impact on the condition of porches. Some were enclosed, many had replacement supports, railings or decks, and still others were removed. On some resources, these changes have become historic in their own right. A resource does not retain integrity of porch form if it has been removed. A resource retains integrity of porch form if it has been repaired or replaced with materials and design of their time and place.

BOUNDARY JUSTIFICATION

The boundaries for the survey closely follow the boundaries from the 1994 survey. Parcels along Foley Street were not re-surveyed because the resources have been demolished and would thus be non-contributing to a potential historic district. Properties along North Francis Street were included in this survey because they appear to contributing to a potential historic district. Rosin Preservation wished to obtain a better understanding of these resources through the survey.

From SHPO Staff (7/23/15):

Any staff comments made in the "SHPO USE" section of the survey form relates to a potential National Register district but may not be pertinent when considering local designation.

Please note the survey map corresponds to the survey forms as created by the preparer. It does not reflect any SHPO comments made to the forms.

The survey was conducted for the purposes of creating the accompanying Design Guidelines for the City of Excelsior Springs. As such, it serves as the survey report for this project.

Boarding House District Design Guidelines

A Guide for the Rehabilitation, Restoration and Preservation of Residential and Commercial Properties within the Historic Boarding House Neighborhood

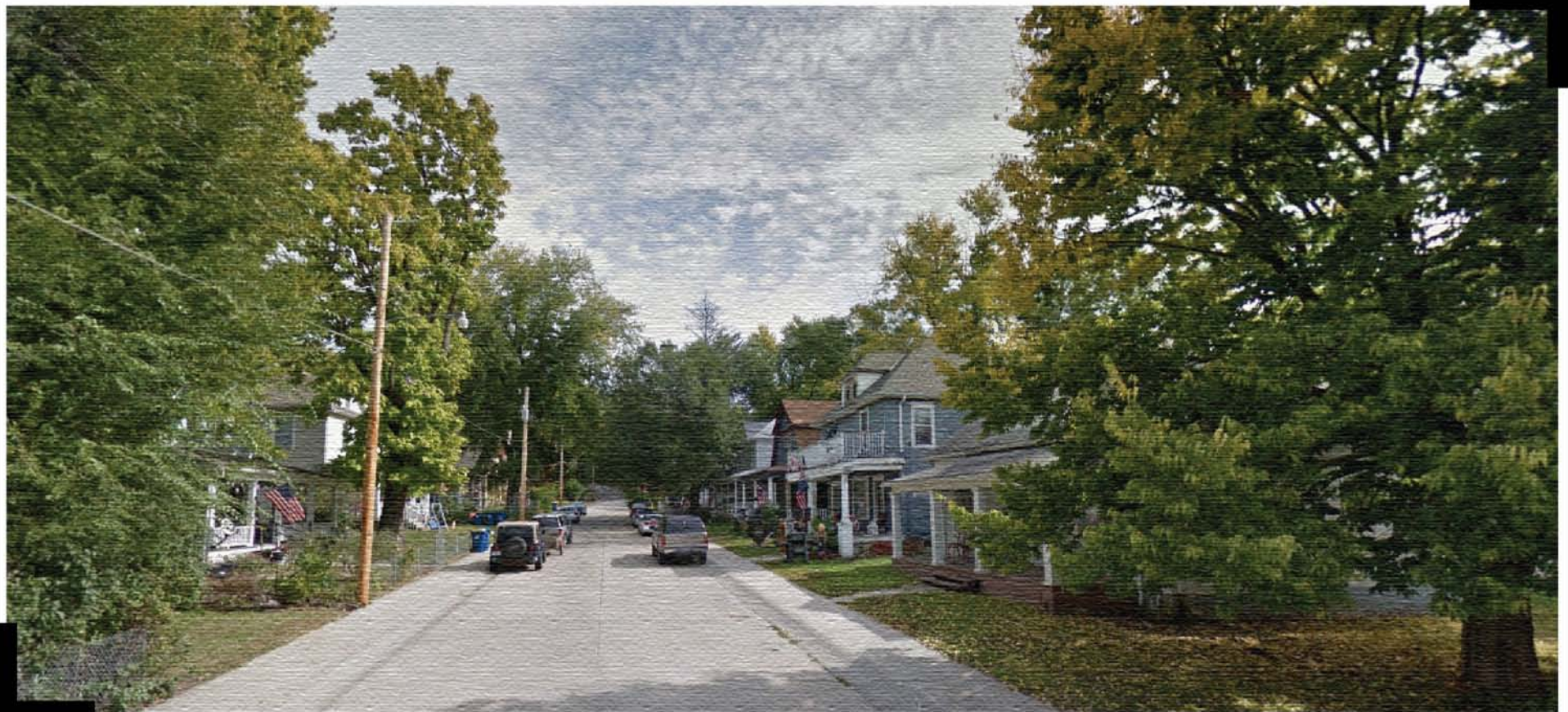

June 1, 2015

Excelsior Springs Historic Preservation Commission
www.eshpc.org



TABLE OF CONTENTS



1	Introduction	1-10	
2	Local Historic District	11-18	
	<ul style="list-style-type: none">• Boarding House Historic District• Contributing vs. Non-Contributing Properties• Frequently Asked Questions (FAQ)• Historic District Maps		
3	Application Process & Frequently Asked Questions	19-38	
	<ul style="list-style-type: none">• Certificate of Appropriateness (COA)• Frequently Asked Questions (FAQ)• Certificate of Appropriateness Approval Matrix• Sample Application		
4	Architectural Styles	39-62	
5	Design Guidelines for Rehabilitation	63-108	
	<ul style="list-style-type: none">• Illustrated Guide to the Secretary of the Interior’s Standards for Rehabilitation• Masonry• Siding and Trim• Substitute Materials• Removal of Synthetic Siding• Stucco• Concrete• Roofs, Gutters and Downspouts• Doors and Windows• Porches, Decks and Balconies		
	<ul style="list-style-type: none">• Architectural Metals• Mechanical Equipment• Awnings• Lighting• Retaining Walls• Fences and Railings• Alleyways or Rear Facades• Landscaping• Sustainability		
6	Design Guidelines for New Construction	109-118	
	<ul style="list-style-type: none">• Designing a Building within a Historic District• Elements of Design• Outbuildings• Additions		
7	Demolition	119-124	
	<ul style="list-style-type: none">• Mothballing Treatment• Demolition by Neglect and Corrective Measures		
8	Appendices	125-150	
	<ul style="list-style-type: none">• Appendix A: Bibliography and Resources• Appendix B: Glossary• Appendix C: National Register vs. Local Register Matrix• Appendix D: Grid Paper		



First Edition

BOARDING HOUSE DISTRICT DESIGN GUIDELINES

MAYOR

Ambrose Buckman

MAYOR PRO-TEM

Brad Eales

CITY COUNCILMEN

Brent McElwee

Sonya Morgan

Sharon Powell

CITY MANAGER

David Haugland

HISTORIC PRESERVATION COMMISSION

Craig Bohnert—Chair

Marilyn Gerdes

Pat Grass

Stephany Hughes

Lance Lamb

Molly McGovern

Brandee Soria

CITY PLANNING DEPARTMENT

Larry Murry, Planning and Zoning and Inspections Department Director

PREPARED BY

Rosin Preservation, LLC and Susan Richards Johnson & Associates, Inc.

This publication is partially funded by a grant from the Missouri Department of Natural Resources, State Historic Preservation Office and the National Park Service, U.S. Department of the Interior. Grant awards do not imply an endorsement of contents by the grantor. This program receives Federal financial assistance for identification and protection of historic properties. Under Title VI of the Civil Rights Act of 1964, Section 504 of the Rehabilitation Act of 1973, and the Age Discrimination Act of 1975, as amended, the U.S. Department of the Interior prohibits discrimination on the basis of race, color, national origin, disability or age in its federally assisted programs. If you believe you have been discriminated against in any program activity, or facility as described above, or if you desire further information, please write to: Office of Equal Opportunity, National Park Service, 1849 C Street, N. W., Washington, D.C. 20240.

Additional funding provided by the City of Excelsior Springs, Missouri. Adopted by Mayor and Council of Excelsior Springs, Missouri on [TBD].

All rights reserved. Copyright © 2015. No part of this book may be reproduced, stored in a retrieval system, or transmitted in any form or by any means without prior consent of the publisher.



Boarding House Historic District Survey and Design Guidelines

The City of Excelsior Springs, Missouri (City) has a strong commitment to historic preservation and providing protection for designated historic resources that lie within its boundaries. This commitment was formalized by establishing the Historic Preservation Commission by ordinance in 1978. The Missouri Department of Natural Resources' State Historic Preservation Office (SHPO) designated Excelsior Springs as a Certified Local Government in 1991.

Recognizing the need to ensure that the evaluation and protection of historic resources accurately reflects the specific built environment in each historic district, the City contracted Rosin Preservation, LLC, and Susan Richards Johnson and Associates, Inc., to update the *survey* of buildings in the Boarding House Historic District (District) and prepare *design guidelines* that address the specific conditions and materials found within the District.

The survey findings and documentation (including official written Architectural/Historic Inventory Forms and photographic documentation) provide the basis for many preservation decisions, including developing design guidelines to inform decisions made regarding the improvement of properties in the local historic district, identifying buildings or districts eligible for the National Register of Historic Places, and evaluating the impacts of government actions on historic resources. Survey results also help the City better understand and protect these historic resources by raising awareness among the public of the significance of the City's building inventory and by educating and boosting interest in private investment in the rehabilitation of historic buildings for new uses.

Intent of Design Guidelines

The intent of the Design Guidelines is to serve business owners, homeowners, and developers in their pursuit of rehabilitation of historic buildings and new construction within the Boarding House Historic District. These guidelines are not intended to inhibit change, new construction, or new architectural styles, as long as such changes complement the existing buildings and streetscapes. The purpose is several-fold:

1. To support the principles set forth in *The Secretary of the Interior's Standards for the Treatment of Historic Properties*.
2. To promote and preserve the historic and cultural integrity of the district.
3. To provide advisory recommendations of the best way to reinforce and protect the unique historic pattern and character of the district.
4. To ensure visual, physical and functional compatibility of the exterior, publicly-visible portion of the buildings, landscape, and context. These guidelines do not affect how interior space is utilized or designed.
5. To encourage new quality design and construction within the district to be compatible with its historic context, and to serve as a tool for designers. The ultimate goal is to promote creative and sensitive new designs while preventing designs that would weaken the integrity of the district through inappropriate or non-compatible designs that do not relate to the historic context, regardless of their quality.
6. To protect the value of public and private investment, which might otherwise be threatened by the undesirable consequences of poorly managed growth.



Historic Building Survey Methodology

The first step in developing appropriate design guidelines requires an understanding of the area to which the guidelines will be applied. Rosin Preservation, LLC performed an on-site field survey of each property, building, structure, and object located within the established boundaries of the Boarding House Historic District. The survey information was compiled in a Microsoft Access database using a template based on the Missouri SHPO Historic Resources Survey Form. The database fields record each building's physical features (e.g., plan, materials, architectural style and/or property type, outbuildings, etc.) as well as historical information (e.g., date of construction, original and current function). The historical information was collected from the 1994 survey of the District. When linked with digital records from past and future surveys, this database will enhance the understanding of historic resources in the Boarding House District of



Excelsior Springs. The database can also use the City's parcel identification information system to link to Geographic Information System (GIS) and mapping software.

Hard copies of the survey forms are available at the City offices.



Left: 201 South Francis, 2014. Above: 434 Benton Avenue, 2014.

Use of Survey Information

The information gathered in the survey is used to identify historic features and characteristics of the neighborhood and the individual resources. This data informs the topics that will be addressed in the design guidelines. The survey also identifies *contributing* and *non-contributing* properties. The contributing/non-contributing status of a property determines the level of review required for various changes to the property.

Excelsior Springs Historic Preservation Ordinance

In 2005, Excelsior Springs adopted the revised Historic Preservation Ordinance (Ordinance Section 402, a copy of the Preservation Ordinance can be found at the Mid-Continent Library). The purpose of the ordinance is to promote the educational, cultural, economic and general welfare of the City of Excelsior Springs by:

1. Providing a mechanism to identify and preserve the distinctive historic and architectural characteristics of Excelsior Springs which represent elements of the city's cultural, social, economic, political and architectural history.
2. Fostering civic pride in the beauty and noble accomplishments of the past as represented in Excelsior Springs Landmarks and Historic Districts.
3. Conserving and improving the value of property designated as landmarks or within historic districts.
4. Protecting and enhancing the attractiveness of the City to home buyers, tourists, visitors and shoppers, and thereby supporting and promoting business, commerce, industry, and providing economic benefit to the City.
5. Fostering and encouraging preservation, restoration and rehabilitation of structures, areas and neighborhoods, thereby preventing future urban blight (Ord. No. 90-4-4 & 1, 4-16-89).



Top: 314 East Excelsior, 2014. Bottom: 215 South Francis, 2014.

Historic Preservation Commission

The role of the Preservation Commission is to assist the City in the administration of the ordinance. The Commission consists of seven members, residents of Excelsior Springs appointed by the Mayor and approved by the City Council.

Meeting Times:

Second Wednesday of each month at 4:00 PM in the Hall of Waters City Council Chambers.

A special meeting may also be called for the fourth Wednesday of the month if deemed necessary by the Chairperson and City Staff. The Historic Preservation Commission reviews *Certificates of Appropriateness* applications for the following:

- New construction and additions to existing buildings.
- Alterations, removals or exterior repairs.
- Demolition of buildings.
- Relocation of buildings.
- New or replacement signs and awnings.

Refer to Chapter 3 for more information about Certificate of Appropriateness: what it is, what it covers, and how to navigate the process.

Commissioners typically include a registered architect or engineer, a person having at least five years experience in construction, a person having at least five years experience in real estate, a historian living in the community at least twenty years, and three persons chosen from the citizens at large. The term of each member is three years. Additional Information regarding Excelsior Springs' Preservation Ordinance and Preservation Commission may be found at www.eshpc.org.

Members of the public are encouraged to contact the City Planning and Zoning Director to discuss questions or concerns about preservation, historic districts and local or National historic designation. The Planning Department is able to provide information about the designation process, answer questions about the Certificate of Appropriateness application process and assist with technical resources for performing work on designated buildings.

It is always recommended to consult with the City's Planning and Zoning Staff prior to beginning the application process or starting exterior work. The Planning Director and Commission are experienced in working with owners to help them meet their practical needs while preserving the architectural and historic character of the City.

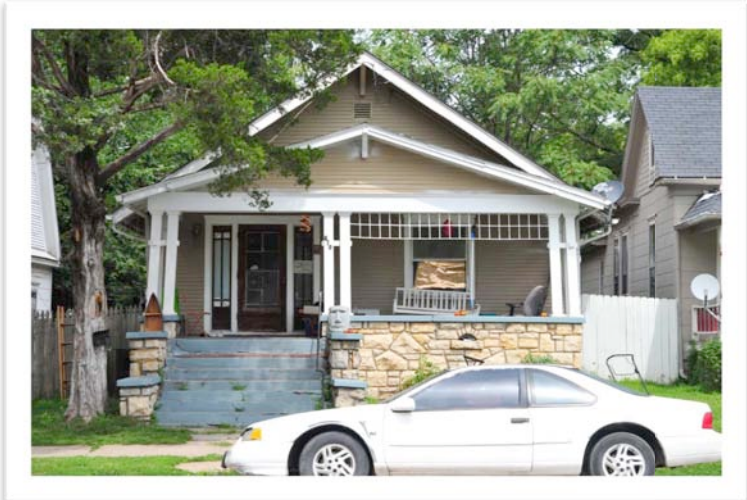

Top: 438 East Excelsior, 2014. Bottom: 510 Isley, 2014.

Additional Resources

For the most current, up-to-date information, refer to the following resources which are available for download from the City's Historic Preservation website: www.eshpc.org including (but not limited to):

- Certificate of Appropriateness (COA) Application
- COA Approval Matrix
- Hall of Waters Historic District Design Guidelines
- Historic Preservation and Revitalization Plan
- Historic District Maps
- Benefits of Living in a Historic District/State Rehabilitation Tax Credit Program Information
- Links to technical references for listing a property on the National Register of Historic Places, the Secretary of the Interior's Standards for the Treatment of Historic Properties, technical preservation briefs, and additional preservation related website links

If you would like more information, call or write the Planning and Zoning Director at City Hall, 201 E. Broadway, Excelsior Springs, MO 64024. Phone: (816) 630-0756 or through the City's website: www.eshpc.org

Boarding House Historic District

The Boarding House Historic District was established in July 2010 based upon recommendations developed from the 2006 Comprehensive Historic Preservation Plan. Surveys of the historic resources in Excelsior Springs have been an ongoing endeavor beginning with the first surveys completed in 1991-1993. In 2014, Rosin Preservation, LLC completed the re-survey of the Boarding House Historic District. The goal of this survey was to identify and evaluate historic resources as part of on-going efforts to maintain a vital residential neighborhood and to move toward change in a positive manner. To achieve this goal, it was necessary first to understand the assets that contribute to the survey area's unique physical and cultural character; and to develop goals, policies and initiatives to assist the City and the community in the evaluation and protection of its remaining cultural resources.

The Boarding House Historic District remains an important residential neighborhood that reflects the early history of Excelsior Springs as it became a regional health and recreational destination. The buildings that document this sequence of development tell a unique and important story. They define the residential history of the community and provide tangible reminders of the past that create a unique sense of place. The area retains much of its historic character as it evolved to accommodate large numbers of temporary residents visiting this important regional destination. As economic forces continue to guide choices property owners make regarding the built environment, change provides the opportunity to strengthen and enrich the visual character of the neighborhood and to enhance the quality of life already appreciated by residents.

Excelsior Springs has a unique history of providing long- and short-term accommodations for visitors partaking of its healing mineral waters. Preservation of historic structures within the Boarding House Historic District will protect the vital history and unique sense of place of Excelsior Springs. Preservation of the residential historic context promotes community pride, increases property values, helps stabilize the district, promotes economic growth and encourages investment.

In total, the Boarding House Historic District includes:

- 114 properties total
- 69 contributing properties
- 31 non-contributing properties
- 14 vacant lots/parking lots
- 24 properties were known hotels, boarding houses or apartment buildings
- 7 mineral water springs and associated structures
- 73 single dwellings
- 1 religious facility and 1 library



339 East Broadway (Carnegie Library and Saratoga Springs Pavilion), 2014.

Contributing vs. Non-Contributing Properties

All properties within historic districts are classified as either “Contributing” or “Non-Contributing” to a district, in this case the Boarding House Historic District. If a property is individually listed and located outside of a district, this classification does not apply.

A Contributing property is defined as a building (house) or structure (garages, sheds, barns, well springs, etc.) that adds to the historic significance of a district or neighborhood through its location, design, setting, materials, workmanship, architectural style, feeling, association and history. A Contributing property is one that still reflects much of how it looked historically.

A Non-Contributing property is defined as a building or structure that lacks historic significance due to when it was built (age), which typically means that the building was built much later than the historic buildings in the district or neighborhood or is less than 50 years old. Buildings may be classified as Non-Contributing even if they are historic if they show a significant loss of original design or architectural features. Additionally, buildings may be Non-Contributing if the property has been altered to the point that its original design is obscured and removing the alterations would be technically and/or economically infeasible without damage to historic materials or features.

The City of Excelsior Springs Planning and Zoning Director, along with the Historic Preservation Commission, determine if a property is Contributing

or Non-Contributing to a district. The historic resources survey associated with the development of these guidelines, completed in 2014, generated official Missouri Department of Natural Resources Architectural/Historic Inventory Forms for each property in the Boarding House Historic District. The forms include a recommendation of Contributing vs. Non-Contributing status. A map coded to identify Contributing and Non-Contributing properties is included on Page 16.

Proposed alterations to properties that are classified as historic and Contributing to a district are typically reviewed more stringently than those that are Non-Contributing. The reason is because any exterior improvement could potentially impact the overall historic appearance and character of a building or structure in a district. As a result, it is always recommended to consult with the City’s Planning and Zoning Director prior to beginning the application process. A description of the review process is included in Chapter 3.



Example of a Contributing Property in the Boarding House Historic District.
526 Isley Boulevard, 2014.

Contributing vs. Non-Contributing (continued)

The survey provided an evaluation of the status of each building based on the integrity of four primary factors: form, cladding, windows and porches. Together, these four features express the time and period of a building's construction and communicate its significance in association with the Boarding House neighborhood. If a building retains its historic form and one of the three remaining elements, it is considered *Contributing* to the local historic district. If all of these elements have been substantially altered, the building is considered *Non-Contributing* to the local historic district.

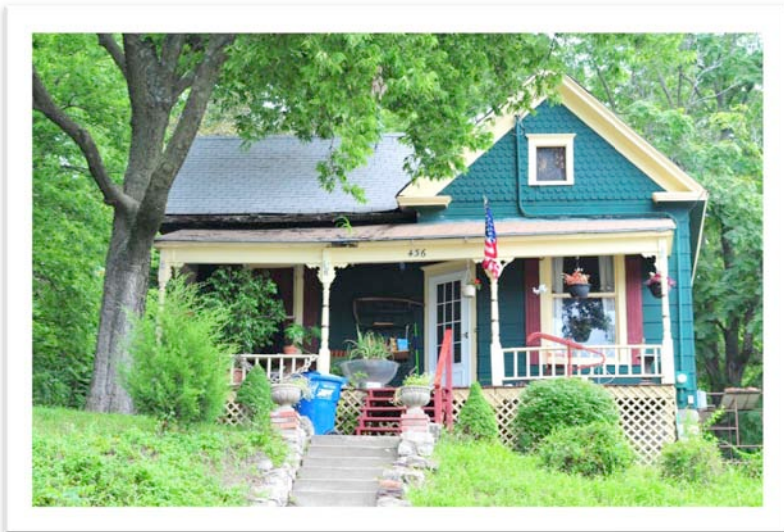

Example of a Contributing Property in the Boarding House Historic District.
All exterior character-defining features and elements are intact.
526 Isley Boulevard, 2014.

Form

The form is the overall shape, footprint and height of a building. Most resources retain their historic form, meaning they have their original roof shape, number of stories, and few, if any, additions. The location and size of additions are factors in determining their impact on the form. Additions to the rear or side do not necessarily render a building non-contributing. Form is important in communicating the era in which a building was constructed.

Siding

It is likely that most of the buildings originally had wood siding with stucco or brick cladding on some buildings. Only a handful retain their original wood siding today. On nearly forty percent of the resources, asbestos siding replaced the wood siding at an early, unknown date. This siding type has since become historic in its own right. Some houses have non-historic vinyl, aluminum, or fiberboard siding. A resource retains integrity of exterior cladding if it has historic stucco, brick, wood siding or asbestos siding.

Windows

The vast majority of resources retain their original wood windows. Most have a one-over-one sash configuration. On some resources, select windows have been replaced with non-historic vinyl or aluminum sashes; on others, all of the windows have been replaced. A resource retains integrity of window materials if all historic windows or historic windows on the primary elevation are extant.

Porches

Most of the resources retain their integrity of the original porch form. If a resource does not retain its original porch form, this does not necessarily compromise its integrity when the history of the neighborhood is taken into account. The survey area went into decline following the economic decline of the springs, causing many of the resources to fall into disrepair. As exterior features were exposed to the elements, periods of neglect had a more significant impact on the condition of porches than any other feature. Some were enclosed, many had replacement supports, railings or decks, and still others were removed. On some resources, these changes have become historic in their own right. A resource does not retain integrity of porch form if it has been removed. A resource retains integrity of porch form if it has been repaired or replaced with historically appropriate materials and design.



Example of a Non-Contributing Property in the Boarding House Historic District. Exterior siding and windows have been replaced and the exterior historic porches have been removed/altered.
408 East Broadway, 2014.

FAQs: Historic Districts and What Local Historic Landmark Designation Means for Building Owners:

Q: My property has been designated as a local historic landmark or as part of a historic district. What does this mean?

A: When your property has been designated as a historic landmark or as part of a historic district, the City and Historic Preservation Commission officially recognize that your property has historical and cultural value to the City of Excelsior Springs and that your property is an important part of Excelsior Springs' historical and architectural heritage.

To help protect the City's historic properties from inappropriate changes or destruction, the Historic Preservation Commission must approve in advance any alteration, reconstruction, demolition or new construction affecting the designated properties. *Refer to **Chapter 3: Application Process** for additional information.*

Q: What is a historic district?

A: A historic district is an area of the city that has been designated by the City Council because it has a special historical or aesthetic quality, character or charm that creates a distinct "sense of place."

Q: How can I find out if my property is designated?

A: If you do not know whether your property is an individual landmark or located within the boundaries of a historic district, contact the Planning and Zoning Director of the City Planning and Development Department.

Q: How large are historic districts?

A: Historic districts range in size from small groups of historic properties to areas containing hundreds of properties.

Boarding House Historic District Map



Boarding House Historic District Mineral Water Resources

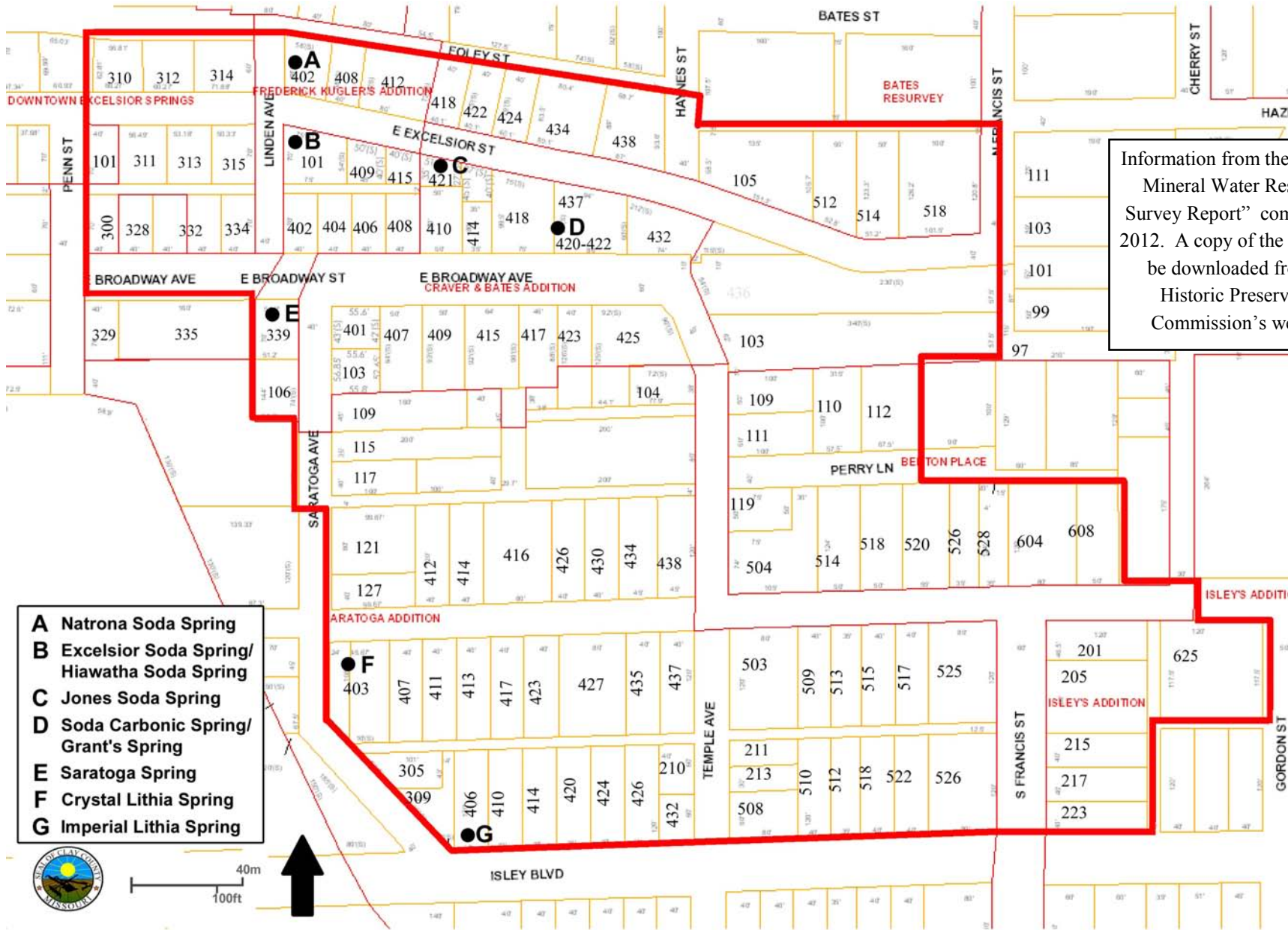

Information from the “Historic Mineral Water Resources Survey Report” completed in 2012. A copy of the report can be downloaded from the Historic Preservation Commission’s website.

- A** Natrona Soda Spring
- B** Excelsior Soda Spring/
Hiawatha Soda Spring
- C** Jones Soda Spring
- D** Soda Carbonic Spring/
Grant’s Spring
- E** Saratoga Spring
- F** Crystal Lithia Spring
- G** Imperial Lithia Spring

3

APPLICATION PROCESS & FAQ

The Application Process

All exterior alterations to locally designated historic properties or properties located within a historic district require review by either the City Planning and Zoning Director and/or the Historic Preservation Commission prior to beginning work. The City Staff and Historic Preservation Commission base their design review decisions on the same set of principles for all properties. Buildings that possess a greater degree of architectural integrity, craftsmanship and historic significance will be taken into consideration when an application for a Certificate of Appropriateness is made. Additionally, alterations that are visible from either a public street or an alley also are taken into consideration during the decision-making process. The design guidelines outlined in Chapters 5, 6 and 7 are applied for all alterations, new construction, demolition and repairs affecting the exterior appearance of a property.



In addition to exterior improvements to houses, exterior garages, outbuildings, landscaping, site retaining walls, fences and driveways also require a Certificate of Appropriateness. 503 Benton Avenue, 2014.



Example of exterior rehabilitation in process. 411 Benton Avenue, 2014.

Note: It is important to remember that ANY exterior changes to your property (alterations, changes to building materials, new construction, demolition, site improvements, etc.) are subject to review by the City Planning and Zoning Director or Historic Preservation Commission *before* the project begins, regardless of whether or not a building permit is required.

Certificate of Appropriateness

A Certificate of Appropriateness (COA) is similar to a building permit, and is required before beginning exterior work in the Boarding House Historic District. A COA is issued by the Historic Preservation Commission and indicates that the proposed change has been reviewed and approved. Once the COA has been obtained, the applicant can apply for a building permit. In cases where a building permit is not required, it is still necessary to acquire a COA before beginning the project.

The Certificate of Appropriateness is only valid for the project it was approved by the Historic Preservation Commission. Any changes to the plans approved by the Commission must be reviewed by the Historic Preservation Commission. Often, City Staff can approve changes, but the Preservation Office must be notified before changes are made.

The fee for applying for a Certificate of Appropriateness is \$25.00 as of 2015 and is subject to change, confirm online or with the City prior to application. Application forms are available from the Planning and Zoning Department by calling 816-630-0756 or by downloading the application at the Excelsior Springs Historic Preservation Commission website. Staff at the Planning and Zoning Department is available to aid in the application process.

<http://www.eshpc.org/index.html>.



Exterior porches are important character defining elements to many properties in the district. Exterior porches and exterior stairs (form, style, location and materials) require a Certificate of Appropriateness. Above: 407 East Broadway, 2014. Below: 503 Benton Avenue, 2014.

Staff Review

Excelsior Springs' Planning and Zoning Director serves as City Staff to the Historic Preservation Commission and makes recommendations to the Commission based on the preservation and zoning ordinances and these design guidelines. In some cases, the Planning Director may be able to issue a Certificate of Appropriateness for items considered "minor works," including:

- In-kind repairs, maintenance and replacement of existing features and architectural details.
- Landscaping, driveways and sidewalks.
- Removal of non-historic materials.
- Renewal of an expired COA without change to the original approval.
- All other changes that do not require a building permit.
- Emergency repairs to abate a hazardous condition.
 - Refer to the attached Certificate of Appropriateness Approval Matrix for a detailed list.

Appeals

Appeals may be filed with the Board of Zoning and Adjustment within thirty (30) days after the Historic Preservation Commission's decision.

Stop Work Order

If a project that requires a Certificate of Appropriateness has been initiated without prior approval, a stop work order may be issued to the owners, occupants, contractors or subcontractors.

If a project fails to comply with any part of the Certificate of Appropriateness that has been issued by the Historic Preservation Commission, a stop work order may be issued, which states the violation and the deadline by which to rectify the violation.

Provisions

Certificates of Appropriateness are effective for a period of twelve (12) months. If applicable, a building permit for the work described in the COA should be applied for after receipt of COA. The Certificate of Appropriateness will expire at the end of twelve (12) months and if the work has not been completed, the applicant will be required to request a new COA.

Certificate of Appropriateness Checklist

- Pre-Application meeting with City Planning and Zoning Director (recommended but not required).
- Application Fee - Checks made payable to 'The City of Excelsior Springs'.
- Current photographs of the existing property.
- Current photographs and/or sketches of the existing property with proposed exterior improvements marked (include materials and color samples for each affected area. To ensure accurate portrayal, color samples should be original, not color photocopies).
- List materials to be used for repair, replacement or new construction (manufacturer's brochures may be included for reference).
- Provide material samples (optional, when available).
- Construction documents and architectural drawings (if work requires a building permit or new construction).
- Engineering report and cost estimates (required for demolition only, but can be submitted with application if available for building permit).
- Submit completed application and fee to:

Community Development, Planning and Zoning Department
City of Excelsior Springs, 201 East Broadway
Excelsior Springs, Missouri 64024
- Attend the Historic Preservation Commission meeting.

FAQs: Certificate of Appropriateness Process

Q: Is my property located in a historic district? If so, how do I know if it is contributing or non-contributing?

A: Refer to the historic district map included in Chapter 2 and to the City’s website for current maps and information. Definitions for contributing and non-contributing properties are included within this chapter. If you need assistance in determining if your property is “contributing” or “non-contributing”, or require additional assistance or consultation, contact the Planning and Zoning Director.

Q: My property is located in a local Historic District. Do I need the Commission’s approval to make changes?

A: Yes, for exterior changes. Every designated structure, whether it is an individual landmark or a property in a historic district, is protected under the Excelsior Springs Historic Preservation Ordinance and is subject to the same review procedures. If you want to perform rehabilitation work, new construction, demolition, alterations to landscape plans or alterations to your property (with the exception of ordinary repairs), you must obtain the Commission’s approval before you begin the work. This approval is called a *Certificate of Appropriateness*.

Q: When making changes to a property designated as a historic landmark or located within a historic district, who needs to apply for a COA from the Preservation Commission?

A: Every property owner within the Boarding House Historic District of Excelsior Springs must apply for a COA from the Historic Preservation Commission when proposing any exterior changes to a property.

Q: What changes to my property require a COA?

A: A COA is required for:

- ANY alteration or exterior change to an existing building, such as the alteration or replacement of doors, windows or roofing.
- Color changes (paint).
- Installations of or modifications to: fences, decks, sidewalks, ramps, driveways and outdoor amenities.
- Demolition of ANY structure, including garages and outbuildings.
- Construction of a new building or addition, including garages and outbuildings.

Q: Are there any types of work that do not require the Commission’s approval?

A: Ordinary and necessary maintenance which does not involve a material change does not require the Commission’s approval. For example, replacing broken window glass or removing painted graffiti would not require approval. Additionally, any interior work in your building does not require approval. Refer to the attached Certificate of Appropriateness Approval Matrix for detailed information regarding what work requires the Commission’s approval. You can also call the Planning and Zoning Director for a consultation about whether approval is needed for work you are considering.

Q: May I demolish a designated building on a historic property?

A: You must apply for a *Certificate of Appropriateness* to demolish a building on a designated property. In reviewing applications for demolition,

the Commission will consider the basis of the designation and whether demolition is necessary based upon the information presented in the application and by the Planning and Zoning Director's Staff Report.

Q: Will historic designation prevent all alterations and new construction?

A: No. Historic designation does not “freeze” a property or an area in time. Alterations, demolition and new construction on vacant lots are allowed; however, the Historic Preservation Commission must review the proposed changes and find them to be appropriate. This helps ensure that the special qualities and character of the historic district or individually designated buildings are not compromised or destroyed.

Q: How and when is the application made?

A: Application for a COA is made to the Historic Preservation Commission in the form of a written request. The written application should be given or mailed to City Staff of the Department of Planning fifteen (15) working days before the regularly scheduled meeting. Meeting time and place is posted on the Excelsior Springs' Historic Preservation Commission website and at the west entrance of the Hall of Waters. If the application is not complete, the applicant will be notified so that all information can be provided by the meeting time.

Applicants, or their representatives, are encouraged to attend the meeting of the Historic Preservation Commission when their application is discussed so they can answer questions. Applicant attendance is required when a special meeting is requested.

For larger projects or projects requiring information from consultants such as architects or contractors, it is preferable to meet with the City Planning

and Zoning Director in the design/planning stage. City Staff can offer advice and suggestions that will facilitate the approval process.

Q: What do I need to include in my written request?

A: For smaller projects such as material changes:

- Indicate types of materials to be used.
- Include a written description or photograph of architectural details, if applicable.
- Provide paint samples, if applicable.
- For signs, give size, style of sign and lettering and location, including clearance height.
- Provide the name, address and phone number of the person who will be completing the project.

Q: What do I need to include in my written request?

A: For new construction or additions, provide plans drawn to scale, including the following:

- Two-dimensional drawings of all four elevations, including accurate roof pitch.
- Site plan showing the exact location of the new or altered construction on existing lot, indicating distances to property lines and other buildings on lot and location of fences, sidewalks, driveways, decks and patios.
- Indicate location of demolition, if applicable.
- Indicate types of materials to be used.
- Provide paint samples, if applicable.
- Include a written description or photograph of architectural details, if applicable.
- If signs are to be part of the new construction, give size, colors, style of sign and lettering and location, including clearance height.
- Provide the name, address and phone number of the person who will be completing the project.

Q: When will I know if my project is approved?

A: Within ten (10) days following the regular Historic Preservation Commission meeting on the second Wednesday of each month, the Planning and Zoning Director will send you a COA or a Letter of Denial. Reasons will be provided in writing.

Q: I own a 1990s building in a historic district. Why does the Historic Preservation Commission review changes to my property?

A: To preserve a historic district's special character, the Commission reviews changes to all buildings within its boundaries. The Commission must review the proposed changes to your property to make sure that the overall design is sensitive to the scale and character of the historic district and that the alterations will not detract from the special qualities of the surrounding properties in the district.

If you apply to the Historic Preservation Commission to make changes to your property, the Commission will take into account the fact that your property is a contemporary (non-contributing) structure. You will not be asked to alter your design to make it look "old-fashioned." If you want to put in new windows, for example, you will not be asked to install multi-paned wooden windows if they did not exist before.

Q: Can the Historic Preservation Commission make me restore my property to the way it looked when it was first built?

A: No. The Commission reviews only changes that the property owner proposes to make.

Q: Will the Historic Preservation Commission make me repair my property?

A: The adopted Excelsior Springs Historic Preservation Ordinance (Ordinance Section 402) and the adopted Maintenance Ordinance (Ordinance Section 235) require that all properties must be kept in good repair and meet the minimum requirements of the Property Maintenance Code and any other regulatory codes. These ordinances and regulatory codes are intended to help prevent properties from becoming unsafe to inhabit and reduce demolition by neglect. They also help maintain property values of a neighborhood and keep vacant or derelict properties from becoming an 'eyesore' or blight a neighborhood. If you are interested in finding out about making repairs to your designated property to meet the minimum maintenance code, you can call the Planning and Zoning Director for advice.

Q: I own a designated property. Should I tell the tenants in my building about the property's historic status?

A: Yes. You should inform each of your tenants that the property is listed on the local historic register and/or is located in a historic district and as such is subject to the provisions of the historic ordinance. The Commission must approve exterior alterations in advance. If a tenant makes exterior alterations without receiving Historic Preservation Commission approval before doing the work, the building owner, as well as the tenant, will be held responsible.

Q: I want to sell my historic property. Must I tell the Historic Preservation Commission?

A: No. Historic designation places no restriction on an owner's right to sell his or her property.

Q: If I sell my property, should I tell the new owner that the property is a historic landmark or is located within a historic district?

A: Yes. It will help the new owner understand the opportunities afforded by the designation and will notify them of the guidelines set forth for any future exterior rehabilitation work.

Q: Are historic buildings owned by not-for-profit organizations subject to the same regulations?

A: Yes. Approvals and permits for work on properties owned by not-for-profit owners are the same as the criteria for work on any other property.

Q: Is being listed on the Local Historic Landmark Register different from being listed in the National Register?

A: Yes. The *National Register of Historic Places* is a list of buildings and sites of local, state or national importance. This program is administered by the National Park Service and the Missouri State Historic Preservation Office (MOSHPO). The National Register has no connection to the Excelsior Springs Historic Preservation Commission, although many properties listed as local historic landmarks are also listed in the National Register. For information regarding the National Register of Historic Places, contact the Missouri State Historic Preservation Office, Department of Natural Resources, P.O. Box 176, Jefferson City, MO 65102-0176; Telephone (573) 751-7858.

Q: What are my options if I am denied a COA?

A: You may submit a revised application, or you may appeal the decision through the Board of Zoning and Adjustment within thirty (30) days after the Historic Preservation Commission's decision.

It is always recommended to consult with the Planning and Zoning Director prior to beginning the application process or starting exterior work. The City Planning and Zoning Director is available to help you with any questions you have about your property, explain the application process, and assist with guidance about appropriate materials or technical advice.

If you would like more information, call or write the Planning and Zoning Director at the Hall of Waters, 201 E. Broadway, Excelsior Springs, MO 64024.

Phone: (816) 630-0756 or through the City's website: www.eshpc.org



Certificate of Appropriateness Approval Matrix



ACTION	CONTRIBUTING			NON-CONTRIBUTING		
	Exempt	Administrative	HPC	No Approval	Administrative	HPC
Additions			x			x
Accessory Outbuildings / Garages (visible and not visible from the street)			x			x
Awnings (new installation)			x			x
Awnings (color change)		x			x	
Decks (visible and not visible from the street)			x		x	
Decorative Shutters		x			x	
Demolitions (partial and all of building or structure)			x		x	
Doors (visible from the street)			x		x	
Doors (not visible from the street)		x			x	
Driveways		x			x	
Equipment (Antennas, Satellite Dishes, Solar Panels, etc..)		x			x	
Exterior Siding, Stucco & Trim Repairs In-Kind	x			x		
Exterior Siding, Stucco & Trim (Replacement with New Materials)			x			x
Fences or Gates & Railings		x			x	
Foundation, repair	x			x		
Fountains (visible from the street)			x			x

ISSUED: 2/20/2015

1 of 3



Certificate of Appropriateness Approval Matrix

ACTION	CONTRIBUTING			NON-CONTRIBUTING		
	Exempt	Administrative	HPC	No Approval	Administrative	HPC
Landscaping (including new materials and mature tree removal visible from the street)		x			x	
Lighting (visible from street)			x		x	
Masonry (repointing minor repairs)	x			x		
Masonry (major rehabilitation and new construction)			x			x
Mechanical Equipment (Exterior A/C condensers, other exterior equipment)		x			x	
New Construction (infill)			x			x
Paint (color change)			x		x	
Pools			x			x
Porches (modifications and new construction)			x			x
Ramps (visible from street)			x			x
Relocation of Building or Structure			x			x
Retaining Walls			x		x	
Roofing, Repair	x			x		
Roofing Replacement In-Kind (color and material), Gutters and Downspouts	x			x		
Roof Replacement (with different materials) Gutters and Downspouts			x			x



Certificate of Appropriateness Approval Matrix



ACTION	CONTRIBUTING			NON-CONTRIBUTING		
	Exempt	Administrative	HPC	No Approval	Administrative	HPC
Screened-in Existing Porches			x		x	
Screened-in Porches, New Construction			x			x
Sidewalks, Repair	x			x		
Sidewalks, New Construction			x			x
Signs/Plaques			x			x
Site Lighting, Repair/Replacement In-Kind	x			x		
Site Lighting, New Installation			x			x
Storm Windows, Replacement In-Kind	x			x		
Storm Windows, New Materials			x			x
Windows, Repair	x			x		
Windows, Replacement In-Kind		x			x	
Windows, New Materials			x			x

Don't forget to fill out all the required information! Be sure to read the instructions on page two. An incomplete application will not be reviewed. If you have questions about if your property is a contributing or non-contributing building, contact the Community Development Department and they will help you!

Community Development Department
Planning & Zoning
Phone: 816-630-0756; Fax: 816-630-9572



APPLICATION FOR CERTIFICATE OF APPROPRIATENESS

Case No. _____
Administrative HPC
(for office use only)

Date: _____
Property Address: _____
Name of Applicant: _____
Name of Owner (if different from Applicant): _____
Applicant's Mailing Address: _____
Telephone No.: _____ (home) _____ (work)
Hall of Waters Historic District, Local Landmark, Other: _____
• If Federal or State permits, licensing, or monies are included in the project, a review by the State Historic Preservation Office (SHPO) may be required in conjunction with city review. If applicable, attach a list of Federal or State permits, licensing or funds involved in the project.
Check all that apply:
 Contributing Non-contributing Commercial Residential In-fill



INSTRUCTIONS FOR COMPLETING AND FILING THE CERTIFICATE OF APPROPRIATENESS (COA) APPLICATION

Applications may be submitted to the Community Development Department, Planning Department located at 201 E. Broadway at any time between the hours of 7:30 A.M. and 4:30 P.M., Monday through Friday. The Historic Preservation Commission will act on the application at the next available meeting. Historic Preservation Commission meetings are held on the second Wednesday of each month at 4:00 P.M. in the Council Chambers, second floor of the Hall of Waters, 201 E. Broadway. A completed application accompanied by a \$25 fee is required to process any application that requires Historic Preservation Commission approval. Please make checks payable to: The City of Excelsior Springs. Please print or type all of the required information to ensure that the application is promptly expedited. Please return application to:

Planning & Zoning Director
City of Excelsior Springs
201 East Broadway
Excelsior Springs, Missouri 64024

It is strongly recommended that the applicant arrange a meeting with the Planning & Zoning Director prior to submitting and application for Certificate of Appropriateness. City staff can be reached at 816-630-0756. It is strongly recommended that the property owner or authorized agent attend the Historic Preservation Commission meeting when the COA is reviewed.

The applicant agrees that all work performed in conjunction with a Certificate of Appropriateness will be in conformance with the Design Guidelines and *The Secretary of the Interior's Standards/Guidelines* if not otherwise specified in approval of the Certificate. Applicants are encouraged to refer to the Historic Preservation Design Guidelines developed for the Hall of Waters Historic District located on the Historic Preservation Commission's web site at www.eshpc.org. All work will be fully and completely described in this application and no changes or additions will be made without approval of the Historic Preservation Commission or by the granting of a new Certificate of Appropriateness.

INSTRUCTIONS:

1. All applications must include a written PROPERTY DESCRIPTION. In the space provided or on additional sheets, describe the nature and extent of the proposed work. Include a listing of materials and dimensions when applicable. Provide sufficient detail to allow the Historic Preservation Commission to make an informed decision regarding appropriateness. Scaled drawings, or drawings stamped and signed by a licensed engineer or architect in the state of Missouri are not necessarily required unless a building permit is required for the proposed project. However, all other drawings must accurately

It is encouraged to take current photos of the property and mark on them what you are proposing to do. It an easy and effective way to get your point across.

**Certificate of Appropriateness
Scope of Work for 426 Concourse Avenue
Excelsior Springs, MO**

We do hereby propose to do the following renovations and restoration to the exterior of property at 426 Concourse Avenue in Excelsior Springs, Mo, herein referred to as Building A and Building B. This property is located within the Hall of Waters Historic District and is of significant historical value to the city of Excelsior Springs, MO., being the site of the first jail in Excelsior Springs and the long time residence of Bill and Edna Payne. Bill served as Police Chief for Excelsior Springs from 1925 through 1953.

The scope of work is to include:

Building A

- Remove deteriorated chimney chase from basement through roof and repair decking on roof as needed. (New heating system and water heaters will not require flue. Vent for new heating system will be located out of sightline from street.)

*refer to pictures #1 and #2



- Remove existing shingles, repair decking as needed and re-roof with architectural 40 yr. shingles. (color sample to be provided)
*refer to picture #3

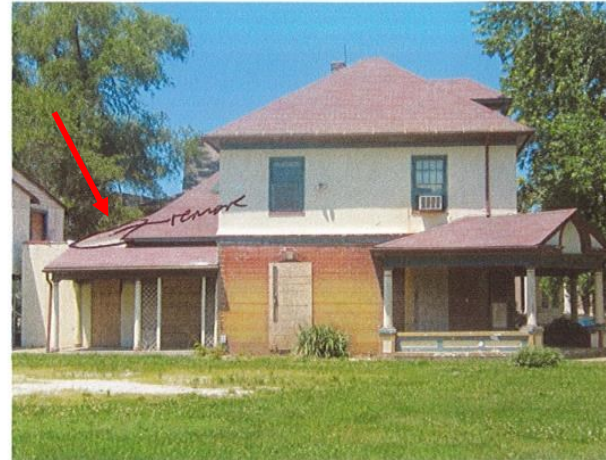

- Remove roofing addition at rear of Building A to restore original roofline on add-on. (This add-on is believed to be the jail structure added by Bill Payne after original construction of home. The roofline has been compromised by adding multiple pitches in an attempt to shed water.) Make repairs to framing of roof as needed and re-roof.

*refer to pictures #4 & 5



Be thorough and describe in detail all proposed work, including work to buildings and site.

- Remove old guttering. Make repairs to fascia and soffit as needed. Make repairs to windows as needed. Paint sash, trim, fascia and soffit with colors of period. Paint and install new guttering to match trim color.
*refer to color samples
- Repair stucco surfaces as needed and paint with color of period. Tuck point brick as needed and rebuild back wall of Building A add-on.
*refer to color samples and pictures #3 & 6



- Make repairs to porch columns as needed. Paint columns and porch structures with colors of period.
*refer to color samples
- Install aluminum storm windows and paint to match trim color.
*refer to color samples
- Make repairs to concrete on patios, porches and sidewalks as needed.

Building B

- Remove add-on structure to Building B and replace with appropriate porch structure full width on building, four feet in depth with stairway on South side of building. Railing will be constructed to include balustrade to period. (Structure needs to be removed to restore integrity to Building A. Current add-on structure of building B is using part of brick structure on Building A for support. The new porch deck will facilitate entry into existing door on Building B for access into Suite #3 of B & B.
*refer to picture #7 and drawing A



- Remove rear covered porch structure of Building B to restore integrity to original roofline. Replace with porch deck to match period with balustrade to match same on front of Building B.





The picture at left gives you an idea how I plan to use the colors. The paint color of this house is antique pewter, but I plan on using the medium brown.

The two front storm doors are made of aluminum, popular in the 70's, and in very poor condition—beyond repair. I'd like to replace them with Larson storm doors, with full view & retractable screen, as shown at right. Both interior doors will be refinished & are very nice.

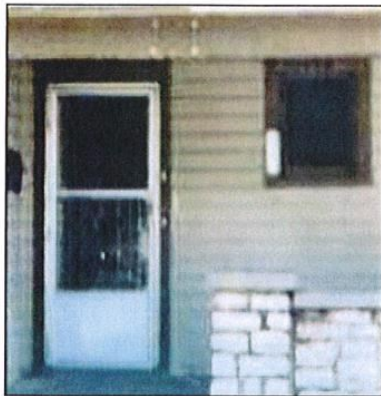

There is a small window on the front porch, shown in the picture at left. It currently has a blue plastic window in it, but it probably contained a stained glass window when built. I'd like to replace it with a stained glass window 20" x 30". I haven't found one yet, but will either purchase an old one at an antique mall, or have one built. Samples below show what I might use. Estimated Cost of \$500.



After repairing the exterior of it, I'd like to paint it in a slightly different color, that does maintain earth tones. For the house I propose a medium brown, called creamed coffee, with most of the trim painted in a light tan, called classic crème, with some of the trim offset in a copper color called two cents. These three colors are shown below.

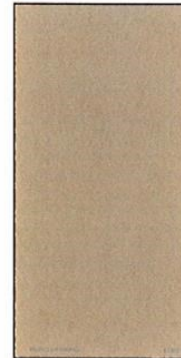

Creamed Coffee

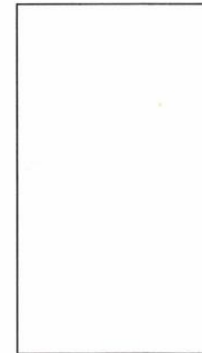

Classic Creme

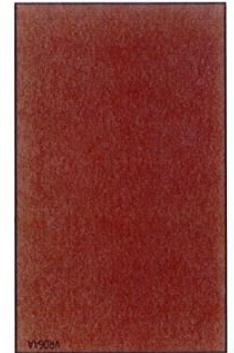

Two Cents



Be Creative! Go to the hardware store and pick up paint color sample cards and attach them to your application.

Including sample inspirational images and/or manufacturer's product brochures of what you are proposing to do is a great way to help the Historic Preservation Commission review your project.

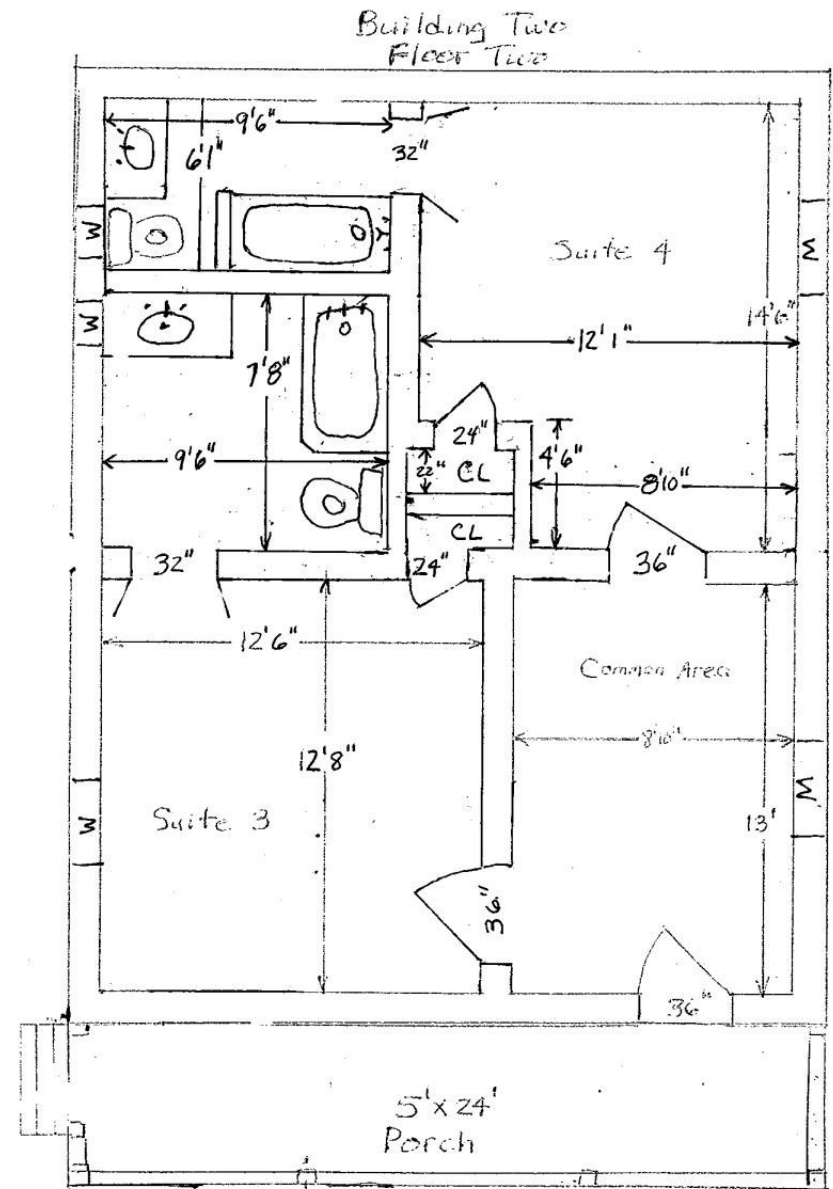
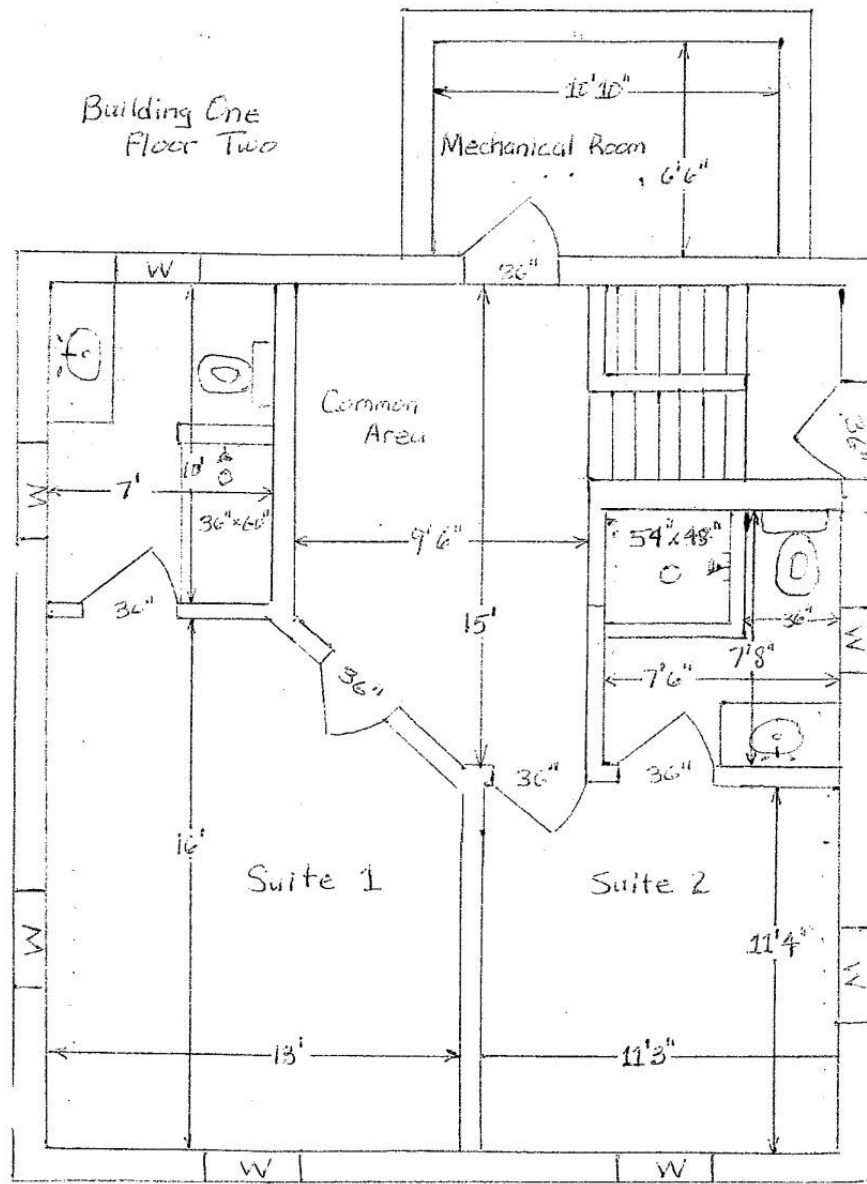

A simple hand drawn floor plan or elevation goes a long way towards understanding the size, mass and proportion of a new addition, porch, deck or ramp! You don't have to be an architect to sketch your house, grid paper is provided in Appendix D to help get you started!

Exterior View Bldg. 2

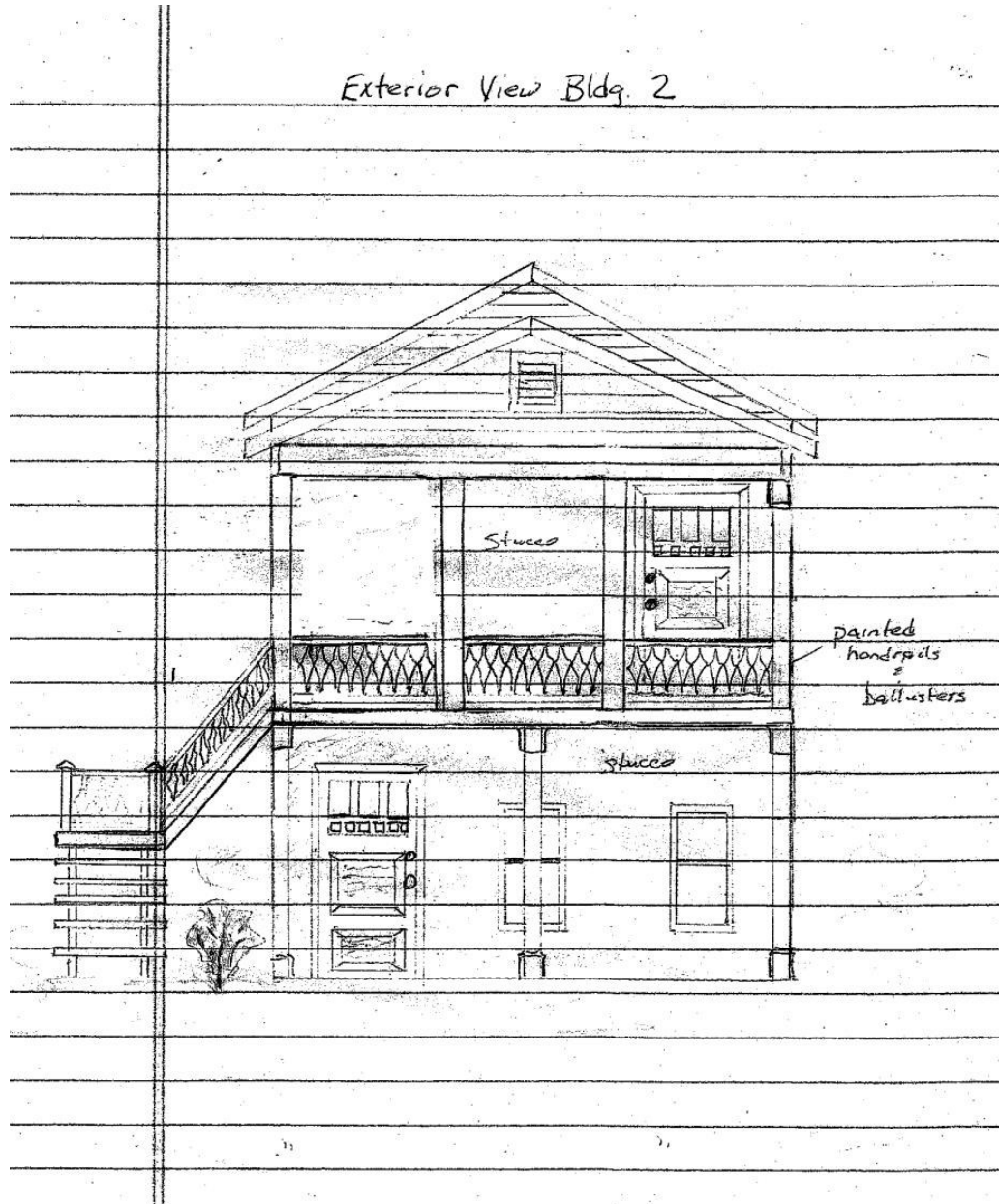

Signage

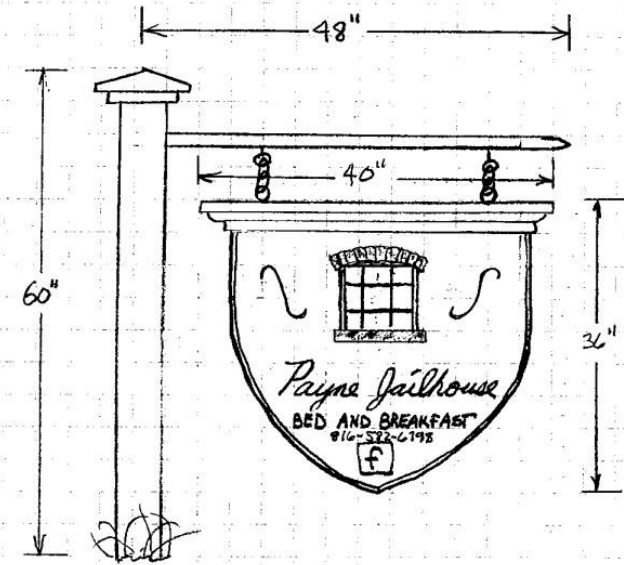

A simple hand-drawn floor plan or elevation goes a long way to understand the size, mass and proportion of a new addition, porch, deck or ramp! You don't have to be an architect to sketch your house, grid paper is provided in Appendix D to help get you started!

Boarding House District Architectural Styles and Forms

Single-family residences, boarding houses and apartment buildings are the dominant functional and architectural building types found in the Boarding House Historic District. The residential architecture of the District represents a range of styles from the late nineteenth century Victorian styles through the New Traditional style with its postmodern interpretation of historical styles, as well as the gamut of nineteenth and twentieth century folk house forms.

Throughout the nation's history, its citizens erected modest dwellings constructed of locally available materials without stylistic embellishments. The early colonists brought with them the building traditions of Europe and, using locally available materials, adapted them to their new communities. Frame buildings constructed of hewn timbers and covered with thin wood siding dominated the early folk building in New England, where massed plans more than one room deep became the norm. In the early settlements of the Tidewater South, frame houses that were one room deep became common. As settlement expanded to the West, the Midland tradition of log buildings evolved from blending the two Eastern traditions.

Simplified vernacular interpretations of Victorian forms (Folk Victorian) were popular throughout the country in the late nineteenth century. These were closely related to and often based on National Folk forms, representing more elaborate, high-style designs applied to the same forms. The character of American folk housing changed significantly as the nation's railroad network expanded in the decades from 1850 to 1890. Builders of modest

dwellings no longer relied on local materials. Instead, railcars could rapidly and cheaply move mass manufactured construction materials (pre-cut lumber, nails, window and door frames and ornamental details) from distant plants. It was not long until vernacular houses of light balloon or braced framing replaced hewn log dwellings. Despite the change in building technique and materials, the older folk house shapes persisted. The resulting houses were simple dwellings defined by their form and massing, but lacking identifiable stylistic characteristics. Even after communities became established, folk house designs remained popular as an affordable alternative to more ornate and complex architectural styles. These traditional prototypes and new innovative plans comprise distinctive families of residential forms that dominated American folk building through the first half of the twentieth century.



Historic housing example from the district, 109 Saratoga, 2014.

Housing forms nationwide evolved once again following the lean building years of the Great Depression and World War II. As in previous decades, the modest size of the new housing forms and the use of mass-produced and/or prefabricated components made them affordable. Minimal Traditional dwellings evolved from earlier historical revival styles, while the Ranch house was a new form that reflected changes in attitude and aesthetics.

This area of Excelsior Springs is unique in the number of resources designed to house temporary residents of the city during the height of the health movement driven by the presence of the springs, both as purpose-built apartment buildings or boarding houses and converted single-family dwellings. Most of the boarding houses are two stories or taller, fill their entire lot, and have more than one entrance. The variety of architectural styles and forms present in the district is a factor of the era in which the majority of resources were constructed. Popular forms represent a wide variety of influences which is indicative of the late nineteenth and early twentieth century. Aside from the resources that are clearly identifiable as formal architectural styles, the remaining modest dwellings have simple forms and restrained ornament. Roof form is the primary characteristic used to identify these resources in the District. Resources were identified by their roof type alone, including Front-Gable, Side-Gable, Cross-Gable, and Hipped types. These dwellings are typically one to two-and-one-half stories.

Victorian Period Residential Architectural Styles

The earliest residences in the Boarding House Historic District were constructed between 1889 and 1911. While most of these early dwellings are

small, vernacular interpretations of popular architectural styles, there are several high-style examples of Victorian-era dwellings in the Survey Area, primarily the Queen Anne style. Other resources that date to this era represent the Folk Victorian style with simpler floor plans and more restrained ornament.



Example of Folk Victorian style, 436 East Broadway, 2014.

The Victorian Era in America (roughly 1860 to 1900) occurred during a time of rapid industrialization when building components were mass produced and easily shipped via the seemingly ever-expanding network of railroads. Mail-order catalogues, plan books, and builders' guides helped to spread these styles quickly to cities and towns throughout the country. The flexibility provided by the newly popularized balloon frame allowed irregular floor plans, which was a departure from the traditional arrangements of square or rectangular "pens." The availability of standardized lumber, provided by the local lumber yard or shipped in by rail,

and mail-order trims produced forms that moved beyond the basic cube with protruding bays, multiple gables and towers ornamented with shingles, friezes, spindles, ornamental windows, and wrap-around porches.

Eclectic Period Residential Architectural Styles

Virginia McAlester, author of “A Field Guide to American Houses”, divides the Eclectic Period of American residential architecture into three sub-periods: Anglo-American, English and French Period Houses; Mediterranean Period Houses; and Modern Houses. The Eclectic Movement drew inspiration from American Colonial-era architecture, as well as the architecture of Europe. Designs emphasized strict adherence to stylistic traditions and minimal variation and innovation. During the same time period, and in contrast to the European and Colonial American-influenced designs, Modern houses also appeared. Dwellings in this subcategory represent the burgeoning impact of the Arts and Crafts Movement, Frank Lloyd Wright’s Prairie School and European modernism in the early twentieth century. The National Register of Historic Places differentiates between the Revival styles of European and Colonial American antecedents and the distinctly American styles reflecting influences emanating from Chicago (Prairie School) and California (Arts and Crafts). Under the National Register classification of “Late 19th and Early 20th Century Revivals,” McAlesters’ Anglo-American, English, and French Period Houses are synonymous with Colonial Revival, Classical Revival, Tudor Revival, Late Gothic Revival, Italian Renaissance, and French Renaissance styles. The National Park Service general category of “Late 19th and Early

20th Century American Movements” includes residential architecture in the Prairie School and Bungalow/Craftsman styles.

Post-World War II Housing Types

Following World War II, there was a distinct shift in American residential architecture. Modern styling and simplicity replaced the period architecture popular in the pre-war era. The 2012 NCHRP Report 723 outlines the national context for postwar housing and a process for identifying and evaluating the various property types that were constructed in great numbers during this time period. The most common property types constructed between 1940 and 1975 include Minimal Traditional, Transitional Ranch, Ranch, Raised Ranch and Split-Level. Some designs reflected regional preferences; others resulted from new technologies and/or energy conservation parameters. There are very few examples of these mid-century housing forms in the District, illustrating how few undeveloped lots remained after the area was initially settled.



Example of the Ranch form, 420 East Broadway, 2014.

Other Property Types

The district contains two purpose-built three-story apartment buildings. These rectangular buildings have stone foundations and brick walls with minimal applied ornament, in accordance with the property type. The colonnaded porch that covers the entire front facade is the character-defining feature of this type of apartment building. The apartment building at 328 East Broadway is an excellent simple example of a colonnaded apartment building. The colonnaded porch is missing from 408 East Broadway, compromising its integrity and rendering it non-contributing.

This survey also identified one religious property (Barbee Memorial Presbyterian Church, 438 Benton Avenue) and one former educational resource (Carnegie Public Library, 339 East Broadway). There is also one commercial resource that is non-contributing due to its recent construction date. Because the survey included so few examples of these property types, it is not possible to define characteristics for the buildings in each category. However, it is worth noting that all have exterior architectural treatments that reflect conscious design choices specific to their functions and periods of construction.

Additionally, the reconstructed Crystal Lithia spring pavilion is included within the district boundaries. The replica pavilion was built ca. 2009 and thus is not considered a contributing structure; however, the well site itself is a historic resource that should be preserved.



Rebuilt Crystal Lithia Spring Pavilion, 403 Benton Avenue, 2014.



Example of a three-story apartment building, 106 Saratoga, 2014.

Gable Front and Wing House:

The Gable Front and Wing house form gained popularity in small towns and rural areas as settlers brought with them earlier stylistic influences such as Greek Revival, Gothic Revival, and Victorian. In this form, a secondary side-gable block placed perpendicular to the main gable-front gives the house its distinctive L-shaped massing. Architectural ornament is minimal. Both the one-story and two-story forms became common in the Midwest in the late nineteenth century. The residence at 201 South Francis Street (c.1900) is a good example of the Gable Front and Wing house, with its steep cross-gable roof, narrow windows, and minimal ornament.



Example of Gable Front and Wing form, 201 South Francis Street, 2014.

Hipped Roof with Lower Cross Gables:

The survey identified several resources solely by roof type with a hipped roof and lower cross gables. These asymmetrical forms are the vernacular versions of the Queen Anne style. The primary one- or two-story block of the house has a hipped roof. Gabled wings or dormers projecting slightly from the front elevation often have shallow peaks. Additional details, such as patterned shingles, verge boards, finials, and cresting, emphasize the complexities of the forms but are used sparingly on these simplified designs. Eclectic fenestration adds to the intricacy of the Queen Anne designs. Window patterns include simple one-over-one double-hung sashes, front-gable picture windows, narrow paired windows, and single panes surrounded by small colored glass squares. One-story porches are common and accentuate the asymmetry of the façade. They always address the front entrance area and cover part or all of the front façade. The house at 417 Benton Avenue is a compact one-story dwelling with a primary hipped block and a projecting gabled wing. A small porch connects the two sections. Two-story examples of this form in the District exhibit more overt references to the Queen Anne style, such as the house at 409 East Broadway.



Example of Hipped Roof with Lower Cross Gable form, 417 Benton Avenue, 2014.

Pyramidal Folk House:

The Pyramidal subtype of the National Folk House form evolved from the earlier I-house and Hall & Parlor forms during the turn of the twentieth century. They are found in rural areas throughout the country. These simple forms have a center entry hall flanked by single rooms on either side. The house is deeper than the one-room I-house and capped with a steep pyramidal (equilateral hipped) roof. The pyramidal folk house is one or two stories with a simple, often symmetrical front façade. These wood frame houses were often built in areas with access to mass-produced materials distributed by rail. They were the upgraded farmhouses and early houses constructed in new towns. The pyramidal folk house often employed the balloon frame, a light-weight wood frame whose vertical members rose the entire height of the house. The railroad increased the accessibility of the primary components of the balloon frame, primarily longer pieces of lumber and mass-produced metal nails. Alterations and additions were often constructed on the rear elevation, though full-width or even wrap-around porches were common. The District has several examples of the pyramidal folk house form. The dwellings at 418 Broadway and 402 East Excelsior Street are examples of this form, with narrow, rectangular plans and center entrances. The residence at 418 East Excelsior Street is an example of a one-story pyramidal folk house form.

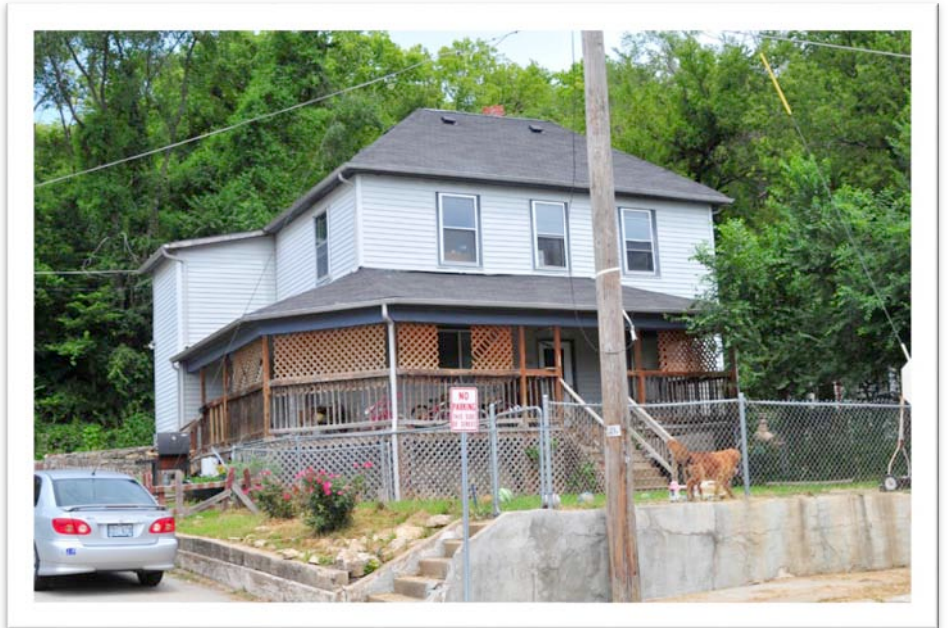

Example of Pyramidal Folk form, 402 East Excelsior Street, 2014.

Queen Anne: 1880 - 1910

The Queen Anne style was extremely popular in the Midwest during the late 1800s to about 1910, and was often used in smaller, more-rural communities such as Excelsior Springs up to World War I. The style came to America from England during the 1880s, evolved from a style developed by a group of nineteenth century architects. The style was named for Britain's Queen Anne, who reigned between 1702 and 1714 when classical ornament was often applied to traditional medieval structures. A Queen Anne residence's most-character-defining feature is its overall form. The massing of Queen Anne homes features protruding cross-gables and turrets that contribute to an asymmetrical form. Additional exterior decoration was achieved through wall overhangs, voids, extensions and the application of a variety of materials.

As the Queen Anne style evolved, the emphasis on patterned wood walls became more pronounced. The one-story partial, full, or wrap-around porches that extended across the façades of these houses typically feature turned or jigsawed ornamental trim. Extensive one-story porches are common and accentuate the asymmetry of the façade. They always address the front entrance area and cover part or all of the front façade. It is not uncommon for these porches to extend along one or both sides of the houses. The most common configuration is the hipped roof with lower cross gables. This shape subtype commonly incorporates towers or turrets. The Free Classic Queen Anne incorporates classical design elements such as the Palladian window, dentils, and classical columns.



Example of Queen Anne style with Free Classic ornamentation,
101 Linden Avenue, 2014.

Queen Anne: 1880 - 1910

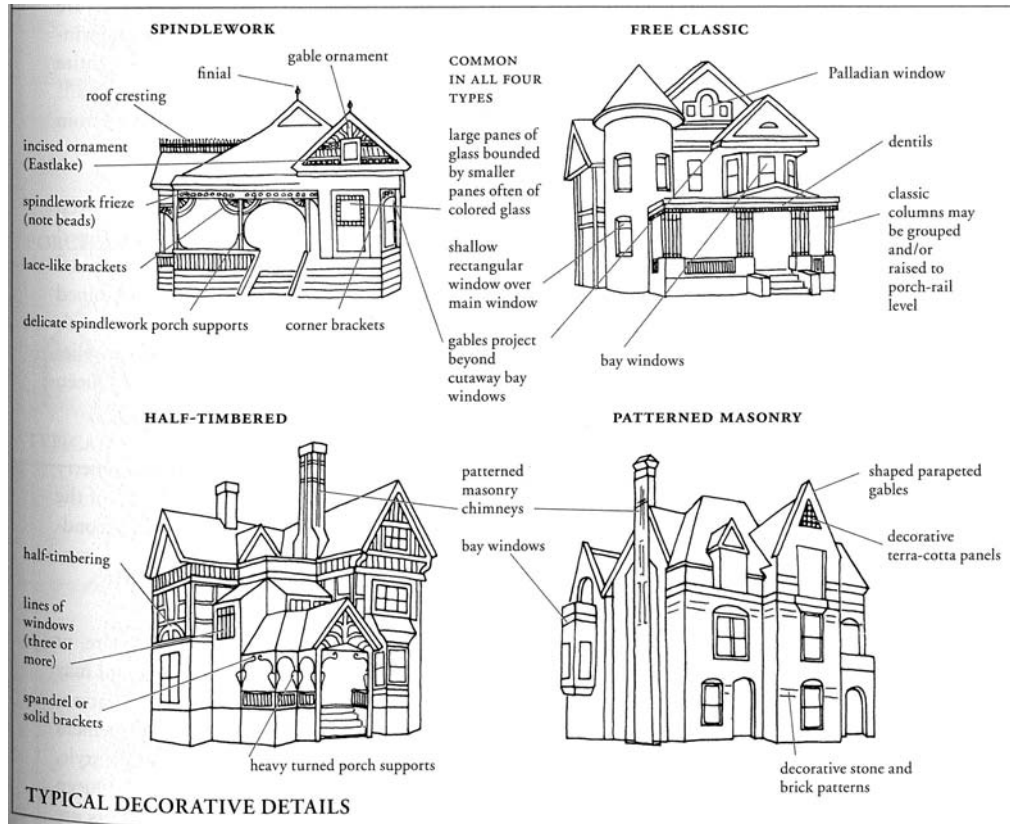

Source: *A Field Guide to American Houses*, 347.

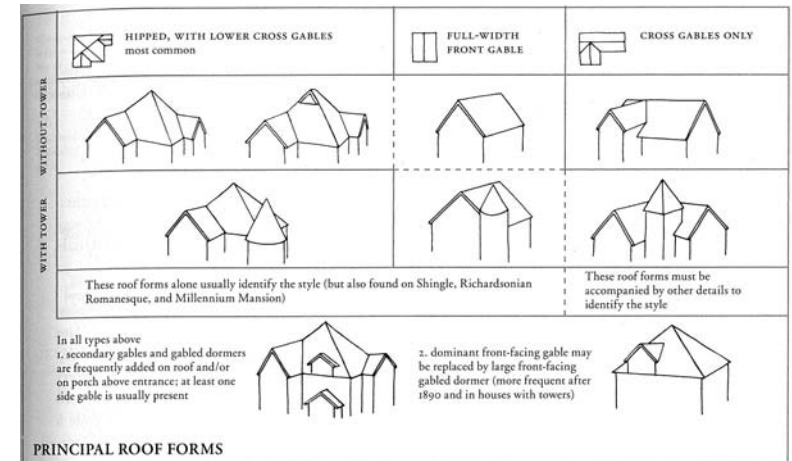

Source: *A Field Guide to American Houses*, 347.



Example of Queen Anne style with hipped roof and lower cross

Folk Victorian: 1880 - 1910

The Folk Victorian style reflects the simplification of earlier Victorian styles combined with the influence of other styles such as the Italianate or Gothic Revival. These dwellings are based on National Folk forms and were made possible with the advent of the railroad. Folk Victorian dwellings have simpler rectangular or L-shaped footprints and minimal ornament, often relegated to the porch and the gable ends. Several resources in the District exhibit elements of the Folk Victorian style, with slightly more ornament than a National Folk home. The houses at 205 South Francis Street, 512 Isley Boulevard, and 305 Saratoga Street are intact examples of the Folk Victorian style .



Example of Folk Victorian style, a very common house type in the district, 205 South Francis Street, 2014.

Folk Victorian: 1880 - 1910

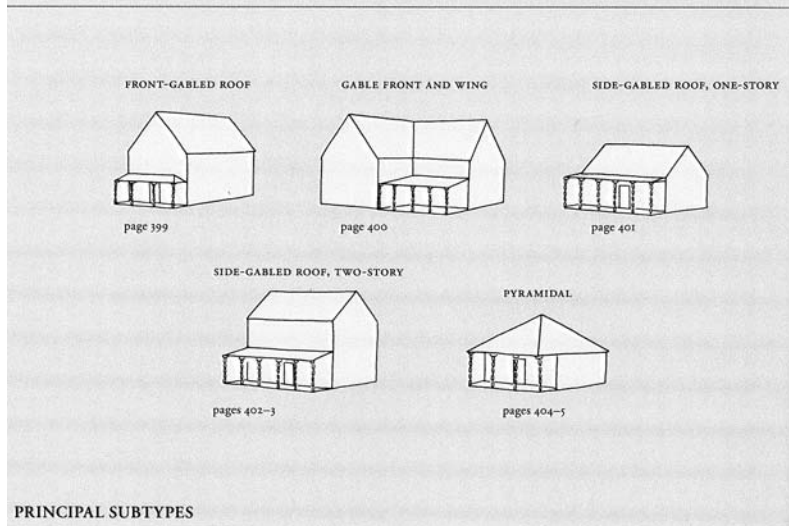

Source: *A Field Guide to American Houses*, 396.



Example of Folk Victorian style, 305 Saratoga Street, 2014.



Example of Folk Victorian style, 512 Isley Boulevard, 2014.

Colonial Revival: 1890 - 1955

The term “Colonial Revival” refers to the rebirth of interest in the styles of early English and Dutch houses on the Atlantic Seaboard. The Georgian and Adams styles, often combined, form the backbone of the revival styles. Those built in the late nineteenth century were interpretations of the earlier colonial style, while those built from about 1915 to 1930 were more exact copies of the earlier adaptations. As their use continued into the mid-twentieth century, the style became more simplified. Several resources express the Colonial Revival style in some way, through form or ornament. The residence at 508 Isley Boulevard is an excellent example of the Dutch Colonial subtype of the Colonial Revival. Character-defining features include the gambrel roof and symmetrical façade.



Example of Dutch Colonial Revival, a sub-type of the Colonial Revival style, 508 Isley Boulevard, 2014.

Craftsman: 1905 - 1930

Craftsman houses date from circa 1905 through 1930. Most evolved from the early designs of Charles Sumner Greene and Henry Mather Greene, who practiced architecture in California from 1893 to 1914. The Greenses designed both elaborate and simple bungalow houses that incorporated designs inspired from the English Arts and Crafts movement and from Asian architecture. Popularized by architectural magazines and builder pattern books, the one-story Craftsman house became popular nationwide during the early decades of the twentieth century as the most fashionable style for a smaller house. Identifying features include low-pitched roofs; wide eave overhangs, often with exposed roof rafters; decorative beams or braces under gables; and full- or partial-width porches supported by square piers. Sixteen resources represent the Craftsman style in varying degrees, making it the most common stylistic expression in the District. The low-pitched roof with exposed rafter tails, front gabled porch and dormer, and multi-light double-hung windows on the houses at 432 Isley Boulevard and 510 Isley Boulevard clearly exemplify Craftsman design.

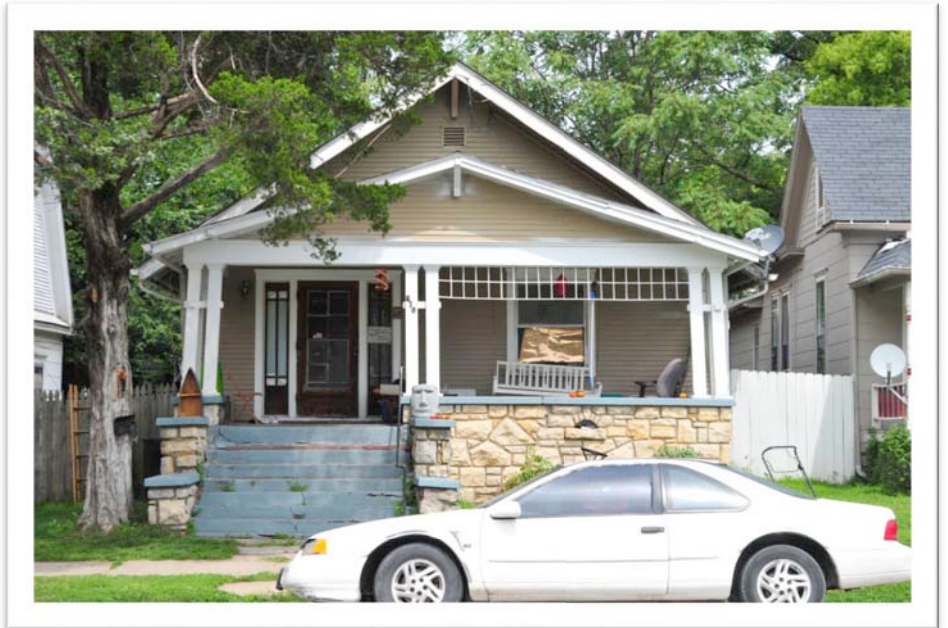

Example of Craftsman style, 510 Isley Boulevard, 2014.

Craftsman: 1905 - 1930

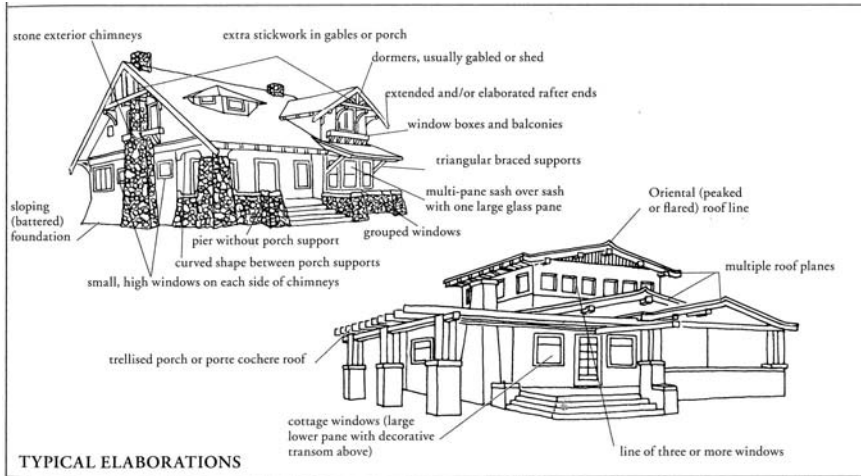

Source: *A Field Guide to American Houses*, 569.



Example of Craftsman style, 423 Isley Boulevard , 2014.

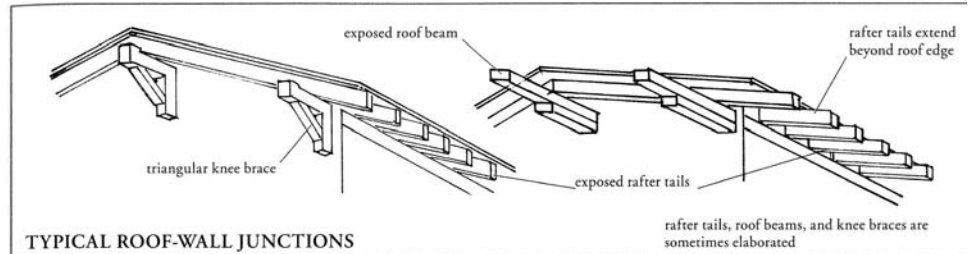

Source: *A Field Guide to American Houses*, 569.

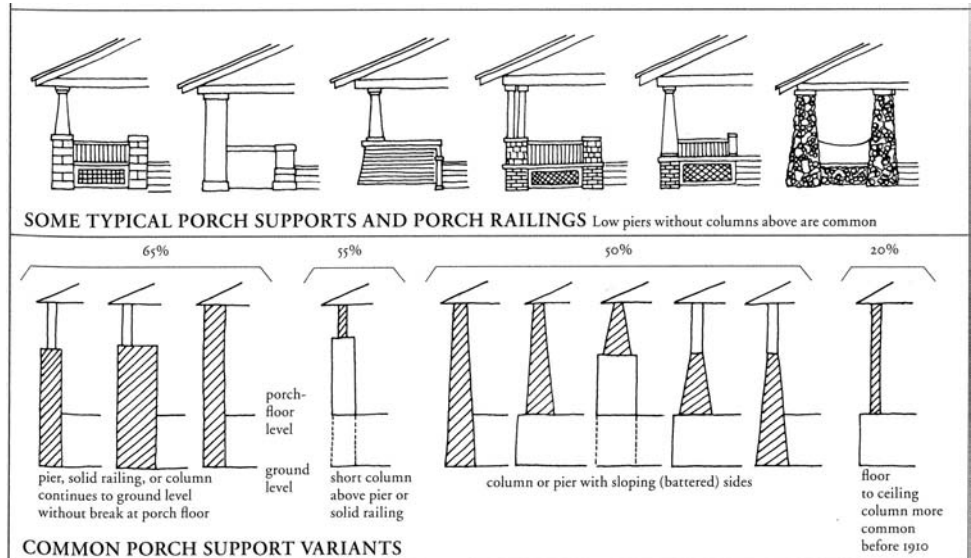

Source: *A Field Guide to American Houses*, 569.

Prairie School: 1900 - 1920

Prairie School is a uniquely American architectural style that originated with Frank Lloyd Wright and other Chicago architects around the turn of the twentieth century. Pattern books spread the style throughout the Midwest over the next decade. One variation of the Prairie School common in the Midwest was the two-and-one-half-story dwelling with a front-gable roof and flared, overhanging eaves. The gable end often has a Palladian window and a shallow gabled pediment caps the full-width front porch (528 Benton Avenue).

A Prairie style subtype is known as the American Foursquare and Gabled Roof. Vernacular examples were widely spread through magazine articles that popularized the style, and later through pattern books. Most of the Prairie style houses within the Boarding House Historic District were constructed between 1905 and 1922.

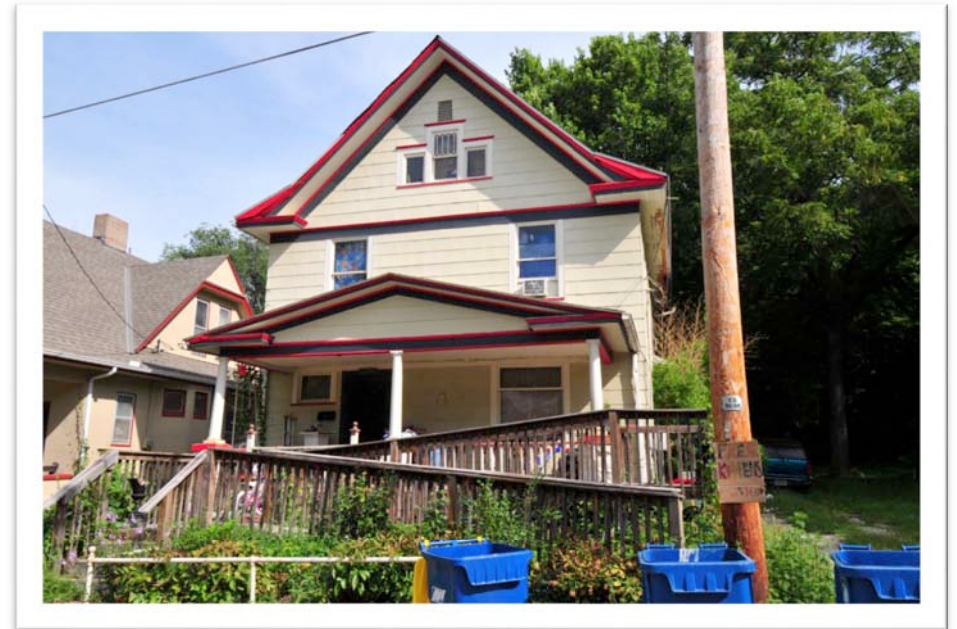

Example of Prairie School style, 528 Benton Avenue, 2014.

Ranch House: ca.1935 - 1975

The basic Ranch house is a low, wide one-story building with moderate to wide eaves. The low-pitched roof may be gabled or hipped; the façade may be symmetrical or asymmetrical; and the plan may or may not include an integrated garage. The survey identified just one example of the Ranch form: 420-424 East Broadway. The simple dwelling has a side-gable roof, an asymmetrical façade with a narrow front-gable wing, stone veneer siding, a variety of window types and sizes, and an attached garage.



Example of a Ranch home, 420-424 East Broadway, 2014.

New Traditional: 1990 - Present

Renewed interest in historical styles that began in the late 1970s continued to influence residential design into the twenty-first century. Following the Postmodern era, when features were abstracted and exaggerated, New Traditional designs emerging in the 1990s employed more historically accurate proportions, forms, and details. Although New Traditional designs reflect a more thoughtful interpretation of historical styles, aspects of the building, whether it is materials, siting on the lot, or relationship of features to one another, still communicate its recent construction date. However, the use of this approach can be appropriate for infill construction in a dense residential neighborhood, particularly one with a wide variety of historic architectural styles and forms. As part of a recent redevelopment project, thirty one-and-a-half-story New Traditional Craftsman Bungalows line the stretch of East Excelsior Street from Main Street to Linden Avenue, as well as the 300 Block of Foley Street and two lots on East Broadway. Eight of these dwellings are located in the District because they were constructed on lots that previously contained historic resources..



Example of New Traditional style, 312 East Excelsior, 2014.

Vernacular Apartment Buildings: 1900 - 1980

The City of Excelsior Springs, being a popular summer destination in the nineteenth and early twentieth centuries, led to the popularity of boarding houses and apartment buildings with rooms that could be rented by the day, week or month. Many apartment buildings started off as single family houses or were purpose built as boarding houses. Typically these buildings are two to four stories in height and have a prominent central entry door which leads to an interior hall and stairs to upper floors. They can have front and rear porches, exterior stairs, flat or pitched roofs. The apartment buildings which once were houses typically have exterior stairs on the side or rear of the property leading to the upper floor units. Apartment buildings are commonly found closer to commercial centers, but can also be found throughout the city.

Defining characteristics of Excelsior Springs Vernacular Apartment Buildings include: (1) two to three stories in height; (2) prominent front entrance located in the front façade; (3) developed front porches and upper balcony spaces; (4) a variety of exterior materials and combinations of styles; and (5) may have elements of more high-style commercial and residential buildings or may be more residential vernacular, reflecting styles and building forms from various styles with the most common being Queen Anne and Folk Victorian.



Example of Vernacular Apartment Building which likely was once a Boarding House, 410 East Broadway, 2014.



109 Saratoga, 2014.



103 Saratoga, 2014.



335 East Broadway, 2014.



408 East Broadway, 2014.

Colonnade Apartment Buildings: 1900 - 1930

This style of multi-family dwelling is recognized officially as the Kansas City Colonnade Apartment Style. It evolved around the turn-of-the-century with the first examples and precedents seen ca. 1880. The style applied Beaux Arts and Neoclassical elements such as symmetry, central elevated entrance and the use of classical orders (columns, capitals, detailing and ornamentation). The buildings can also incorporate details from other architectural styles and eras, and vary from highly ornamented to simplistic. The predominant architectural feature for this building type is the colonnaded open front porch. There are several sub-types such as the “Classical Colossal Column Porch,” the “Square Brick Column Porch”, and the “Transitional Colonnade Apartment Building”. For additional information regarding colonnade apartment buildings and sub-types, refer to the Multiple-Property National Register Nomination form which describes in both written and photographic format the variations of this architectural style. These buildings are easily recognizable and can be found throughout Kansas City and the surrounding metropolitan areas.



Example of a Square Brick Column Porch Colonnade Apartment Building,
328 East Broadway, 2014.

4

ARCHITECTURAL STYLES

Commercial, Civic, and Religious

While the majority of commercial and civic buildings in Excelsior Springs are located within the downtown or in commercial business parks, there are a few commercial buildings located within residential neighborhoods.

There are two basic forms or building types for traditional ‘Main Street’ downtown buildings typically found in small or developing communities. They are known as the One-Part Commercial Block and Two-Part Commercial Block buildings. These buildings range from one to four stories in height and were commonly constructed of masonry with large, framed storefronts. While not specifically an architectural style, the building types can be further defined by a style such as: Victorian, Modern, Neoclassical, or others. The main difference between One-Part and Two-Part Commercial Block buildings is number of stories and use. Two-Part Commercial Block buildings typically share an exterior wall with another adjacent structure, are two or more stories in height and have a distinct horizontal separation between the first and second floors. Typically, the first floor was utilized as retail or other public business with the second (and upper floors) serving as private offices or residences. In contrast, One-Part Commercial Block buildings are a single story, were typically utilized as a retail store and occasionally appear as a stand-alone building.

For additional information regarding commercial, civic and religious buildings and commercial architectural styles, refer to the Hall of Waters Historic District Design Guidelines.



Barbee Memorial Presbyterian Church, 438 Benton Avenue, 2014.

Commercial Storefront Terminology



- Signage
- Transom Windows (May be clear glass or leaded glass)
- Awning
- Storefront Display Windows
- Corner Post
- Divided Storefront Window Mullions
- Entry Doors

Graphic by Susan Richards Johnson & Associates, Inc. 2014.

One-Part Commercial Block: 1900 - 1965

One-Part Commercial Block buildings were often constructed to simply meet the needs of a single business and can be found within commercial centers or within residential neighborhoods as a stand-alone building. They are typically modest structures, rectangular in shape and made of masonry with simple brick detailing at parapets and cornices. It is most common for these structures to have flat roofs that slope to the rear of the building. The main character defining features for this building type is a large storefront window system set between masonry pilasters. While brick is the most common, building facades can be clad in stone, glazed terra cotta, pigmented structural glass (also known by its product name “Vitrolite”), metal or wood cladding. Storefront systems sometimes will have leaded or colored glass transom windows or additional decoration such as tile or carved stone around the main entry. Additionally, it is common for the structures to have signage and fabric awnings to shade the large storefront windows.

For additional information and examples, refer to the Hall of Waters Historic District Design Guidelines.



Example of a One-Part Commercial Block Building. This building is a new construction in-fill building with historical design elements (proportion, massing and materials, 300 East Broadway, 2014.

Gothic Revival: 1905 - 1935

There are few examples of the Gothic Revival Style in Excelsior Springs found in the religious structures in both the Hall of Waters Historic District and the Boarding House Historic District. The Gothic Revival Style was popularized in America by the first house plan book published in the country by Alexander Jackson Davis in 1832. In the 1870's, the writings of John Ruskin popularized the use of the Gothic Revival Style for public and religious buildings. The defining characteristics of the Gothic Revival Style include: (1) steeply pitched roof lines, often with cross gables; (2) windows extending into gables with pointed arch heads; (3) tracery windows; and (4) turrets or towers.



Example of a Gothic Revival church, 438 Benton Avenue, 2014.

Classical Revival: 1905 - 1935

After the Civil War, commercial centers tended to become specialized according to administrative, retail, wholesale, industrial, or recreational use. New building types and reinterpretations of traditional building types appeared as styles changed. Classical Revival style reflects the influences of historic architecture derived from European and American antecedents. Features include a symmetrical façade punctuated by articulated pilasters that separate the individual bays, stone trim, and classical ornament.



Example of a Classical Revival civic building, 339 East Broadway, 2014.

For additional information and examples of commercial architectural styles, refer to the Hall of Waters Historic District Design Guidelines.

Introduction

The intent of the design guidelines for rehabilitation is to help homeowners and business owners understand their historic building and the materials it is made out of. This section also gives advice for rehabilitation work, as well as, provide guidance on what types of work will require a Certificate of Appropriateness and what work is considered Maintenance. These guidelines are not intended to inhibit change, new construction or new architectural styles, and encourage new construction that complements the existing historic buildings, historic neighborhood and streetscapes.

When beginning a project, it is recommended to research the property through the Excelsior Springs Museum and Archives. Historic photographs or other recordation of what the property looked like can be very helpful when repairs or replacement materials are needed so they match the typical construction and materials for the architectural style and time period the building was built.

All proposed development, construction, rehabilitation, modification or other such work to the exterior of buildings within the boundaries of the Boarding House Historic District is subject to review by the local Historic Preservation Commission. Additionally, all work (interior and exterior) must be done in accordance with current building codes and ordinances. For example, there are City ordinances about zoning, parking, maintenance and upkeep of properties and dangerous buildings code enforcement. A building permit may be required for specific work. For the most current City ordinances, information about building permits and building codes adopted by the City of Excelsior Springs, visit their website: www.cityofesmo.com

or you can review The City Code at the Hall of Waters, 201 East Broadway, or at the Mid-Continent Public Library, located at 1460 Kearney Road, or by purchasing online from the International Code Council.

These Design Guidelines for Rehabilitation for historic properties in Excelsior Springs are based on the Secretary of the Interior's Standards for the Treatment of Historic Properties. Developed by the National Park Service and Secretary of the Interior, these standards are intended to define the different approaches used for historic properties. There are four treatment approaches which guide any maintenance or proposed changes to a historic property.

Preservation - focuses on the maintenance and repair of existing historic materials and retention of a property's form as it has evolved over time.

Rehabilitation - acknowledges the need to alter or add to a historic property to meet continuing or changing uses while retaining the property's historic character.

Restoration - depicts a property at a particular period of time in its history, while removing evidence of other periods.

Reconstruction - re-creates vanished or non-surviving portions of a property for interpretive purposes.

Maintenance

Regular maintenance is critical for the upkeep of every building, regardless of its age or historic designation. Planned preventative maintenance and regular repairs are the most sustainable way to protect a building from deterioration due to the effects of time and weather. It is especially important to develop a regular maintenance plan for a historic building as a simple fix such as a leaking pipe can grow into a much larger and more expensive issue if left unrepaired. Property owners are not expected to know the building construction trades or technical knowledge required to repair issues. However, it is vital for owners of a historic property to recognize signs of deterioration, water damage, weathering and typical locations where wood rot, water and air infiltration are common. Keeping a building or house weathertight will ensure it will be more comfortable, more energy efficient and that years can be added to the life of the building. It is recommended that all maintenance activities maintain, rather than replace, historic building



©iStockphoto.com/Trigem777

features, in keeping with the Secretary of the Interior's Standards for the Treatment of Historic Properties.

All property owners in the City of Excelsior Springs, regardless if the building is historic or not, are required to keep up their properties per City Ordinance, Section 235. Refer to the specific materials in this section for guidance on repairs and planned maintenance.

Typical Annual Maintenance Inspections and Repairs

- Inspect Roofing for damage (cracked, warped or missing shingles or roofing membrane, inspect metal flashings at roof penetrations and chimneys).
- Clean out gutters and downspouts in the fall and spring.
- Inspect siding, exterior trim and exterior ornament for damage (cracked, warped or missing pieces). Repair or replace rotted wood.
- Inspect foundation for cracks or water infiltration both on the exterior and the interior. Check to be sure the ground around the building slopes away from the foundation to help keep it dry.
- Inspect windows and doors for air leaks, cracked or missing paint, replace broken glass, check caulking adhesion making sure it is intact and is not cracked or missing, check that the window and door operates smoothly and has weather stripping and functioning hardware.
- Paint touch up where paint is cracked, flaking or missing.
- Inspect masonry for damage (cracked or missing mortar, heavy staining/vandalism, remove vines and weeds from growing on the sides of buildings as the vines can cause deterioration to the mortar and the brick).

Secretary of the Interior’s Standards for Rehabilitation

“The Secretary of the Interior’s Standards for the Treatment of Historic Properties are a series of concepts about maintaining, repairing, and replacing historic materials, as well as designing new additions or making alterations. The Guidelines for the Treatment of Historic Properties offer general design and technical recommendations to assist in applying the Standards to a specific property. Together, they provide a framework and guidance for decision-making about work or changes to a historic property.

The Standards and Guidelines can be applied to historic properties of all types, materials, construction, sizes, and use. They include both the exterior and the interior and extend to a property’s landscape features, site, environment, as well as related new construction.” (National Park Service, Technical Preservation Services website: <http://www.nps.gov/tps/standards.htm>)

Rehabilitation is the most common treatment approach for buildings located within the Boarding House Historic Preservation District and allows some greater flexibility for proposed work. These standards should be followed when rehabilitating or altering the materials and features of a property within the district. The Secretary of the Interior’s *Standards for Rehabilitation* are defined as follows:

1. A property will be used as it was historically or be given a new use that requires minimal change to its distinctive materials, features, spaces, and spatial relationships.
2. The historic character of a property will be retained and preserved. The



This Folk Victorian home located in the historic district is an excellent example of a historic property that retains its historic character through its retention of its overall proportions (size, front porch size/location and gable roofs) historic siding, decorative historic wood porch columns and brackets, and overall is well maintained, 205 South Francis, 2014.



The distinctive features of this property include the front porch configuration, wood and stone columns, and unique roof shape with sloped roof ridges and eaves, 223 South Francis, 2014.

Secretary of the Interior's Standards for Rehabilitation (continued)

6. Deteriorated historic features will be repaired rather than replaced. Where the severity of deterioration requires replacement of a distinctive feature, the new feature will match the old in design, color, texture, and, where possible, materials. Replacement of missing features will be substantiated by documentary and physical evidence.

7. Chemical or physical treatments, if appropriate, will be undertaken using the gentlest means possible. Treatments that cause damage to historic materials will not be used.

8. Archeological resources will be protected and preserved in place. If such resources must be disturbed, mitigation measures will be undertaken.

9. New additions, exterior alterations, or related new construction will not destroy historic materials, features, and spatial relationships that characterize the property. The new work will be differentiated from the old and will be compatible with the historic materials, features, size, scale and proportion, and massing to protect the integrity of the property and its environment.

10. New additions and adjacent or related new construction will be undertaken in such a manner that, if removed in the future, the essential form and integrity of the historic property and its environment would be unimpaired.



Left: Example of a historic porch bracket which could be utilized to make replacement pieces, Kirksville, Missouri, date unknown. Right: Example of an outbuilding appropriately located in the rear of the lot, matching the historic home's architectural style and materials, Liberty, Missouri, 2006.



Left: Example of archeological resources uncovered during excavation, National Park Service Website. Right: Example of an incompatible front porch alteration which has negatively impacted the integrity of the historic property and is not easily reversed, 423 East Broadway, 2014.

How to Use the Rehabilitation Guidelines

The Rehabilitation Guidelines for the various materials and building features/elements found within this chapter are based upon the Secretary of the Interior’s Standards for Rehabilitation and the National Park Service Preservation Briefs. Each section includes photographs, illustrations, and a detailed written description of the Recommended and Not Recommended approaches for owners who are rehabilitating their property’s exterior architectural materials and features. Also included is a bulleted list of exterior rehabilitation treatments including repairs, additions, alterations and new construction categorized into what is considered maintenance and what will require a Certificate of Appropriateness. The Historic Preservation Commission and City Planning and Zoning Director utilize these design guidelines along with adopted City Building and Maintenance Codes and Ordinances to determine the appropriateness of the proposed work on a case-by-case basis.

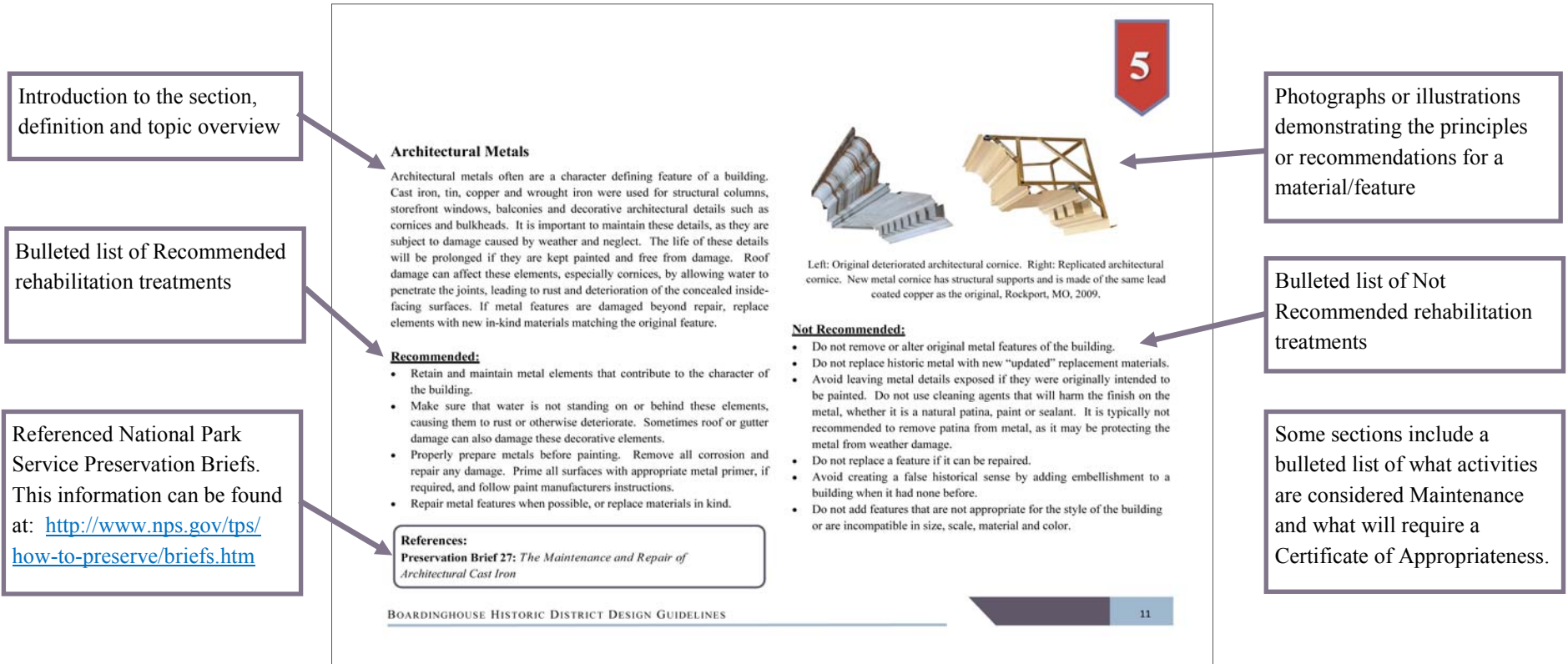

Masonry

Stone, brick and terra cotta were the most popular exterior materials used for commercial and some residential buildings in Excelsior Springs. Masonry was readily available in Missouri and therefore, was used for most commercial buildings in the late nineteenth and early twentieth centuries. Masonry was a material of permanence and in a burgeoning city such as Excelsior Springs, the buildings were constructed to last. As a result of the ongoing maintenance and care of these buildings, many of Excelsior Springs' historic masonry buildings are over a century old.

In order to maintain these buildings for future generations, it is imperative that the correct materials and methods are utilized. Equally important is to hire a mason that has an expertise with historic buildings and a knowledge of historic building techniques. Repointing is an important part of maintaining historic masonry. This is the term used for removing deteriorated mortar and replacing it with new mortar. Mortar bonds the brick, or stone, masonry units together and keeps water out of the wall system.

Repointing with an appropriate mortar mixture that is consistent with the original mortar is important for several reasons. If new mortar is too soft compared to the original mortar, it may not be strong enough to hold the brick or stone together and also may not adhere properly to the masonry units. Additionally, mortar that is too hard may expand and contract at a different rate than the surrounding historic masonry and rather than the mortar deteriorating, the brick or stone will deteriorate (spall, delaminate and crack) causing permanent damage to the building.



The masonry (stone) front porch of this Craftsman style home is an essential character defining feature, 432 Isley Boulevard, 2014.

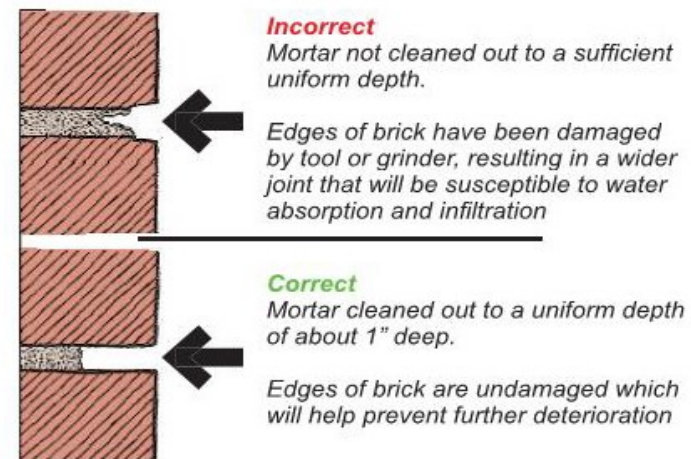

Image from Architectural Graphic Standards, Ninth Edition

New mortar should match the physical properties of the original, historic mortar for aesthetic reasons. Replacement mortar should match the original mortar in color, texture, aggregate and joint profile. Many historic mortars have variations in aggregate size and colors, as well as a pigmented matrix. Replacement mortar that does not match the original, historic mortar will be an obvious alteration to the building facade.

When removing existing mortar, it is important that removal is done by hand rather than with a power tool. Cutting out old mortar with power tools can cause irreparable damage to the brick and stone.

Masonry should be cleaned using the gentlest means possible, usually with water or other non-abrasive means. The pressure should be less than 300-400 psi to prevent damage to the masonry and mortar. Abrasive methods should not be used because they may damage or remove the protective fire skin of the brick, which prevents water from penetrating the brick.

Preventing water from entering walls will result in historic masonry systems that will last for generations. Once water penetrates an exterior masonry wall, it can cause irreversible damage to the masonry and/or mortar through spalling or deterioration.

When masonry features are damaged, the preferred treatment is to patch them in place with appropriate materials. If the feature or unit is too damaged or is missing, replace them in-kind utilizing salvaged material to match the existing historic masonry. If salvaged material is not available,



Incorrect mortar removal has caused permanent and irreparable damage to the historic brick, Kansas City, Missouri, 2009.



Incompatible Mortar Joints. New mortar installation (right side of the picture) does not match the original (left). Repointing has left mortar on the face of the brick.



Left: Cleaning test on limestone with gentlest chemical cleaner available and low-pressure water rinsed. Right: After image of cleaning, no abrasives or high-pressure water was used. Cleaner did not harm the stone. Kansas City, MO 2010.

new masonry units should be used matching the historic in-kind (dimension, texture, features, color) and matching installation method of the surrounding historic materials. If it is necessary to replace a large amount of masonry features, replacement materials may be used provided they convey the same visual appearance as the historic material.

It is not appropriate to install artificial masonry or stone veneer to the facade of a building to mask original masonry if it did not originally exist. Veneer should be removed in its entirety if it has not achieved historical significance.

Painting Masonry

Historically, most masonry buildings were not painted. When buildings were painted, it was commonly done to hide poor masonry work or mismatched or deteriorated brick or stone. Buildings may also have been painted with the desire to protect the masonry from further deterioration after it had been sandblasted or otherwise damaged. Typically, painting masonry is not encouraged. Additionally, application of liquid ‘waterproofing’ or ‘sealants’ are not recommended as they can cause permanent damage to masonry when water becomes trapped behind the ‘sealer’. When removing paint from masonry, care should be taken not to damage the masonry. If masonry is to be painted, care must be taken to choose a ‘breathable’ paint product for masonry. When a latex or ‘skin forming’ paint is used, it traps water behind the paint layer and causes permanent damage to the masonry (spalling, cracking and deterioration).

The removal of paint is typically accomplished through chemical methods.

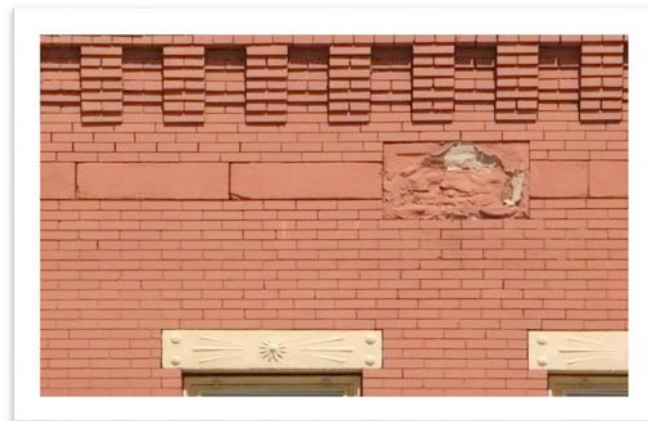

Brick and stone masonry have been painted in the past, note the deteriorated stone with peeling paint, Excelsior Springs, Missouri, 2009.

Testing in inconspicuous areas should be done prior to moving forward with paint removal on the remainder of the building. Stripping should be done utilizing the gentlest methods available, with chemical strippers that have been proven to be safe on historic masonry materials.

Painted Murals

Painted murals on commercial buildings within the historic downtown should take into consideration the following items:

- Size, Scale and Location of mural (can it be seen from the public right of way? Is it located on a primary or secondary façade? Is it located towards the front or the back of the building? How big is the mural?)
- Mural themes are encouraged to resemble the character of the historic context they will be installed on.
- Mural paint must be specially formulated for masonry, to be ‘breathable’ and must be removable in the future.
- Buildings located on either the local or National Historic Register should not have painted murals.
 - Buildings such as the Hall of Waters, The Elms, The Oaks Apartments and the Excelsior Springs Museum and Archives should not have painted murals.
- Painted murals are not recommended in residential areas.
- All proposed painted murals will require a Certificate of Appropriateness.



Top: Painted masonry building before paint removal. Kansas City, MO, 2004.

Bottom: Masonry building after paint removal. Kansas City, MO 2006.

Recommended:

- Test original mortar before new mortar mixture is made. This will enable mason to match original mortar in composition and color.
- Match existing mortar joint profile and appearance.
- Remove loose or deteriorated mortar by hand to ensure protection of brick or stone.
- Test all cleaning methods, including paint removal, prior to beginning project. Always utilize gentlest methods possible that achieve successful results without damaging historic masonry.
- Clean masonry using water or non-abrasive means at a pressure less than 300-400 psi.

Not Recommended:

- Do not use mortar that is too hard or too soft in comparison to existing original mortar.
- Do not remove sound joints in good condition in order to replace all mortar joints to achieve uniform appearance.
- Do not cut out old mortar joints with power tools. This could damage brick or stone.
- Do not sandblast or use other abrasive means of cleaning masonry.
- Do not apply ‘waterproofing’ or ‘sealers’ to masonry. They are often unnecessary and expensive. Masonry wall systems are designed to allow “breathing” (transfer of water vapors from inside a wall through the brick and mortar) and the application of sealants could cause moisture to be trapped inside the masonry, leading to permanent damage such as spalling or cracking.

- Do not apply non-breathable paint to exterior masonry walls. Most paints that are not specifically designed to be ‘breathable’ for masonry wall systems will trap the moisture behind the paint inside the masonry, causing irreversible damage to the historic masonry and mortar.



Above Left: An example of a stone masonry retaining wall and decorative stone wall. Both are historically important features and should be retained, 103 Temple, 2014.



Below Left: Many of the houses in the district have exposed stone masonry foundations, 111 Temple, 2014.

Recommended (Painted Brick):

- Scrape off loose paint by hand. It is only necessary to scrape paint to the next solid layer. Do not use abrasive methods such as sandblasting or power washing with water pressure greater than 300 psi, which could cause damage.
- Chemical paint remover is acceptable if it is applied correctly.
- Repair damaged masonry, in-kind, prior to repainting.
- Choose color scheme that is appropriate for district. Typically, an earth-tone base with an accent trim color is an appropriate scheme.
- Prepare building surface for new masonry paint, per manufacturer's instructions. This will help new paint adhere to the building and prolong the life of the paint.
- Use a paint that is formulated for masonry and that is compatible with the paint that currently coats the building and one that is appropriate for masonry that will allow the masonry to 'breathe.'

Not Recommended (Painted Brick):

- Do not paint a building that has not been painted.
- Do not utilize abrasive means to remove paint from building.
- Do not use an inappropriate color scheme. Because buildings in a historic district are typically located very close to or adjacent to each other, consider the neighboring buildings when choosing a color scheme.

- Do not use paint that is not 'breathable' or not compatible with masonry.
- Do not paint a building that has damaged or deteriorating masonry, without first correcting the problems.
- Do not skip the preparation stage of painting. Priming the building will help new paint adhere, thus avoiding peeling paint soon after the job is complete.

What is considered Maintenance and what requires a COA?**Maintenance:**

- Minor repointing work, less than 20% of the building.
- Masonry spot cleaning to remove graffiti or staining.
- Minor brick or stone replacement in-kind.

COA:

- Major repointing work (includes masonry foundations).
- Brick or stone replacement in-kind.

References:

Preservation Brief 1: *Assessing Cleaning and Water-Repellent Treatments for Historic Masonry Buildings*

Preservation Brief 2: *Repointing Mortar Joints in Historic Masonry*

Preservation Brief 6: *Dangers of Abrasive Cleaning to Historic Buildings*

Preservation Brief 38: *Removing Graffiti from Historic Masonry*

Preservation Brief 42: *The Maintenance, Repair and Replacement of Historic Cast Stone*

Siding and Trim

Residential buildings in the Boarding House Historic District utilized wood cladding and trim as a primary character-defining feature. Wood cladding includes clapboard siding, wall shingles and board and batten applications. Wood was also utilized in the construction of columns, brackets, porches, fascias and eaves and other decorative elements. Many styles of houses were defined by the use of decorative wood shingles and siding. The Queen Anne and Folk Victorian Styles typically have some application of decorative shingles. These are an example of a character-defining decoration that should be maintained throughout the life of the house.

Substitute sidings, such as aluminum and vinyl siding negatively effect the integrity of a historic house and are therefore, not recommended.

Substitute siding materials are not entirely ‘maintenance-free’ as some of the product literature claims. Typically substitute materials cannot be painted or easily repaired in the future for paint has difficulty sticking to synthetic siding and it is not easy to replace just a few pieces of synthetic siding. Substitute siding also typically cannot achieve the trim detail that wood offers, making the house lose much of its architectural character.

Recommended:

- It is always advisable to paint, rather than replace wood with another material.
- Deteriorated siding or decorative elements should be patched or consolidated in place, or replaced with in-kind materials.

- When replacing materials, match the overall dimension, thickness, profile, scale and finish of the original fabric.
- Preparation of wood surfaces and proper priming will add longevity to paint applications. Do not paint over cracked or peeling paint.
- Utilize high quality exterior paint. Do not paint when it is too cold or too hot outside.
- Paint stripping should be done by the gentlest means possible.
- Choose a paint scheme appropriate for the time period in which the house was constructed and the architectural style. Design assistance can be provided by contacting the Planning and Zoning Department.
- Remove existing inappropriate siding that covers original, historic materials.



Example of cracked and peeling paint in need of repair. Loose paint should be carefully removed prior to priming and painting, Harrisburg, Missouri, 2008.

Not Recommended:

- Do not apply new paint to existing deteriorated paint that has cracked or has too many layers.
- Do not install aluminum, vinyl, or synthetic siding to cover original, historic siding or building elements.
- Do not remove character-defining elements from a house.

What is considered Maintenance and what requires a COA?**Maintenance:**

- Replacement of individual trim or a single siding board to match existing.
- Touch up painting of siding and trim with the same color it is currently painted.

COA:

- Replacement of more than a 20% of the siding or trim boards.
- New siding or trim installation (regardless of material).
- New paint color or all new paint color scheme.



Left: Example of a character defining exterior wood element that can be repaired and used for making replacement pieces, Kirksville, Missouri, date unknown.

References:

Preservation Brief 8: *Aluminum and Vinyl Siding on Historic Buildings: The Appropriateness of Substitute Materials for Resurfacing Historic Wood Frame Buildings*

Preservation Brief 10: *Exterior Paint Problems on Historic Woodwork*

Preservation Brief 11: *Rehabilitating Historic Storefronts*

Preservation Brief 16: *The Use of Substitute Materials on Historic Building Exteriors*



Example of historic siding, trim and wood detailing intact, 205 South Francis, 2014.

Substitute Materials

Synthetic siding refers to man-made products such as vinyl, aluminum, steel, fiberglass, wood composites, or cementitious products. Contemporary synthetic siding is often applied to update the look of “older” buildings as new trends and styles emerge. Throughout the early to mid-twentieth century, asbestos shingles were used to “upgrade” or “update” traditional wood siding. In the twenty-first century, cementitious composite products such as “Hardieboard” and “SmartSide” products serve as alternatives to traditional siding materials.

Synthetic siding offers an alternative to traditional wood siding or masonry but can radically alter the character of the building and can cause permanent damage to the original building materials if not properly installed. Once new siding is applied over the original cladding, it is difficult to assess ongoing maintenance and water infiltration issues. Care should be taken when concealing wood siding with synthetic siding materials as moisture may be trapped between the two and create an environment for mold growth and wood rot.

Other contemporary materials include PVC lumber such as the brand “Trex” for decks and other structures and “Azek” for decorative exterior elements such as porch railings, balusters and brackets. Removing a historic material and replacing it with a contemporary material is discouraged and will require a COA.



Images shown are for illustration purposes only. The City of Excelsior Springs does not endorse, promote or recommend any specific products or services and use of these products does not imply or guarantee Certificate of Appropriateness approval.

Recommended:

- It is always advisable to paint, rather than replace wood with another material.
- Deteriorated siding or decorative elements should be patched or consolidated in place, or replaced with in-kind materials.
- When replacing materials, match the overall dimension, thickness, profile, scale and finish of the original, historic material.

- Utilize high quality exterior paint.
- Choose a paint scheme appropriate for the time period in which the house was constructed and the architectural style. Design assistance can be provided by contacting the Planning and Zoning Department.
- Remove existing inappropriate siding that covers original, historic materials.

Not Recommended:

- Do not apply new paint to existing deteriorated paint that has cracked or has too many layers.
- Do not install aluminum, vinyl, or synthetic siding to cover original, historic siding or building elements.
- Do not remove character-defining elements from a house.

What is considered Maintenance and what requires a COA?

Maintenance:

- Touch up painting with the same color it is currently painted.

COA:

- New siding or trim installation (regardless of material).
- New exterior deck or porch (regardless of material).
- New paint color or all new paint color scheme.

References:

Preservation Brief 16: *The Use of Substitute Materials on Historic Building Exteriors*



Images shown are for illustration purposes only. The City of Excelsior Springs does not endorse, promote or recommend any specific products or services and use of these products does not imply or guarantee Certificate of Appropriateness approval.

Stucco

Stucco was applied to historic buildings, either at the time of construction or in later years. If the stucco is important to the historic character of the building (as it is in many residential applications), it is important to maintain the material as you would any other exterior cladding. If the stucco was added inappropriately and masks historic architectural features or was utilized to create architectural details that were not originally present, it is desired to carefully remove the stucco and expose the historic facade.

Recommended:

- Always remove loose stucco and repair damaged areas before painting. Patched areas should match original stucco as closely as possible in appearance and texture.
- Carefully remove stucco that was inappropriately applied to exterior facades that masks historic features of the building.
- Install only historically-appropriate authentic stucco.

Not Recommended:

- Do not remove stucco from a building that was installed to mask damaged masonry unless it is intended to restore the underlying masonry to its original appearance. Stucco on a secondary facade is an appropriate repair for severely deteriorated masonry.
- Do not stucco a building that has not been covered before.
- EFIS and other modern synthetic stucco systems are not preferred.

References:

Preservation Brief 22: *The Preservation and Repair of Historic Stucco*



Example of traditional stucco installed on a new garage addition.
Kansas City, MO, 2005.

What is considered Maintenance and what requires a COA?

Maintenance:

- Patching small holes or cracks in stucco. Be sure to perform this work when the weather is warm and will not go below freezing so the stucco is able to cure and dry.
- Touch up painting with the same color it is currently painted.

COA:

- Replacement or patching of more than a 20% of the stucco.
- New stucco installation (includes EFIS).
- New paint color or all new paint color scheme.

Concrete

Preserve concrete features of a building, such as steps, walkways, porches, foundations, chimneys and details, whenever possible. Concrete is often reinforced with metal rebar that corrodes over time due to water infiltration and the freeze/thaw cycle. Find the source of deterioration prior to patching concrete or replacing damaged components. Since water is often the source of concrete deterioration, provide proper slope for drainage so that water does not stand on concrete surfaces and drains away from concrete foundations. Sidewalks in front of your home are the homeowner's responsibility to maintain and replace if they become damaged (weather, freeze-thaw, tree roots, etc.). When time to replace, sidewalks need to be installed per the City's sidewalk ordinance and guidelines. Contact the Public Works Department for sidewalk information and guidance.

Recommended:

- Match repaired concrete to original concrete as closely as possible in color and texture.
- Find the source of deterioration (typically rusted reinforcement bar) and replace damaged parts.
- Provide proper slope for drainage so that water does not stand on concrete surfaces and drains away from concrete foundations.

Not Recommended:

- Do not patch concrete without addressing the source of deterioration.

References:

Preservation Brief 15: *The Preservation of Historic Concrete*

- Avoid using a patching material that does not match the original concrete. Make sure new concrete will bond properly with existing concrete in order to avoid water penetration and further damage.
- Do not paint concrete.
- Do not install modern synthetic stucco systems.

What is considered Maintenance and what requires a COA?

Maintenance:

- Patching small holes or cracks in concrete. Be sure to perform this work when the weather is warm or provide adequate cold weather blankets and covering when below freezing so concrete is able to cure and dry.

COA:

- New concrete installation including: steps, walkways, porches, foundations, chimneys and decorative building elements.



Left: Example of a decorative cast concrete baluster. The left baluster is historic and the right is a replacement. Kansas City, MO 2013.

Roofs, Gutters and Downspouts

Roofs are an important character-defining feature of the Boarding House Historic District. Roofs on residential buildings, often distinguish the particular style of the house. It is important to maintain the original shape, materials and features of the roof to retain the integrity of the building style.

It is often not financially feasible to re-roof using original materials such as clay tile or slate; however, it is important to use appropriate roofing materials. For example, a metal standing seam roof is not appropriate for a Prairie Style house, although a patterned asphalt shingle roof may be appropriate for a Queen Anne Style house.

The shape of the roof is also important to the design of the building. Slopes and overhangs should not be changed and details such as soffits, fascias and friezes should be maintained. Additionally, dormers should remain intact and in their original state. For example, combining two dormers (to enlarge an attic space) is not appropriate, as it changes the roof line of the house and causes a loss of architectural integrity.

Gutters should be maintained to prevent water damage to the structure. Hire qualified roofing contractors who understand how to work on historic structures, especially when installing factory-made or seamless gutters. Occasionally, gutters are an integral part of the roof while others are simply attached. Often, if the pitch of the roof is steep, factory made gutters do not have the capacity to catch the increased water flow.



Top: 223 South Francis, Bottom: 515 Benton Avenue. Examples unique roof shapes that are character defining features that should be retained. Excelsior Springs, MO 2014.

Roof Shape Terminology

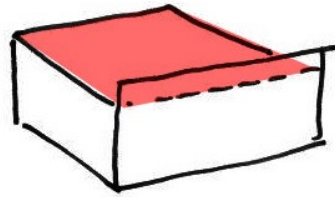

Flat Roof

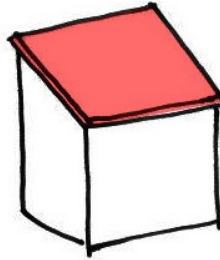

Shed Roof

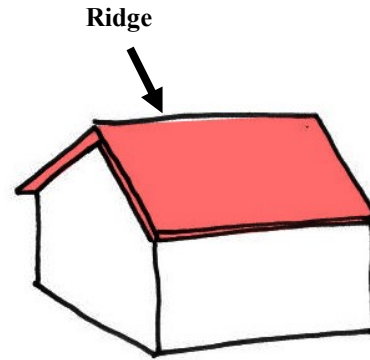

Gable Roof

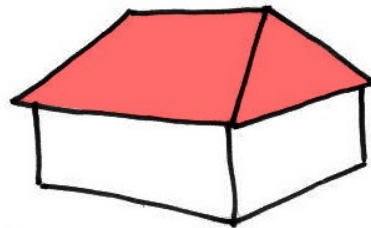

Hip Roof

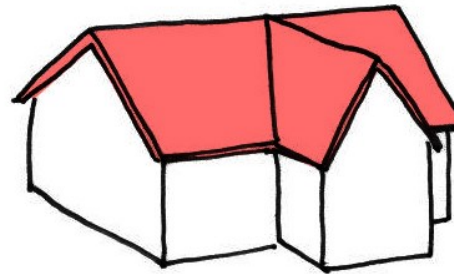

Cross-Gabled Roof

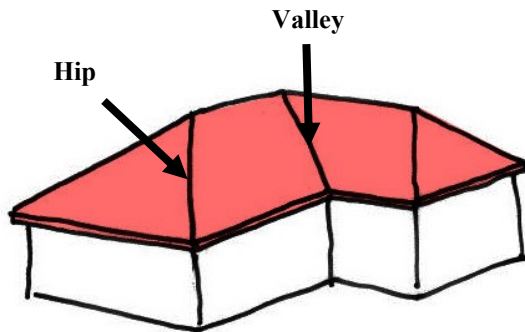

Cross-Hipped Roof

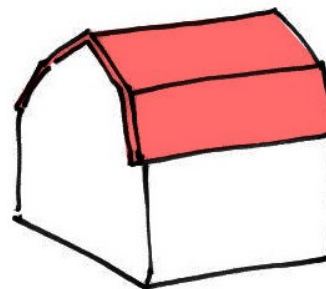

Gambrel Roof

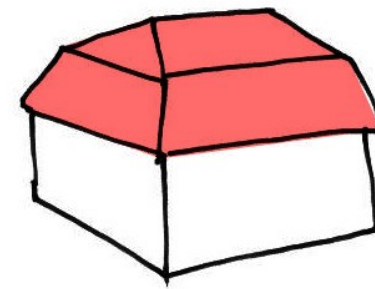

Mansard Roof

Graphic by Susan Richards Johnson & Associates, Inc. 2014.

Recommended:

- Maintain original shape, materials and features of roofs to maintain integrity of the structure.
- Use roofing materials that match the historic character of the building (size, scale, pattern, texture and color) when re-roofing.
- Maintain roof shapes, slopes and overhangs.
- Maintain gutters to prevent water damage.
- Use qualified subcontractors that understand how to work on historic buildings when installing new roofs on an historic structure.
- Paint new metal gutters and downspouts an appropriate color to match or compliment the building.



Example of roof flashing around a brick chimney, Howard County, Missouri, 2008.



Gabled Dormer

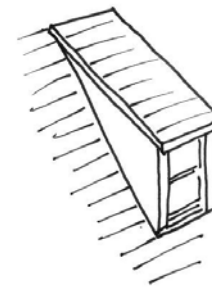

Shed Dormer

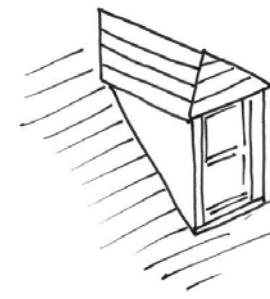

Hipped Dormer



Eyebrow Dormers

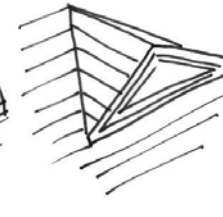

Segmental Dormer

Not Recommended:

- Do not change the original shape or features of the roof.
- New roofing materials are not required to match original materials; however, do not install new materials that are not appropriate to the building style.
- Do not change the original slope or overhang of the original roof.
- Do not change details such as soffits, fascias, friezes and dormers.
- Do not allow gutters to become clogged and overrun with debris and water, allowing water to run down the face of the building.
- Do not use unqualified roofing contractors.

- Do not paint new gutters and downspouts with a color that highlights the new system and is not complimentary to the building.
- Do not install gutters that do not have enough capacity for the water flow of steep roofs, especially those of the Victorian Period.
- Do not install obtrusive gutters that remove or cover character-defining elements.

What is considered Maintenance and what requires a COA?

Maintenance:

- Replacing individual roof shingles to match existing.
- Repairs and cleaning of gutters and downspouts.
- Repairs to flashings.

COA:

- New roofing installation (regardless of material).
- New gutters and downspout installation.
- New dormer installation.
- Changes that alter the appearance of the soffits, fascias, friezes and dormers.

References:

Preservation Brief 4: *Roofing for Historic Buildings*

Preservation Brief 16: *The Use of Substitute Materials on Historic Building Exteriors*

Preservation Brief 19: *The Repair and Replacement of Historic Wooden Shingle Roofs*

Preservation Brief 29: *The Repair, Replacement, and Maintenance of Historic Slate Roofs*

Preservation Brief 30: *The Preservation and Repair of Historic Clay Tile Roofs*



Example of different asphalt roof shingle styles. Top, typical 3-Tab shingles. Bottom, architectural style shingles cut in a pattern to resemble wood shake roofing.

(Image from <http://bradyroofing.com>)

Doors and Windows

Doors and windows are very important features of historic buildings and are one of the identifying features of a particular style. Their size, shape, style, placement, configuration and materials, including hardware, are all important aspects of doors and windows.

New doors, windows and hardware should match the original features they replace as closely as possible. New doors and windows should be appropriate to the style of the building. Elements of an opening, such as sidelights and transoms, should be maintained. Replacement doors and windows should not change the proportion or size of the original openings.

It is often less expensive to repair original doors and windows rather than to replace them in-kind. Original doors and windows were crafted with materials and detailing that are difficult to replace. Aluminum and vinyl windows often look out of place as replacements to historic windows. Wood windows and doors are easier to work with and are paintable in an array of color schemes. Additionally, replacement parts such as door knobs and hinges, and window counter weights and pulleys are readily available. Properly fitted and weather-stripped windows with storm windows are just as energy efficient as new insulated glass windows.

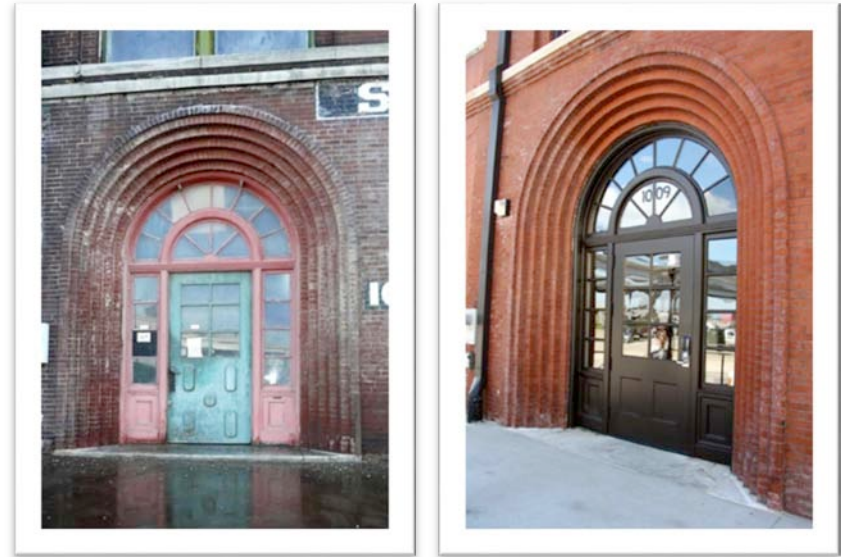

Left: Image of a deteriorated historic wood door with transom and sidelites. Right: Image of new replica aluminum door with transom and sidelites. The new door accurately recreates the look and feel of the original in a new material. Kansas City, MO 2009.

Recommended:

- Maintain and retain original doors and windows.
- When replacement is required, new doors and windows should match original features, size, shape, style, placement, configuration and materials (including hardware) of the original doors and windows.
- New doors and windows should be appropriate to the style of the building.
- Maintain sidelights and transoms.
- Storm doors and windows should be inconspicuous.

Window Terminology

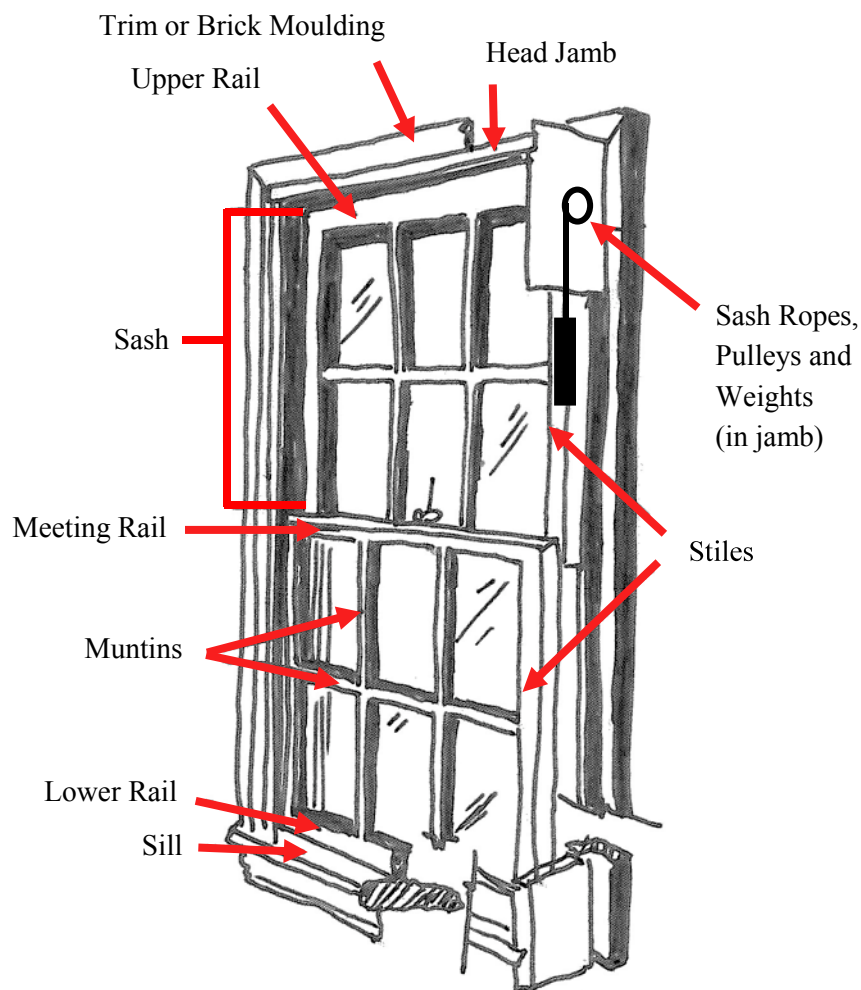

Graphic by Susan Richards Johnson & Associates, Inc. 2014.

Not Recommended:

- Do not replace original doors and windows unless they are deteriorated beyond repair. Replacement due to assumed energy inefficiencies should be avoided. A properly fitted and weather-stripped window or door with a storm window or door will be just as energy efficient as new units.
- Do not cover or infill transoms and sidelights.
- Do not increase or reduce the original opening size. (Do not install windows within an existing frame).
- Do not install new windows or doors that do not match the original lite configuration. For example, do not replace a multi-lite 6/6 double-hung wood window with a new vinyl casement window. Do not replace a single-lite wood door with a new solid hollow-metal door.
- Do not use highly reflective contemporary storm windows and/or storm door units.

What is considered Maintenance and what requires a COA?

Maintenance:

- Replacing broken glazing or reglazing with glazing putty.
- Restoration of existing doors and/or windows.
- Touch up painting with the same color it is currently painted.

COA:

- New windows and/or doors installation (regardless of material, location or number of windows or doors replaced or added)
- Changes that alter the appearance of the doors and windows.
- New paint color or all new paint color scheme.
- New storm windows, storm door or security door.

Window Types

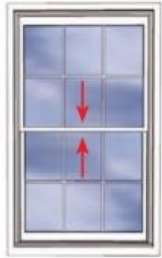

Double-Hung Window

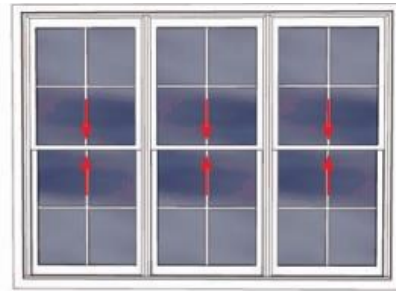

Mullied Double-Hung Window



Casement Window



Double Casement Window

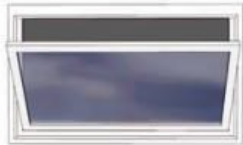

Hopper Window

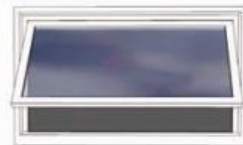

Awning Window



Picture Window



Fixed Window



Slider Window



Bay Window



Geometric or Specialty Window



Jalousie or Louvered Window

Graphic by Susan Richards Johnson & Associates, Inc. 2014.

Window and Door Styles

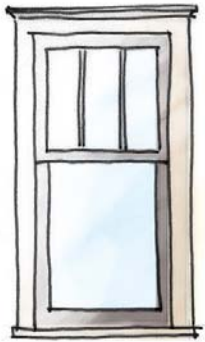

Craftsman Style Window

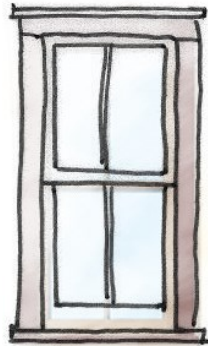

'Farmhouse' Style Windows and Door

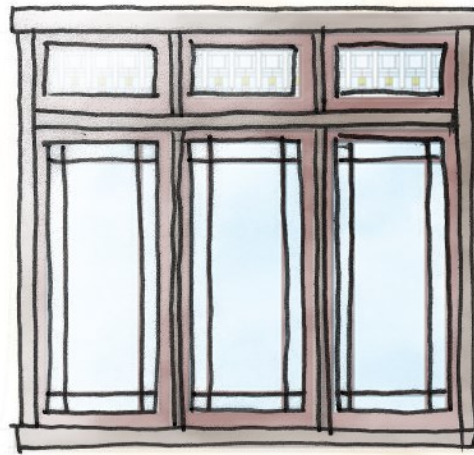
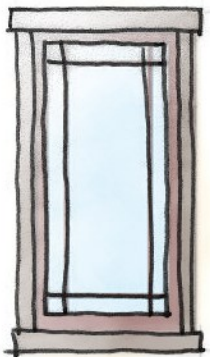

Prairie Style Windows and Door

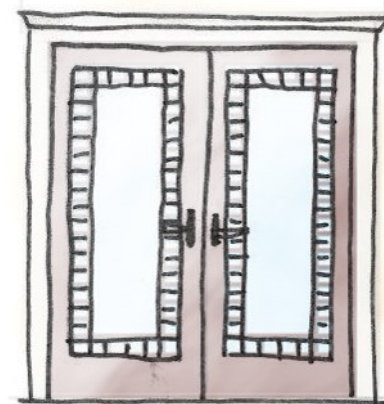
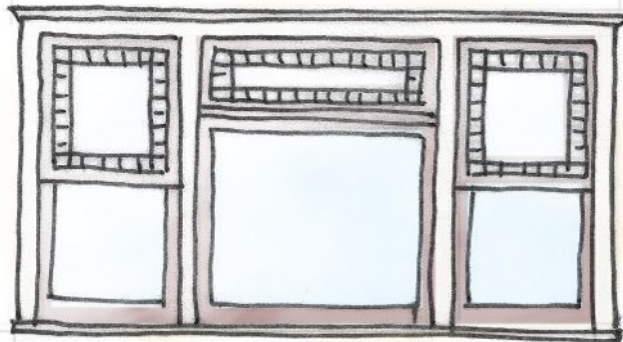
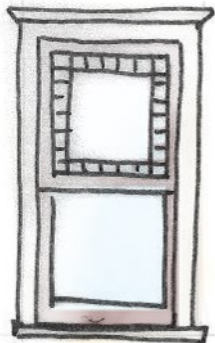
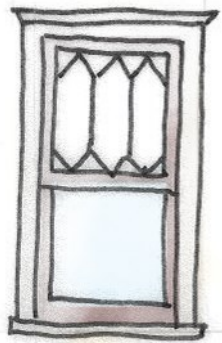

Victorian Style Windows and Doors

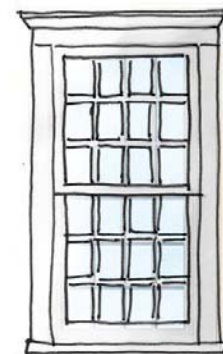
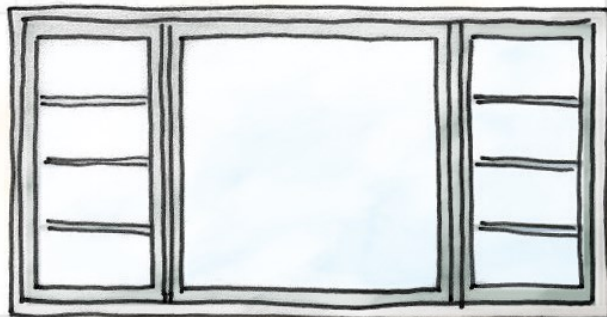
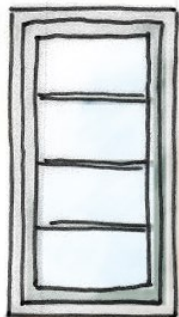

Minimal Traditional and Ranch Style Windows and Door

Georgian or Federal Style Window

References:

Preservation Brief 9: *The Repair of Historic Wooden Windows*

Preservation Brief 10: *Exterior Paint Problems on Historic Woodwork*

Preservation Brief 16: *The Use of Substitute Materials on Historic Building Exteriors*

Door Terminology

Paneled door with decorative stained glass



Transom Windows

Sidelight (or sidelite) Windows

Door Hardware

Decorative door trim and mouldings

Graphic by Susan Richards Johnson & Associates, Inc. 2014.

Porches, Decks, Balconies, Exterior Ramps and Stairs

Porches and balconies also help to define the style of a building. When a porch or balcony is removed or altered, not only the character of the building is changed, but the loss can greatly affect the rhythm and alignment of an entire block.

It is important to maintain and retain original porches, balconies and stairs and their elements. Regular maintenance of porches and balconies are necessary because they are exposed to weather and thus, are extremely vulnerable to the elements. If deterioration has occurred, replace heavily deteriorated wood elements in kind or repair wood elements with wood epoxy before painting. Do not alter character-defining elements, such as replacing turned spindles with straight spindles or replacing wood railings with decorative metal railings. These alterations drastically change the appearance of the building and results in the loss of architectural integrity.

The replacement of missing original porches and balconies is highly encouraged. Photographic, graphic or written documentation are helpful tools for reconstruction of such missing elements. If there is no documentation, construct a porch or balcony with design elements appropriate to the style and age of the building, and if appropriate, take cues from surrounding buildings of similar styles.



Example of a decorative front porch. The overall front porch configuration, materials and detailing (porch columns, brackets, railings and floor/ceiling) are all character defining features of this house. Without them, its historic character would be lost. 205 South Francis, 2014.

New Exterior Ramps, Decks and Stairs

The addition of a new exterior ADA ramp or exterior stair should be considered carefully. It is preferred that new exterior ramps, decks and stairs be located on the rear of a building, not visible from the public right of way. Materials and overall design/style for the new construction should carefully thought out and is recommended to resemble but not copy the historic building. All exterior ramps, decks, porches, balconies and stairs must be painted or stained, no bare wood. New exterior decks, ramps and stairs should be constructed in a way that is independently structured and reversible, meaning that in the future the exterior element could be removed with little or no damage to the historic building.

Recommended:

- Reconstruction of missing porches and balconies where photographic, graphic or written documentation exists is encouraged.
- Maintain and retain original porches and balconies and their elements.
- Replace wood or metal elements deteriorated beyond repair with in-kind materials.
- Repair deteriorated wood elements with wood epoxy prior to re-painting.

Not Recommended:

- Do not allow wood or metal porches and balconies to go without maintenance.
- Do not alter character-defining features of porches and balconies.
- Do not replace elements of porches and balconies with new elements that do not match the size, proportion or material of the original element.

What is considered Maintenance and what requires a COA?**Maintenance:**

- Replacing individual broken balusters to match existing.
- Touch up painting with the same color it is currently painted.

COA:

- New porches, decks, balconies or exterior ramp or stairs.
- Changes that alter the appearance of the porch, deck, balcony or exterior stairs.
- Demolition of any portion or complete demolition of a porch, deck, balcony or exterior ramp or stair.
- New paint color or all new paint color scheme.



Top: Example of an inappropriate infill of a front porch. Bottom: Example of an inappropriate exterior ramp installation on the front of a historic house. The ramp design dominates the first impression of the house and does not resemble the house's style, nor is it painted to match.

Architectural Metals

Architectural metals often are a character defining feature of a building. Cast iron, tin, copper and wrought iron were used for structural columns, decorative fencing, storefront windows, balconies and decorative architectural details such as cornices and bulkheads. It is important to maintain these details, as they are subject to damage caused by weather and neglect. The life of these details will be prolonged if they are kept painted and free from damage. Roof damage can affect these elements, especially cornices, by allowing water to penetrate the joints, leading to rust and deterioration of the concealed inside-facing surfaces. If metal features are damaged beyond repair, replace elements with new in-kind materials matching the original feature.

Recommended:

- Retain and maintain metal elements that contribute to the character of the building.
- Make certain that water is not standing on or behind these elements, causing them to rust or otherwise deteriorate. Sometimes roof or gutter damage can also damage these decorative elements.
- Properly prepare metals before painting. Remove all corrosion and repair any damage. Prime all surfaces with appropriate metal primer, if required, and follow paint manufacturers instructions.
- Repair metal features when possible, or replace materials in kind.

References:

Preservation Brief 27: *The Maintenance and Repair of Architectural Cast Iron*



Left: Original deteriorated architectural cornice. Right: Replicated architectural cornice. New metal cornice has structural supports and is made of the same lead coated copper as the original, Rockport, Missouri, 2009.

Not Recommended:

- Do not remove or alter original metal features of the building.
- Do not replace historic metal with new “updated” replacement materials.
- Avoid leaving metal details exposed if they were originally intended to be painted. Do not use cleaning agents that will harm the finish on the metal, whether it is a natural patina, paint or sealant. It is typically not recommended to remove patina from metal, as it may be protecting the metal from weather damage.
- Do not replace a feature if it can be repaired.
- Avoid creating a false historical sense by adding embellishment to a building when it had none before.
- Do not add features that are not appropriate for the style of the building or are incompatible in size, scale, material and color.

Mechanical Equipment

Mechanical equipment, such as television antennas, solar panels and telephone wires, are a necessary part of a building and city infrastructure. These items should be installed at the rear of a building in an inconspicuous place. Landscaping and fencing may be used to shield these elements but this should be done in a reserved manner. Additionally, these elements should not cause permanent damage to the building. Portable window air conditioners are considered temporary, and will be allowed on the front facade of a building during warm weather. They should be removed when not in use.

Recommended:

- Minimize the visual impact of mechanical and electrical equipment.
- Utilize lattice panels and planting to screen utilities, as appropriate for the building type and period of construction.
- Screen utility connections and boxes such as telephone, gas meters, A/C condensers and cable boxes.
- Locate service and mechanical equipment and standpipes on non-primary facades so that they will not impact the historic primary façade materials.
- Mechanical units can be installed on roofs of apartment building if held back from the building edge (parapet) and is not visible from the public right of way.



Example of a mechanical unit inappropriately located on the primary façade, 339 East Broadway, 2014.

Not Recommended:

- Do not install through-wall air-conditioning units on the building.
- Do not cut channels into or remove historic façade materials to install utility lines or mechanical equipment including exhaust hood fans, dryer vents, etc.
- Do not locate utility lines or utility boxes on the front façade of a building or in the front yard of a residence.

What is considered Maintenance and what requires a COA?

Maintenance:

- Repairing existing equipment.

COA:

- New exterior A/C condensers and any other equipment (includes TV antennas and satellite dishes).

Awnings

Awnings can be an attractive element in a streetscape when they are made of an appropriate material, color and design. They provide shade, shelter and a point of reference. Additionally, awnings can create continuity in a streetscape as well as a sense of human scale. In some cases, awnings can mask inappropriate alterations made to a building. Precedence of awnings in Excelsior Springs can be seen in historic photos of the district.

Recommended:

- Choose an awning design that is appropriate to the scale of the building. An awning that is too large or small will not look like an integrated part of the building. Finally, the shape of the awning should be simple enough to not detract from the building. A sloped awning is typically most appropriate.
- Install the awning in a manner that does not damage or hide the architectural character of the building.
- Maintenance of the awnings are important. Replace broken, torn or damaged awnings and touch up paint as required.

Not Recommended:

- Do not use a color scheme that is incompatible with the building. Also, do not use too many colors.
- Do not install awnings if they are not needed. Typically awnings are not needed on north elevations.
- Do not install awnings in an irreversible way which permanently damages the exterior siding or window.



Example of painted metal awnings in good condition, 109 Saratoga, 2014.

What is considered Maintenance and what requires a COA?

Maintenance:

- Repairing existing awning structure or fabric/covering (not changing its appearance)

COA:

- New awning installation.
- Changes that alter the appearance of the awing including, but not limited to: color, shape or signage installation.

Lighting

Although most streetscapes in commercial districts are lit by street lamps, it is often desirable to provide additional lighting. Wall or ceiling-mounted light fixtures at a recessed entrance are appropriate for providing additional lighting at entrances. To light a secondary entrance to an upper level, a single wall-mounted fixture placed above the door is appropriate. If the fixture is too large and noticeable, the fixture should have some historic precedent.

Recommended:

- Choose a fixture that is appropriate for the building age. A carriage lamp, for example, on a 1930s building is inappropriate.
- Make sure the fixture is an appropriate scale for the building. Do not place a very large fixture next to a secondary entrance or a very small, residential type fixture next to a storefront.
- The most appropriate place for entry lighting is on the ceiling of the entry vestibule. A simple ceiling mounted or pendant fixture is most appropriate.

Not Recommended:

- Do not permanently remove or alter original lighting fixtures. Do not replace historic fixtures with new “updated” fixtures.
- Do not place a lighting fixture in an inappropriate place. Be aware of ADA regulations for lighting dimensions and placement.
- Avoid fixtures that can easily be damaged or become dangerous if broken.

What is considered Maintenance and what requires a COA?

Maintenance:

- Repairing existing light fixtures (regardless of location).

COA:

- New exterior lighting (includes pole mounted and building mounted light fixtures).

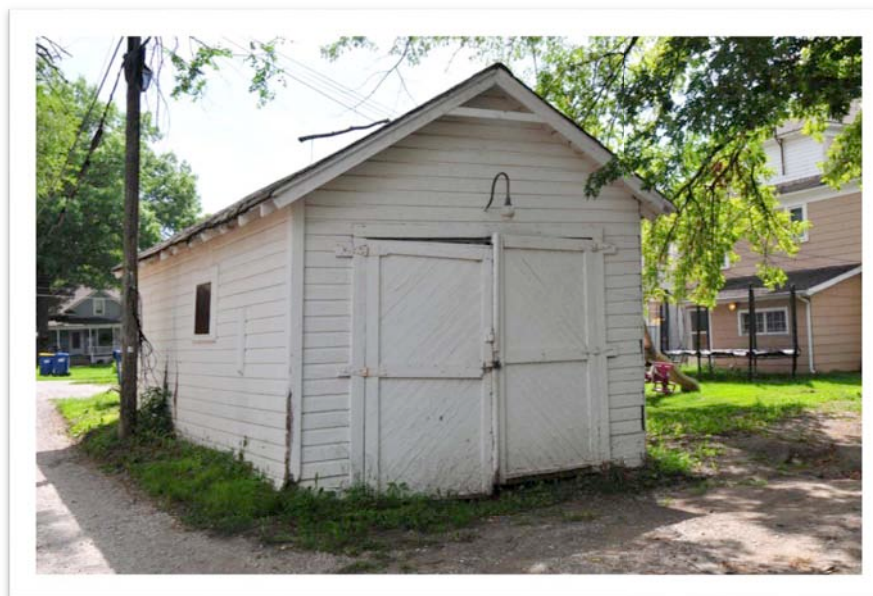

Example of a historic light fixture on a historic outbuilding. Historic light fixtures are encouraged to be restored, 518 Isley Boulevard, 2014.

Sitework

Sitework must also be reviewed when rehabilitating or modifying properties in the Boarding House Historic District. Sitework is an important character-defining feature of the historic district and aids in defining the overall characteristic of the district as a cohesive whole.

Excelsior Springs's sitework is especially important as it relates to its historic parks and boulevard system, which is an elaborate system unusual for a town the size of Excelsior Springs. Due to the town's development as a resort and leisure destination, it gained the attention of regionally renowned landscape architect and city planner, George Kessler, who designed much of Excelsior Springs' parks and boulevard system. For more information regarding the history of Excelsior Springs' parks and boulevard system:

www.esparks.org/history.html

www.theidlehour.com

The sitework discussed in this section include:

Retaining Walls

Fences and Railings

Alleyways or Rear Facades

Landscaping



Top: 103 Temple. Bottom: 434 East Excelsior. Examples of different types of site walls and stone patterns. Some walls are retaining walls and others are free standing walls. Excelsior Springs, MO 2014.

Retaining Walls

Stone retaining walls are common in Excelsior Springs. They often help define the set back of a property, offering a visual alignment along a street. Proper care and maintenance is required in order for a retaining wall to endure the harsh elements of the Midwest climate. There are two types of retaining walls, those built with mortar and those built without mortar (drystone). Walls with mortar must be maintained and repointed as needed in order to keep from bulging and eventually collapsing. Drystone walls must be checked regularly for stability, as they may need to be re-stacked.

Recommended:

- New retaining walls should be designed to match the style of the house and the existing retaining walls on-site and/or within the historic district.
- New retaining walls should be constructed of materials that match those of the building.
- Pay attention to details such as stone type, pattern (coursed, random, ashlar, etc.) and joint types (flush, recessed, grapevine, etc.). This helps the wall look more compatible with the historic building and site.

Not Recommended:

- New retaining walls should not differ from the visual line and setbacks of the historic streetscape.
- New retaining walls should not be made of materials such as wood planks, chain link metal, split-face pavers or concrete masonry units.

What is considered Maintenance and what requires a COA?

Maintenance:

- Repairing existing retaining walls to match existing.

COA:

- Replacement of sections of retaining walls.
- New retaining walls (regardless of material).
- Changes that alter the appearance of the retaining wall.
- Demolition of any portion or complete demolition of a retaining wall.



Example of a rustic dry laid stone retaining wall. Grade elevation varies greatly throughout the Boarding House District with many houses set on steep hills, 512 East Excelsior, 2014.

Fences and Railings

Fences have been common throughout history for both ornamentation and privacy. Privacy fences are more opaque and usually constructed of wood. A common construction method for a privacy fence is a vertical board fence; however, it is important to make sure that fences match the architectural style of the building. Ornamental fences offer several options. Picket fences are most common because they are appropriate for a wide variety of building types and are more cost effective than their wrought iron counterparts. Ornamental fences should be short enough to not distract from the architecture of the building.

Retain and preserve existing fences that contribute to the historic character of a property. Maintain and repair, through appropriate methods, the defining features of historic fencing including: material, height, configuration, ornamentation, and functional design.

Privacy fences at the rear of the property should be painted or stained an opaque finish. Historically these fences were never left to weather naturally, nor were they sealed only with a clear wood finish. When reconstructing a historic fence, the new construction should be based on existing and historic documentation of the original that identifies the defining features including: material, height, scale, configuration, ornament and detail.

The introduction of new fences should be limited to those areas of the property that are not readily visible from the public right-of-way. Modern fences should be located in a way that complements the historic boundaries

of the property without concealing its character defining features. Modern fences should also not attempt to look historic. Instead, these features should strive to enhance the character of the property and be constructed of an appropriate material, scale, height, and configuration.



Top: Example of a wood railing in good condition, 512 Isley Boulevard, 2014. Bottom: Example of a house with its historic railing removed and an incomplete railing installed, 103 North Francis, 2014.

Recommended:

- Privacy fences should be painted or stained an opaque finish. Historically they were never left to weather naturally and were never stained a natural wood finish.
- Ornamental fences should be 2 1/2 feet high or less, so as not to distract from the architectural elements of the building.
- For picket fences, the pickets should be placed no more than 3 1/2 inches apart for the best visual effect.
- Ornamental shrubs may also be used as a fence when planted in tight rows. It is essential that the shrubs are pruned correctly and kept neat, in order to clearly define the building's property line.

Not Recommended:

- Fencing types that are not appropriate are metal chain link fences and more modern looking fences such as basket weave, stockade, split rail and board-on-board designs. These styles are not compatible with historic buildings.
- Fencing other than ornamental style fencing in front yards will be discouraged.

References:

Preservation Brief 10: *Exterior Paint Problems on Historic Woodwork*

Preservation Brief 27: *The Maintenance and Repair of Architectural Cast Iron*

What is considered Maintenance and what requires a COA?**Maintenance:**

- Repairing existing fencing or railings to match existing.

COA:

- Replacement of sections of fences.
- New fences or railings (regardless of material).
- Changes that alter the appearance of fences or railings.
- Demolition of any portion or complete demolition of a fence or railing.
- New paint color or all new paint color scheme.



Example of fencing in need of repair. Missing or broken fencing should be replaced to match the existing fence in-kind. All fencing should be painted or stained with a solid stain.

Alleyways or Rear Facades

Alleyways, or rear facades, are typically considered to be secondary facades and were not historically intended to be seen by the public. The rear facades were much more utilitarian and the general rules of alignment and pattern did not apply. Rear facades, even though they are not entirely visible from the public right of way, are important and improvements to these elevations will need to be reviewed by City Staff and/or the Historic Preservation Commission.

Rear facades are typically locations for the utilities into buildings and for outbuildings or garages. Excelsior Springs has many alley roads that align with rear facades of buildings that are used by residents for access to garages and for services such as trash removal. It is therefore, necessary to maintain these facades. Use discretion when placing trash receptacles, exhaust fans and utility locations as there may be additional set backs or easements that must be maintained. Additionally, make sure to maintain the appearance of a safe and attractive environment, and continue the use of appropriate building materials.



Example of a garage located off of an alleyway and view of the rear yard, 434 Benton Avenue, 2014.

Landscaping

Landscaping in residential neighborhoods is often an important feature and positively enhances the ‘curb appeal’ of a home. Landscaping can also provide shade which reduces summer heat-gain through windows, can help block winter wind, reduces air pollution, and creates a more pedestrian scale to the area. Landscaping also aids in the transition of vacant lots adjacent to buildings because of the visual continuity it provides. Street trees are the most common in the ‘parking’ area between the roadway and sidewalks in front of a property.

Recommended:

- Landscape vacant lots. Trees, shrubs and other plantings can provide a “soft edge” to a vacant lot when placed in line with setbacks and configurations of other buildings on the block.
- Street trees planted at the edge of the sidewalk create a buffer zone between cars and pedestrians. It also provides shade, shelter and a visual link throughout the streetscape.

Not Recommended:

- Do not use chain link fences, wood fences, tall shrubs or other devices / plantings that close off, obstruct or block views to the front a property.
- Do not introduce a landscape plantings that do not correspond with other landscaping in the district or that does not follow setbacks and alignment.
- Non-indigenous plantings are discouraged.
- Do not let plantings or weeds grow ‘wild’ or out of control.
- Invasive species of plantings are prohibited.

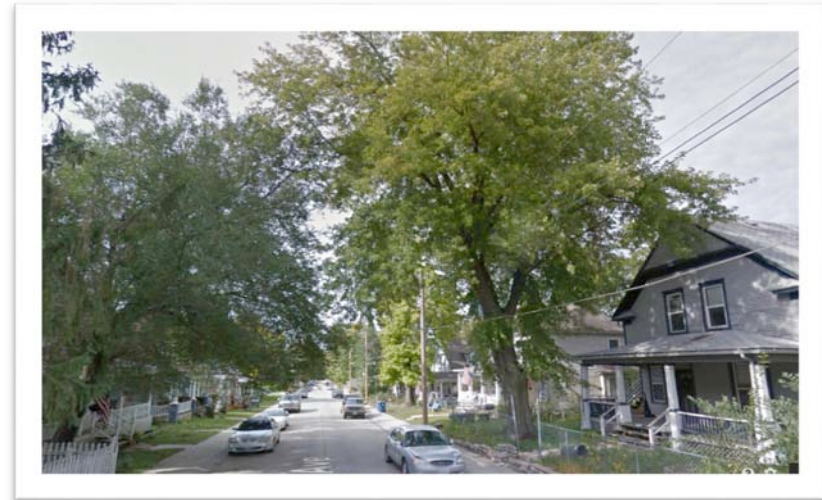

Street view on Benton Avenue, Excelsior Springs, MO 2014.

What is considered Maintenance and what requires a COA?

Maintenance:

- General upkeep of landscaping (mowing, pruning, trimming, etc.).

COA:

- Removal of large trees.
- Regrading or infill of the land.
- New fountains, pools or other permanent installations (if visible from the public-right-of-way).

References:

Preservation Brief 36: *Protecting Cultural Landscapes: Planning, Treatment and Management of Historic Landscapes*

Sustainability

‘The greenest building is the one that’s already built’ is a commonly quoted phrase that exemplifies the link between preservation and sustainability. Historic buildings are inherently sustainable for they were often designed and built using sustainable principles. They were typically constructed with materials produced locally, and were positioned on a site to take advantage of natural light, passive heating and cooling methods, natural ventilation, and landscape plantings. These same design and construction principles are encouraged today for new construction to create sustainable or ‘green’ buildings and environments.

The preservation of existing buildings is environmentally friendly because it uses fewer new resources, and diverts waste from local landfills. Buildings rehabilitated or adapted to new uses help to curb the need to build on undeveloped land or farmland. Materials salvaged and re-used are diverted from the landfill. Some old materials can be recycled into new products.

When a historic property is demolished, aside from a social/cultural loss, the majority of the embodied energy of the building is also lost. According to an article found within a bulletin published by the Association for Preservation Technology (APT), embodied energy is defined by sustainability experts as “the sum of the energy required to extract raw materials, manufacture, transport and install building products” (Sedovic, Walter and Gotthelf, Jill H. “What Replacement Windows Can’t Replace: The Real Cost of Removing Historic Windows,” 2005).



©iStockphoto.com/ChrisSteer

Preservation and re-use of existing buildings contributes to the local economy by utilizing local labor, generating revenue from the purchase of materials from local businesses, and increasing property values. Sustainability and historic preservation positively impact our society through the protection of cultural and natural resources and our identity within the community. It also encourages the retention of community connections through livable, walkable neighborhoods, and the retention of unique character defining architecture.

References:

National Park Service Sustainability Guidelines: Sustainability and Energy Efficiency in Historic Buildings; Weatherizing and Improving the Energy Efficiency of Historic Buildings.

<http://www.nps.gov/tps/sustainability.htm>



©iStockphoto.com/wyndy25

Research and care should be taken when introducing new ‘green’ technologies to historic buildings, ‘New does not always mean better’. The long-term effects of these products on the historic building should be taken into consideration including: the product’s design, material, installation method, proposed location and life-cycle cost. Another thing to consider is if the product or technology is reversible, meaning can it be easily removed with little or no damage to the property. If the ‘green’ technology or product has a good life-cycle, can be removed, has a good

return on investment, and does not negatively effect the historic nature of the property, it may be considered to be a good solution.

Solar Panels

Installing solar panels on your home is a big investment and proper planning to determine the most appropriate solar panel type, location, how much energy they will provide and what the pay-back time will be to recoup the costs of installation is extremely important to consider prior to installation. When installing solar panels on a historic home, the character defining features need to be preserved and not covered over, obscured or removed. All solar panel installations should conform to the Secretary of the Interior’s

Standards for Rehabilitation. All solar panel installations will be considered on a case-by-case basis and will require a Certificate of Appropriateness.

Detached solar arrays should be installed to the rear of the property, minimizing the visibility from the public right of way. It is recommended to screen the installations with plants or other vegetation that is suitable for the historic district. Solar panels installed on an existing historic house or new construction should be located on the rear side of the house or in other locations where they are not visible from the public right of way and should be installed in such a way that is reversible so that the solar panels could be removed in the future without damaging the house or its historic integrity of. Solar panels should not alter the slope of the roof and mounting should be flat with the roof slope. Panels and mounting should be compatible in color to the roof materials and be as unobtrusive as

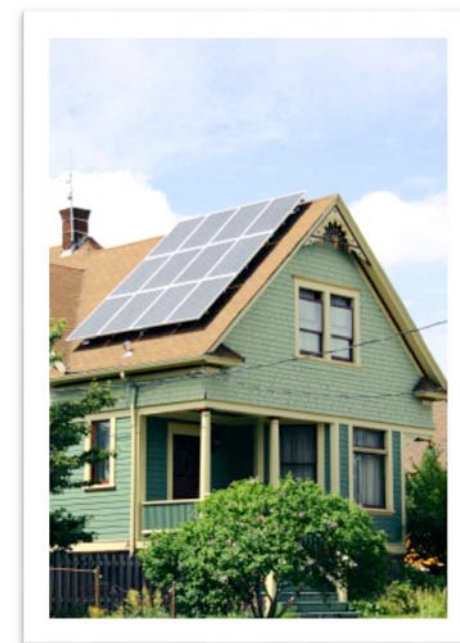

Not Recommended: Example of a historic house with solar panels installed on the primary, front elevation. ©iStockphoto.com

possible. Installation of solar panels on walls, siding or shutters should be installed on the rear of the building, minimizing the visibility from the public right of way. For additional information regarding solar panels and solar panel installation refer to the following article by the National Alliance of Preservation Commissions “Sample Guidelines for Solar Panels in Historic Districts” written by Kimberley Kooles, 2009. The information can be found on the National Trust for Historic Preservation’s website:

<http://www.preservationnation.org/information-center/sustainable-communities/buildings/solar-panels/additional-resources/NAPC-Solar-Panel-Guidelines.pdf>

Recommended:

- Locate stainable equipment installed on the exterior of the house on the rear or side elevations, not visible from the public right of way. This includes attached and detached equipment.
- Install sustainable equipment in a way that can be removed in the future without causing permanent damage to the exterior of the building.

Not Recommended:

- Installing solar panels and other sustainable equipment on the primary, front façade, or on an elevation that is visible from the street. This included attached and detached equipment (for example, detached solar arrays on grade).
- Installation of equipment that changes the overall appearance of the house.
- Installation of equipment that permanently alters the structure in any way.

- It is not recommended to install a skylight or solar tube on the primary façade.
- Green roofs are not recommended on sloped roof and thus would be inappropriate on residential structures.

What is considered Maintenance and what requires a COA?

Maintenance:

- General upkeep of the home (caulking around doors and windows, any interior installation, insulating, reglazing and painting windows the same color, upkeep of landscaping,).
- Installation of rain barrels, chimney flue balloons, compost bins and clothes lines. (These items are encouraged to be installed on the rear of the property.

COA:

- Storm windows and doors.
- Solar panels, evacuated tubes, wind turbines and solar exterior lighting.
- Skylights and solar tubes.
- Retrofitting existing windows with double pane glazing.
- Demolition of any portion of a property.
- Installation of new siding.
- New paint color or all new paint color scheme.
- Geothermal heating system wells.
- Green roofs.

Examples of ‘Green’ Technology

Historic window and door repair/restoration

- Weatherstripping
- Caulking/sealing air leaks
- New glazing compound

Re-glazing existing windows

Storm windows and doors

Clotheslines

Roof ridge vents

Rain barrels and water collection systems

Air sealing wall joints (sill plates), wiring, plumbing, chimney, and fixture penetration

Cotton batt or cellulose insulation for all easily-accessible, unconditioned spaces

Attic door blankets

Seal all air ducts with professional-grade duct tape or mastic

Foam gaskets behind outlets and switchplates

Compost bins

New mechanical systems such as high-efficiency furnaces, ground source systems, or solar air-heat panel systems

Solar light tubes/skylights

Solar-powered attic fans

Biomass pellet heating stoves

Dual flush toilets

Energy Star-rated appliances

Wind turbines

Solar panels

Retrofit existing windows with double pane glass

Composite siding (new construction and additions only)

Solar water heaters or tankless water heaters

Green roofs with native plant materials for flat roofs

Geothermal heating and cooling systems



Top: ©iStockphoto.com/Elenathewise
Bottom: ©iStockphoto.com/Ralph125

Energy Efficiency in Historic Buildings - Addressing the Building Envelope

Ten Tips for Sealing Air Leaks

The following information is from the U.S. Department of Energy:

Q: How Does the Air Escape?

A: Air infiltrates into and out of a building through every hole and tiny crack. About one-third of air infiltrates through openings in ceilings, walls, and floors.

1. First, test your home for air tightness. On a windy day, carefully hold a lit incense stick or a smoke pen next to your windows, doors, electrical boxes, plumbing fixtures, electrical outlets, ceiling fixtures, attic hatches, and other locations where there is a possible air path to the outside. If the smoke stream travels horizontally, you have located an air leak that may need caulking, sealing, or weatherstripping.
2. Caulk and weatherstrip doors and windows that leak air.
3. Caulk and seal air leaks where plumbing, ducting, or electrical wiring penetrates through walls, floors, ceilings, and soffits over door and window frames.
4. Install foam gaskets behind outlet and switch plates on walls.
5. Look for dirty spots in insulation, which often indicate holes where air leaks into and out of the house. Seal holes in inconspicuous areas with low-expansion spray foam.
6. Install storm windows over single-pane windows.



Top: ©iStockphoto.com/dlewis33

Bottom: ©iStockphoto.com/Oktay Ortakcioglu

7. Chimneys are a major source of air leakage. When the fireplace is not in use, keep the flue damper tightly closed. Install an inflatable chimney balloon to help seal the flue during seasons when the chimney is not in use. The balloons are made from several layers of durable plastic and can be removed easily and re-used for years. For safety, if the balloon should accidentally be left in place when a fire is started, the balloon will automatically deflate within seconds of coming into contact with heat.

8. Kitchen exhaust fan covers can keep air from leaking in when the exhaust fan is not in use. The covers typically attach using magnets for ease of replacement.

9. Replacing existing door sweeps and thresholds with ones that have pliable sealing gaskets is a great way to eliminate conditioned air from leaking out from underneath the doors. Take caution not to damage historic doors.

10. Fireplace flues are made from metal. Over time, repeated heating and cooling can cause the metal to warp or break, creating a channel for hot or cold air loss. Inflatable chimney balloons are designed to fit beneath your fireplace flue during periods of non-use.

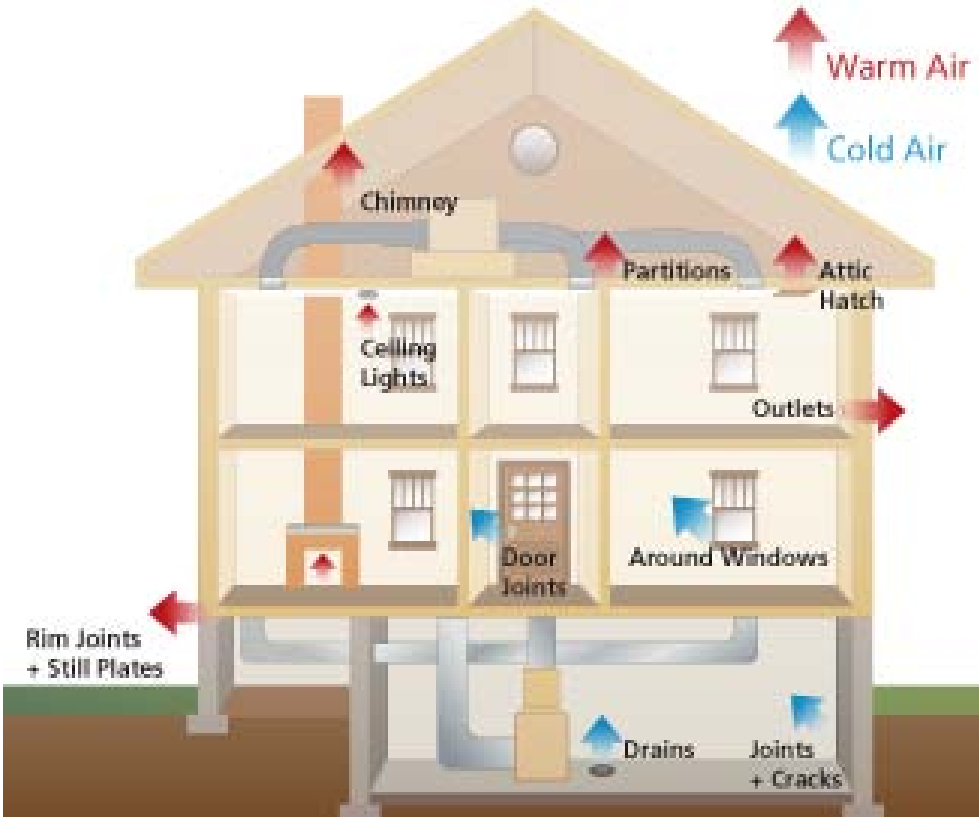

Left: Common Air Leaks. Air infiltrates into and out of a home through every hole and crack. About one-third of this air infiltrates through openings in ceilings, walls, and floors.
 Image courtesy of the National Park Service, Weatherizing and Improving the Energy Efficiency of Historic Buildings
 (www.nps.gov/tps/sustainability/energy-efficiency/weatherization.htm)

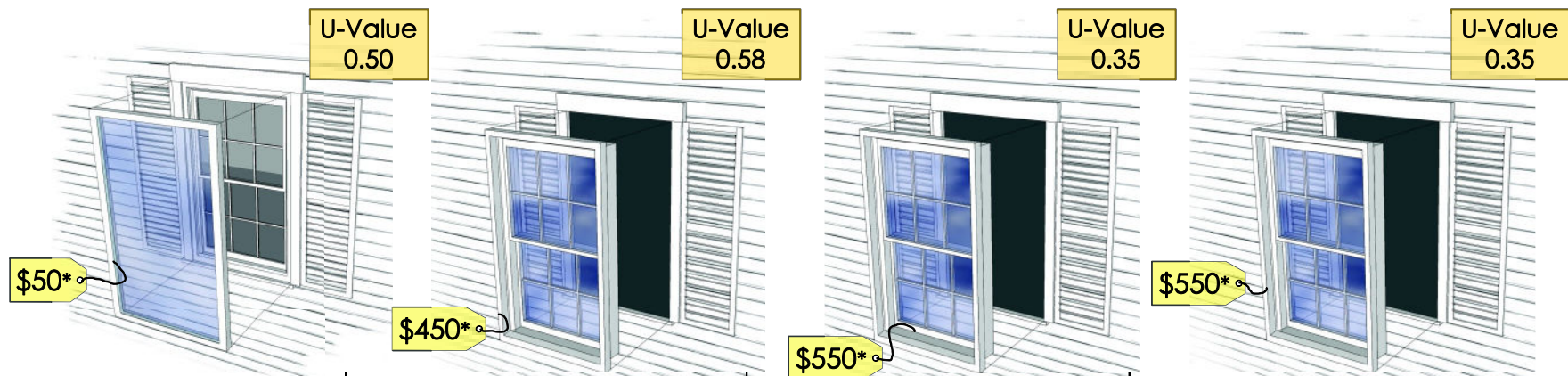

Storm window over single-pane original window

Double-pane thermal replacement of single-pane window

Low-e glass double-pane thermal replacement of single-pane window

Low-e glass double-pane thermal replacement of single-pane window with storm window



Original window in landfill forever



Original window in landfill forever



Original window and storm in landfill forever

Annual Energy Savings	722,218 Btu	625,922 Btu	902,772 Btu	132,407 Btu
Annual Savings per Window**	\$13.20	\$11.07	\$16.10	\$2.29
Simple Payback	4.5 Years ↑	40.5 Years ↑	34 Years ↑	240 Years ↑

All figures based upon article by: Lord, Noelle. "Embracing Energy Efficiency." Old-House Journal Sept. 2007: 40-45. Print.

*Estimated cost of Average 3'x5' window, installed by a professional (discount per unit may apply for whole house)

**Assuming gas heat at \$1.09/therm

Graphic by Susan Richards Johnson & Associates, Inc., 2011

6

DESIGN GUIDELINES FOR NEW CONSTRUCTION

Introduction

The design of buildings is based on the creation and organization of formal elements into a work of architecture. Mass, alignment, pattern, proportion, and material and color selections are all elements in building design. Building placement in relation to the street, building height and layout, entrance and window locations, porches, balconies, building materials and details are integral to architectural design.

Mass

Mass is the relationship between size and form. Height, width and depth all contribute to the volume of a building, which, in combination with form, creates mass. By creating a sense of coherency, mass plays an important role in the streetscape of a neighborhood. The buildings in the Boarding House Historic District are similar in mass, which make them relate to each other. A building with volume and form that does not relate to its surroundings distracts from the streetscape, creating a rift in the streetscape.

Alignment

Alignment is the arrangement in or adjustment to a straight line. Alignment of buildings along a streetscape is typically created by required setbacks. Alignment can also occur vertically by aligning roof lines, building heights, window heights and floor lines. Residential buildings have a greater setback requirement, determined by the zoning requirements in their respective neighborhoods. A building that does not align with its neighboring buildings stands out and breaks the coherency of the streetscape.

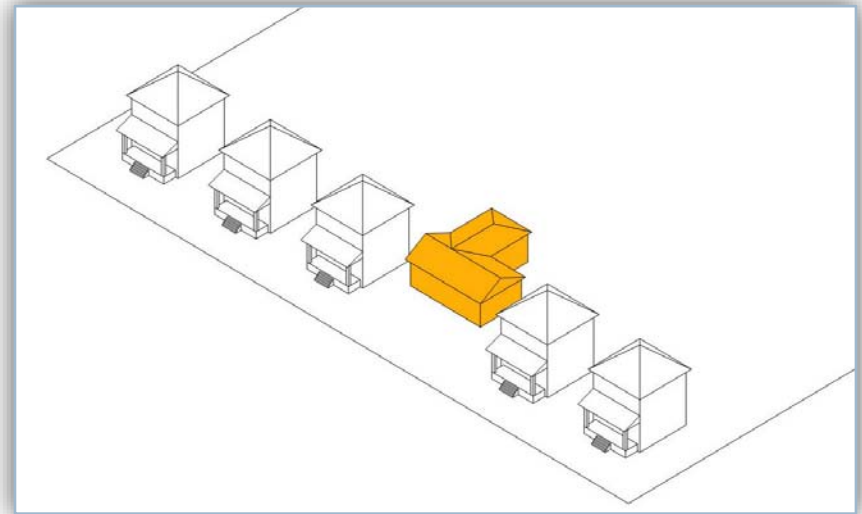

Example of incompatible residential infill construction that does not align with surrounding homes and interrupts the repetitive nature of the front porches, SRJA, 2014.

The glossary of the elements of design in this section is derived from Francis D.K. Ching's "A Visual Dictionary of Architecture," published by John Wiley & Sons, Inc., copyright 1995. Additional design glossary terms are listed in Appendix A.

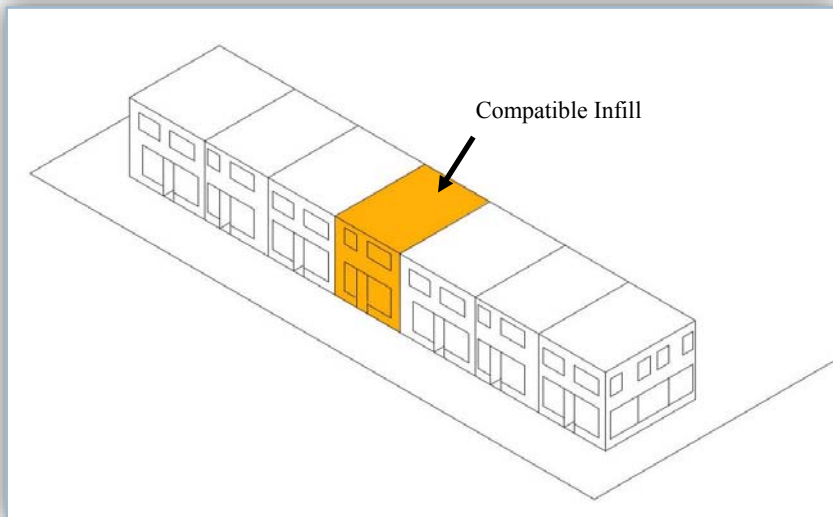
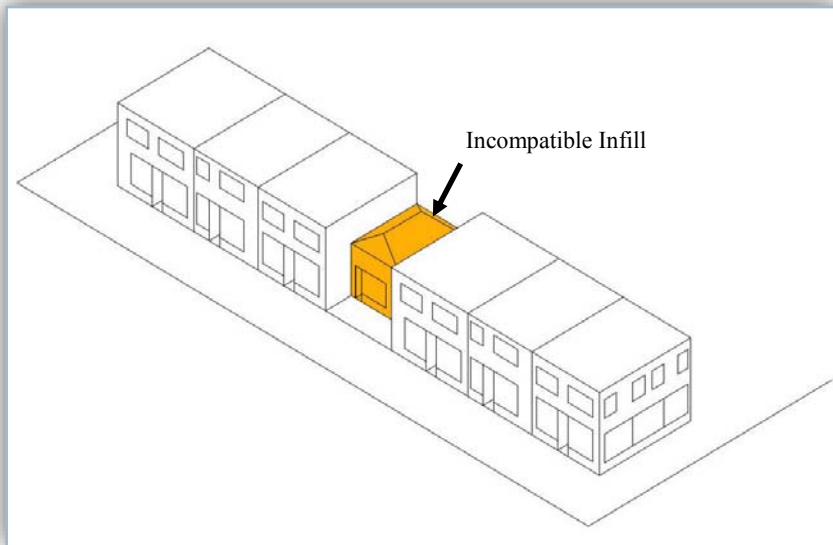

Pattern

Pattern is a decorative design having a characteristic arrangement and considered a unit. Pattern often includes a repetition of elements or form in a regular manner. Patterns can be found in individual building elements such as windows or in groupings of buildings with similar elements situated along a street. A building that breaks the pattern of a streetscape tends to look out of place and breaks the coherency of the streetscape.

Proportion

Proportion is the comparative, proper or harmonious relationship of one part to another or to the whole with respect to magnitude, quantity or degree. Building proportion is the harmonious relationship between the dimensions of one building object or building to another. This relationship may be between windows or porches and the whole of the building, or one entire building's relationship to another building. If the elements of the building are too large or too small in relationship to the whole building or to another object, that element is said to be "out of scale".

Top Left: Examples of incompatible commercial infill construction. The example of the incompatible commercial infill shows a new building with massing and proportion that does not relate to the volumes of the surrounding buildings. This is due to its setback and resulting reduced depth, its shorter height and hipped roof line, SRJA 2014.

Bottom Right: The example of the compatible commercial infill matches the surrounding buildings in mass, proportion, pattern and scale, height and flat roof, SRJA, 2014.

Materials and Colors

Materials in the Boarding House Historic District differ between commercial and residential areas. The commercial buildings are typically brick or stone with metal, wood or masonry trim. Materials for the residential areas of the district are typically wood frame with wood siding, brick or stone with wood windows and asphalt shingle roofs. The consistency and repetition of building materials of the district form a cohesive environment.

The color schemes of the Boarding House Historic District vary greatly depending on the style of house from the brightly colored Victorians to the earth-toned Craftsman and Prairie Style homes. When choosing a new colors for your historic house, consider choosing historically appropriate colors. Historic color scheme inspiration can be found though the following resources: the National Trust Historic Colors paint chips at your local hardware store, through the major paint manufacturer’s websites or through research at the library. Property owners also have the option to hire a

professional paint testing company to perform a paint analysis from samples taken at the home to determine the original colors.



Example of an incompatible infill (center structure) utilizing inappropriate materials and color that do not match the red brick of the neighboring commercial structures. This infill also does not match the pattern (repetitive elements of the windows and storefronts) or massing (height) of the adjacent buildings.



Top: House before new paint scheme, Kansas City, MO , 1998. Below: House after new historically appropriate color scheme. Kansas City, MO 1998.

Primary Buildings

The appearance of new construction should compliment adjacent historic structures without replicating them. A new building should stand out as new, while adhering to the historic qualities of the neighborhood.

Size, scale, mass, proportion, pattern and alignment are all important factors in new construction so that new primary buildings respect the nature of the historic district.

New design should relate to character-defining elements in the neighborhood and adhere to neighborhood patterns. For example, if all of the historic buildings are two stories, new construction should also be two stories. New construction should also follow setback requirements.

New buildings should be constructed of materials similar to the building materials found throughout the neighborhood. A new stucco-clad house would not be appropriate placed on a neighborhood block of wood clapboard houses.

The appearance of new construction should take cues from its surrounding context and reinforce the historic buildings in the neighborhood without directly copying another building.



Above: Example of a new house constructed within the historic district., 314 East Excelsior, 2014. The new houses references the historic materials, architectural features and color palette from the existing neighborhood. 2014. Below: Historic home located within the historic district, 432 Isley Boulevard, 2014.

Primary Buildings

Recommended:

- New construction should maintain the same setbacks as the existing houses in the neighborhood.
- New construction should be proportional in size, scale, mass and form to the adjacent historic houses in the neighborhood.
- New construction is encouraged to take into consideration the materials of the historic houses in the neighborhood. (siding, windows, roofing, masonry, etc.)
- New construction is encouraged to have a historically appropriate color scheme.

Not Recommended:

- New construction of a house that is so large it dwarfs the other houses in the neighborhood.
- New construction that does not follow the same setbacks as the existing houses in the neighborhood (including front, side and back yards).
- New construction that is of a dramatically different in terms of scale, massing, form and materials of the adjacent historic houses in the neighborhood.

What is considered Maintenance and what requires a COA?

COA:

- New house construction.
- Lot improvements (including regarding, fill or landscaping).
- New sidewalks and driveways.

Outbuildings

Outbuildings are defined as a building, such as a shed, barn, playhouse, garage or carriage house located on the same property, but separate from the primary structure. Existing outbuildings (playhouses, garages and carriage houses) within the Boarding House Historic District are typically placed in the rear of the lot, not easily visible from the street. Garage access is primarily from a driveway at the front of each lot, through the property, to the detached garage near the rear of the property. Garages are located at least partially behind the main residence and are typically detached from the house. The garages do not visually compete with the main house. New garage designs should follow these historic precedents.

Traditionally, if a house had a rear outbuilding it was a carriage house, not a garage. Carriage houses are typically larger than garages and were usually divided into three spaces. One large space which held the carriage was located next to another area for the horses. Above these spaces was one large space used as a hay loft. Automobiles are much smaller than carriages and require less storage space. Carriage houses and garages are typically proportional in size, massing and scale, and generally reflect the style and materials of the house they serve.

In today's world it is often necessary to have outbuildings to store cars, yard equipment and countless other necessities. However, modern structures are often utility centered and do not aesthetically blend with historic structures. They can be disproportionately large and bulky when built next to existing historic buildings. New outbuildings, like historic outbuildings, should complement the existing structure and should be similar in scale, proportion,



Example of a new garage with historic home in the background. New garage resembles the historic home in size, scale, form and materials and detailing.
Liberty, MO , 2009.

style, color, materials and should have the same roof shape as the existing building. Additionally, the new outbuilding should be similar to the other outbuildings in the neighborhood. For example, if the majority of the existing outbuildings in the neighborhood are single car garages, a three car garage would be inappropriate, for it is dramatically different in scale and proportion of the existing structures. When designing a new outbuilding, keep the Secretary of the Interior's Standards for Rehabilitation in mind.

The design as a whole should incorporate the details of the historic buildings it will be next to. Details such as cornice molding need not be as elaborate as the detail on the existing structure, but similar details can be achieved with moderate investment. Note that just applying fancy moldings to a prefabricated modern looking garage will not suffice and will look out of place. All features of the new outbuilding including doors, windows, and the like, should also take into consideration the historic character of the existing building and be of similar material, color, style, size and have minimal street visibility.

Mobile homes, modular homes, metal buildings, pole barns, concrete block buildings and pre-fabricated buildings are not allowed.

Any building or outbuilding moved into Excelsior Springs will be treated as new construction and is subject to the same design guidelines.

Outbuildings

Recommended:

- Historic garages or outbuildings are highly encouraged to be restored.
- New garages or outbuildings should be located to the rear of a property, not visible from the public right of way.
- Size, scale and overall design of the outbuilding or garage should resemble that of the house .
- All garages and outbuildings (regardless if it is historic or new construction) must be painted or stained to match the house.

Not Recommended:

- Do not demolish a historic garage or outbuilding unless it is too deteriorated to restore.
- Do not install metal or fiberglass carports.

What is considered Maintenance and what requires a COA?

Maintenance:

- Touch up painting of existing garage or other outbuilding with the same color it is currently painted.
- Minor repairs to existing outbuildings.

COA:

- Any building that is permanent (has a footing/foundation) in its construction or that requires a building permit shall be reviewed by the Preservation Commission (includes new garages, sheds, barns, etc.).
- Reconstruction of whole or part of an existing structure (includes garages, carriage houses, sheds, barns, etc.).
- Installation of new doors, garage doors, windows, roofing, siding, or masonry in outbuildings (if visible from the public-right-of-way).
- Lot improvements (including regarding, fill or landscaping).
- New sidewalks and driveways.

Additions

New additions are often desired to enlarge a space or add to the overall square footage of a home. Per the Secretary of the Interior's Standards for Rehabilitation, additions should be located to the rear of the building or on a secondary façade and should not destroy historic materials that characterize the property. New work should be differentiated from the old and be compatible with the massing, size, scale, and architectural features to protect the historic integrity of the property and its environment. New additions and adjacent or related new construction should be undertaken in such a manner that if removed in the future, the essential form and integrity of the historic property and its environment would still be intact.

Additions

Recommended:

- Place additions to the rear of the property or on a secondary facade.
- Side additions should not compete with the primary structure and should be minimally or not visible at all from the street (public right-of-way).
- Additions should be compatible with the existing house.
- New additions should be designed in a manner that if removed in the future, the form and integrity of the historic structure will still be intact.
- Additions should be smaller than the existing house
- Keep additions simple and appropriate in shape, materials, color and detail.
- Keep the massing, size and proportion of the addition so that it does not compete with the existing property.



Top Left: Image of house before new addition. Kansas City, MO, 1998.
Below Right: Image of house after new addition. Kansas City, MO, 1998.

Not Recommended:

- New construction of an addition that is larger than the existing house and neighboring houses.
- New construction of an addition on the primary or front façade of a building.
- New construction that is of a dramatically different in terms of scale, massing, form and materials of the adjacent historic houses in the neighborhood.

What is considered Maintenance and what requires a COA?**Maintenance:**

- Touch up painting of existing addition with the same color it is currently painted.
- Minor repairs to existing addition.

COA:

- Any building addition shall be reviewed by the Preservation Commission.
- Reconstruction of whole or part of an existing structure (includes garages, carriage houses, sheds, barns, etc.).
- Installation of new doors, garage doors, windows, roofing, siding, or masonry in outbuildings (if visible from the public-right-of-way).
- Lot improvements (including regarding, fill or landscaping).
- New sidewalks and driveways.



Top: Image of a deteriorated rear stair on a colonnade apartment building. Kansas City, MO, 2000.

Below: Image of the new rear stair addition. The new stair was reconfigured to meet current building code requirements yet its design compatible with the historic structure. Kansas City, MO, 2000.

Introduction

Historic designation, either local or national, does not protect historic resources from demolition. Demolition requests for buildings or structures within the locally designated historic district or demolition of a historic landmark always requires Historic Preservation Commission review prior to issuance of a permit. In order to expedite this process, the City Planning and Zoning Department Staff reviews each demolition permit that is applied for. If the property is located within a historic district, the demolition request must also be reviewed by the Historic Preservation Commission prior to issuance of a demolition permit.

Demolition of a historic building, outbuilding, or accessory structure should only be considered when the building is so deteriorated that it is no longer safe to occupy and cannot be rehabilitated. It is up to the property owner to show proof of structural stability or evidence of severe deterioration, associated rehabilitation costs if the building was put back into service, and evidence that maintenance was not deferred by the current property owner. A structural report prepared by a professional may be used to substantiate the owner's request for demolition.

Each demolition request is evaluated on a case-by-case / property-by-property basis by the City Staff and the Historic Preservation Commission.

Demolition By Neglect

“Demolition by neglect” is one of the most serious threats to the preservation of the City's historic resources. According to the National Trust for Historic Preservation, “demolition by neglect” is defined as, “a situation in which a property owner intentionally allows a historic property to suffer severe deterioration, potentially beyond the point of repair.” This not only applies to the demolition of houses and commercial buildings, but also outbuildings, barns, carriage houses, garages, retaining walls, etc. While there can be numerous reasons not to address maintenance issues on a building, the intentional withholding of basic maintenance and repair to any building is prohibited.

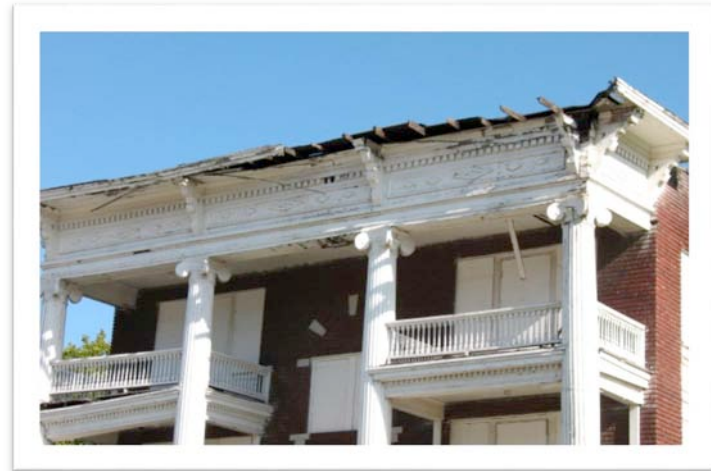

Example of heavily deteriorated porch cornice, Kansas City, Missouri, 2012. There are still good pieces of the cornice can be used to make replacement pieces and is not too deteriorated to warrant demolition.

Specific situations may require different or alternative solutions. The City is willing to consider any suggestions for temporary or long-term solutions so long as they adequately address the problems that have created the deteriorated condition. The City's maintenance ordinance provides guidance on what is considered maintenance and timeframes for compliance.



Top Right: Picture of a structurally unsound portion of a brick building addition. The remainder of the building is in good condition. Thus, only the addition required a Certificate of Appropriateness for demolition, Kansas City, 2009.



Right: Photograph of a historic house after a non-historic addition was removed. The outline of the single story addition is still visible as a dark outline on the brick during rehabilitation, Kirksville, MO, 2005.

Mothballing

If a historic building is not in use, is sitting vacant and funding is not currently available to restore or rehabilitate a building into a usable condition, it may be necessary to temporarily protect it from weather and vandalism by securing the building with temporary coverings.

This process, known as mothballing, can be a necessary and effective means of protecting the building while raising money and planning for the building's future use. This course of action is acceptable only when the lack of attention does not result in the further deterioration of the building or its unique architectural features. If the building is vacant, it should be boarded and secured from public access.

For a temporary solution to broken or missing doors and windows, secure a painted piece of plywood or carefully fitted metal panels onto the building.

NOTE: The Historic Preservation Commission can never override a decision by the Building Official if a building or structure poses a life or safety issue.

If a building/structure is tagged for an “emergency demolition”, meaning an immediate threat to the public’s safety and in imminent danger of collapse, no Historic Preservation Commission review is required.

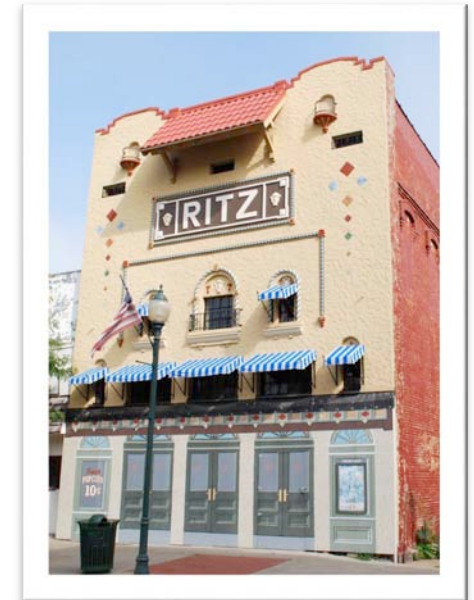
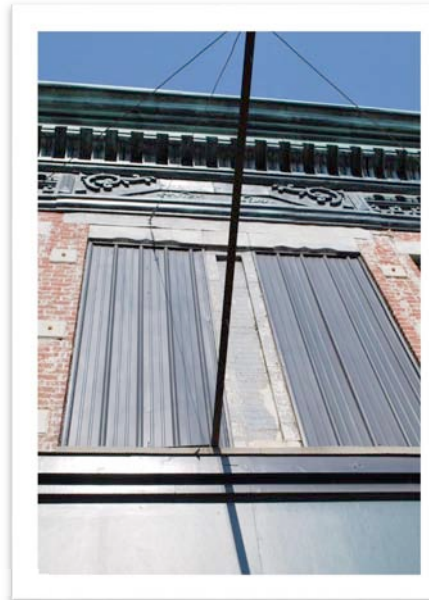

Left: Example of temporary mothball treatment . The metal coverings are neatly fit over the historic wood windows underneath providing protection from the elements until the building can be rehabilitated. Joplin, MO 2010. Right: View of painted plywood mothball treatment makes the temporary covering more aesthetically pleasing, Centerville, IA, 2009.

References:

Preservation Brief 31: *Mothballing Historic Buildings*

The covering should fit tightly inside the frame of the window or door on the exterior of the building. Avoid unnecessary screws, nails or other fasteners into historic exterior siding or masonry. Painting the coverings over windows and doors is encouraged to provide a better looking installation. The coverings can even be painted to look like the original windows and doors for an even better looking temporary installation.

A building cannot stay indefinitely in a deactivated or mothballed state and should be regularly checked for leaks, structural deterioration and should have security protection, have some form of interior ventilation (mechanical fans or louvered vents through windows), and should continue to be maintained to keep the building intact.



View of a rear stair enclosure in need of repair. The majority of the deterioration to the porch is from weather and water. Kansas City, MO, 2000.

Recommended Corrective Measures to Avoid Demolition

There are any number of problems that can lead to the deterioration of a building. The following is a general list of some of the most common problems with some suggested solutions:

Roof, Gutters, Downspouts, and Flashing

The roofing, gutters, downspouts and flashings are the most important elements in protecting a building from water damage and deterioration. Water is one of the most damaging elements on a building and keeping water out of the building should be the highest priority. It is recommended to make repairs to the roofing and drainage systems to match the original in material and detail. Flashings and counterflashings are critical components of a roofing system and should be checked annually for deterioration. Flashings are typically pieces of metal installed where the roof meets a chimney, dormer, or other change in the roof line or roof pitch. They are the first line of defense against water penetrating into the underlayment or interior of the building.

If roof damage is so extensive or if other structural repairs are required, it may be necessary to replace the entire roof structure or roof underlayment with new plywood and re-roof the structure.

Broken or Missing Glazing, and Open or Missing Windows or Doors

Missing or broken windows and doors can allow water infiltration and

unwanted public access. If left unchecked, water will ruin, potentially irreversibly, the interior and exterior of the building. A building with open doors or windows is also an invitation to vandals and vagrants to enter and possibly damage the building. If a building is missing doors or windows, or if it is abandoned, the City requires that the building openings be boarded up with painted plywood or metal panels and that any loose debris be removed.

Missing Exterior Finish Materials

Exterior finish material such as siding, trim, fascia, soffits, and window casings provide a weather barrier as well as protection for interior finishes. These elements also often carry important architectural features that help define the style and age of the building. When repairing loose or missing exterior finish material, it is important not to damage or remove any of the other existing historic building materials. Where replacement material is necessary, it must match the original in material in-kind. All replacement materials should be maintained after installation and checked for damage every year to ensure the repairs will last.

Structural Failure

Structural instability of a building or a portion thereof, is often the most difficult condition to accurately diagnose and find the root cause of the problem. If the structural stability is serious, a professional structural engineer should be hired to determine the extent of the damage and the measures necessary to correct it.

If the condition of the building has deteriorated to the point that the building or a portion of the building cannot be saved, it is sometimes reasonable to propose demolition of the structurally unsound portion of the building as a

means of “correcting” the structural failure. The Historic Preservation Commission will consider the root of the problem that caused the structural failure and what the proposed demolition will look like when completed as they are reviewing such a request.

Recommended:

- Maintain buildings and outbuildings on a regular basis in order to prevent a small problem from growing into a bigger one.
- If demolition is the only solution and the building, it is recommended to photographically document the building and interior (if possible, do not enter a structurally unsound building) and include the information in the certificate of appropriateness for demolition.
 - This not only documents the conditions of the building, but also can be made part of the public record documenting the building for potential future research.
- If your building is still structurally sound but is not in a usable condition, it is recommended to mothball the structure with neatly cut and well fitting coverings until funding can be assembled to restore or rehabilitate the building to correct the condition.
 - Painting the temporary coverings (plywood or metal) is highly recommended, including painting the coverings to look like the windows and doors underneath.

Not Recommended:

- Demolishing a building in order to have the lot to build a new building on.
- Demolishing a building or outbuilding for a new building addition on an adjacent structure.
- Demolishing a building that is within the Boarding House Historic District without going through the Certificate of Appropriateness process .

What is considered Maintenance and what requires a CoA?

Maintenance:

- Minor repairs to the existing building (refer to Chapter 5 for additional information and guidance regarding different materials and architectural elements).

CoA:

- Demolition of any structure located within a historic district (including a house, a commercial building, church, school, library, etc.)
- Demolition of an outbuilding or garage.
- Demolition of large trees.
- Demolition of a character defining element (porches, railings, additions, etc.)
- Demolition of a portion of a structure.



Top: View of mothballed house, ready for rehabilitation. Lawrence, KS, 2009. Below: View of structurally unsound roof structure on a historic outbuilding. The rest of the structure is in good condition, therefore only select demolition of the deteriorated roof structure is needed and can be repaired and saved. Boonville, MO 2009.



Bibliography

- American Institute of Architects. *Architectural Graphic Standards*. Ed. Bruce Bassler. Student Edition ed. New York: John Wiley & Sons, 2000. Print.
- Ching, Francis D.K. *A Visual Dictionary of Architecture*. New York: van Nostrand Reinhold, 1995.
- McAlester, Virginia Savage. *A Field Guide to American Houses*. Second Edition. New York: Alfred A. Knopf, 2013.
- Phillips, Steven J. *Old-House Dictionary*. Washington, D.C.: Preservation, National Trust for Historic Preservation, 1994. Print.
- State Historic Preservation Office, Missouri Department of Natural Resources. *Instructions for Completing the Architectural/Historic Inventory Form*.

Resources

The following list is provided as a guide to the resources available which offer more detailed information concerning the appropriate treatment and methods for renovation and restoration projects.

National Park Service

Secretary of the Interior's Standards:

- <http://www.nps.gov/tps/standards.htm>

Guidelines for the Treatment of Historic Properties

- <http://www.nps.gov/tps/standards/four-treatments/standguide/index.htm>

Interpreting the Standards Bulletins:

- <http://www.nps.gov/tps/standards/applying-rehabilitation/standards-bulletins.htm>
- #4. Exterior Doors
- #9 Porch Alterations
- #23 Selecting New Windows
- #37 Rear Additions to Historic Houses
- #53 New Additions to Provide Accessibility

National Park Service Preservation Briefs:

<http://www.nps.gov/tps/how-to-preserve/briefs.htm>

Listed below are the applicable technical preservation briefs for residential historic properties included within these design guidelines:

- #1 Cleaning and Water-Repellent Treatments for Historic Masonry Buildings
- #2 Repointing Mortar Joints in Historic Masonry Buildings
- #3 Improving Energy Efficiency in Historic Buildings
- #4 Roofing for Historic Buildings
- #8 Aluminum and Vinyl Siding on Historic Buildings: The Appropriateness of Substitute Materials for Resurfacing Historic Wood Frame Buildings
- #9 The Repair of Historic Wooden Windows
- #10 Exterior Paint Problems on Historic Woodwork
- #14 New Exterior Additions to Historic Buildings: Preservation Concerns
- #16 The Use of Substitute Materials on Historic Building Exteriors
- #17 Architectural Character—Identifying the Visual Aspects of Historic Buildings as an Aid to Preserving their Character
- #21 Repairing Historic Flat Plaster—Walls and Ceilings
- #24 Heating, Ventilating, and Cooling Historic Buildings: Problems and Recommended Approaches
- #31 Mothballing Historic Buildings
- #39 Holding the Line: Controlling Unwanted Moisture in Historic Buildings
- #45 Preserving Historic Wooden Porches
- #47 Maintaining the Exterior of Small and Medium Size Historic Buildings

Secretary of the Interior's Standards for Rehabilitation:

Rehabilitation is defined as the act or process of making possible a compatible use for a property through repair, alterations, and additions while preserving those portions or features which convey its historical, cultural, or architectural values.

Rehabilitation as a treatment

When repair and replacement of deteriorated features are necessary; when alterations or additions to the property are planned for a new or continued use; and when its depiction at a particular period of time is not appropriate, Rehabilitation may be considered as a treatment.

1. A property will be used as it was historically or be given a new use that requires minimal change to its distinctive materials, features, spaces, and spatial relationships.
2. The historic character of a property will be retained and preserved. The removal of distinctive materials or alteration of features, spaces, and spatial relationships that characterize a property will be avoided.
3. Each property will be recognized as a physical record of its time, place, and use. Changes that create a false sense of historical development, such as adding conjectural features or elements from other historic properties, will not be undertaken.
4. Changes to a property that have acquired historic significance in their own right will be retained and preserved.
5. Distinctive materials, features, finishes, and construction techniques or examples of craftsmanship that characterize a property will be preserved.



6. Deteriorated historic features will be repaired rather than replaced. Where the severity of deterioration requires replacement of a distinctive feature, the new feature will match the old in design, color, texture, and, where possible, materials. Replacement of missing features will be substantiated by documentary and physical evidence.
7. Chemical or physical treatments, if appropriate, will be undertaken using the gentlest means possible. Treatments that cause damage to historic materials will not be used.
8. Archeological resources will be protected and preserved in place. If such resources must be disturbed, mitigation measures will be undertaken.
9. New additions, exterior alterations, or related new construction will not destroy historic materials, features, and spatial relationships that characterize the property. The new work will be differentiated from the old and will be compatible with the historic materials, features, size, scale and proportion, and massing to protect the integrity of the property and its environment.
10. New additions and adjacent or related new construction will be undertaken in such a manner that, if removed in the future, the essential form and integrity of the historic property and its environment would be unimpaired.

LOCAL INFORMATION AND CONTACTS

The Historic Preservation Commission was formed in 2007 to review proposed work on locally listed historic properties, properties located within historic districts and to promote the preservation of the community. The Commission meets the second Wednesday of each month. Certificate of Appropriateness Applications for proposed changes to historic properties may be picked up at the City of Excelsior Springs or downloaded from the City's website. Questions to the Commission may be directed to the City Planning and Zoning Director at: 816-630-0756.

For all new construction and some rehabilitation projects, whether it is a small addition or structural changes to a building, permits may be required. Reviews of plans and specifications will be done by the City of Excelsior Springs Building Codes Department. These guidelines are not meant to replace any required local or state building codes, but are a supplemental tool to assist in historically appropriate design and aesthetics.

MISSOURI DEPARTMENT OF NATURAL RESOURCES- STATE HISTORIC PRESERVATION OFFICE

Mailing Address: P. O. Box 176
Jefferson City, MO 65102
Phone: 1-800-334-6946 or
(573) 751-7858
E-mail: moshpo@dnr.mo.gov

MISSOURI ALLIANCE FOR HISTORIC PRESERVATION

Website: <http://www.preservemo.org>

Mailing Address: Missouri Preservation
P.O. Box 1715
Columbia, MO 65205-1715
Phone: (573)443-5946
E-mail: preservemo10@yahoo.com

THE NATIONAL PARK SERVICE: LOCAL HISTORIC DISTRICTS

Websites:
<http://www.nps.gov/history/hps/workingonthepast>
<http://www.nps.gov/history/HPS/workingonthepast/definehd.htm>
<http://www.nps.gov/history/hps/workingonthepast/roletheyplay.htm>

THE NATIONAL PARK SERVICE: THE SECRETARY OF THE INTERIOR'S STANDARDS FOR THE TREATMENT OF HISTORIC PROPERTIES

Website:
http://www.nps.gov/history/hps/tps/standards_guidelines.htm

Mailing Address: Department of the Interior
1849 C Street, N.W.
Washington DC 20240
Phone: (202)-208-3100



OLD HOUSE JOURNAL

Website: <http://www.oldhousejournal.com>

THE NATIONAL PARK SERVICE: LINKS TO THE PAST

Website:
<http://www.nps.gov/history/preservation.htm>
<http://www.nps.gov/history>

THE NATIONAL PARK SERVICE: TECHNICAL PRESERVATION SERVICES FOR HISTORIC BUILDINGS

Website:
<http://www.nps.gov/history/hps/tps/briefs/presbhom.htm>

THE NATIONAL TRUST FOR HISTORIC PRESERVATION

Website: <http://www.preservationnation.org>
Mailing Address: 1785 Massachusetts Ave., NW
Washington, DC 20036-2117
Phone: (202)-588-6000

FINANCIAL INCENTIVES

Missouri State Historic Preservation Tax Credit Program

Owners of historic properties (commercial and residential) in the State of Missouri (not-for-profit entities and government entities are ineligible) are eligible to receive state tax credits equal to 25% of eligible costs and expenses of the rehabilitation of approved historic structures. Properties must be listed individually on the National Register of Historic Places; certified by the Missouri Department of Natural Resources as contributing to the historical significance of a historic district listed on the National Register; or of a local historic district that has been certified by the US Department of the Interior.

Refer to the following web site for more information:

<http://www.dnr.mo.gov/shpo/TaxCrds.htm>

Federal Historic Rehabilitation Tax Credits

20% Rehabilitation Tax Credit:

Buildings must be individually listed or contributing in a Historic District on the National Register of Historic Places; or the building must be determined to be 'eligible' by the State Historic Preservation Office for individual listing

in the National Register; or the building may be included in the local certified historic district or in a historic district that is potentially eligible for listing in the National Register to qualify for the credit. The historic building must be used for an income-producing purpose for at least five years after the rehabilitation. Owner-occupied residential properties do not qualify for the federal rehabilitation tax credit.

Refer to the following web site for more information:

<http://tps.cr.nps.gov/status/>

10% Tax Credit:

For buildings placed in service prior to 1936, a 10% rehabilitation tax credit is available. It does not include enlargement or new construction. Buildings may not be on the National Register of Historic Places or must be certified as 'non-contributing' within a National Register Historic District by the Department of the Interior National Park Service.

Refer to the following website for more information:

<http://www.irs.gov/businesses/small/industries/article/0,,id=97599,00.html>

Glossary

Abut

To adjoin at an end; to be contiguous.

ADA

A 1990 Federal law that mandates all public buildings are accessible to all people with any type of physical handicaps. (The Americans with Disabilities Act of 1990).

Adjacent

To physically touch or border upon, or to share a common property line or border. Includes properties or uses that are separated by a drive, street, or other public-dedicated right-of-way.

Alignment

Alignment is the linear relationship of structures creating a visual line and a sense of continuity along the streetscape.

Alteration

Any act or process that changes one or more of the exterior architectural features of a building or structure, including, but not limited to, the erection, construction, reconstruction, removal, demolition, or moving of any building, structure or utility.

Arch

A curved and sometimes pointed structural member used to span an opening.

Archaeological Site

Earthworks, any subsurface remains of historical, archaeological or architectural importance, or any unusual ground formations of archaeological significance.

Architectural Style

Useful tools for analyzing general types of historic resources that tend to be related to the building's era of construction and popular regional trends. *See Chapter 4 for more information about Architectural Styles.*

Ashlar

Ashlar is a squared or rectangular building stone pattern.

Awning

A projecting roof-like structure sheltering a door or window, often canvas.

Balcony

A railed projecting platform found above ground level on a building.

Baluster

An upright member of closely spaced supports for a railing or bannister.

Balustrade

A balustrade is a railing composed of balusters and a handrail, often used for porch and stair railings.

Bargeboard

A bargeboard is a board, typically decorative, which hangs from the eaves or in a gable of a building.

Beltcourse

The horizontal element that runs the length of the building, typically dividing stories of a multiple story building.

Bay

A bay is a part of a building separated by vertical elements such as windows or doors.

Bay Window

A bay window is a window which protrudes from the regular building facade.

Block

The properties abutting both sides of a street and lying between the two nearest intersecting or intercepting streets.

A molding or projecting course running horizontally along the face of a building, such as a continuous row or layer of stones or brick in a wall.

Board and Batten Siding

Siding consisting of wide boards or plywood sheets set vertically with butt joints covered by battens.

Bond

The pattern or arrangement of bricks within a wall.

Bracket

A projecting support used under cornices, eaves, balconies, or windows to provide structural or visual support. A flat bracket is called a *Modillion*.

Brick

A building or paving unit made of fired clay, usually rectangular in shape.

Brick Mold

A wood molding covering the gap between a doorframe or window frame and the masonry reveal into which the frame is set.

Building Official

The official who is charged with the administration and enforcement of the City's Building Code.

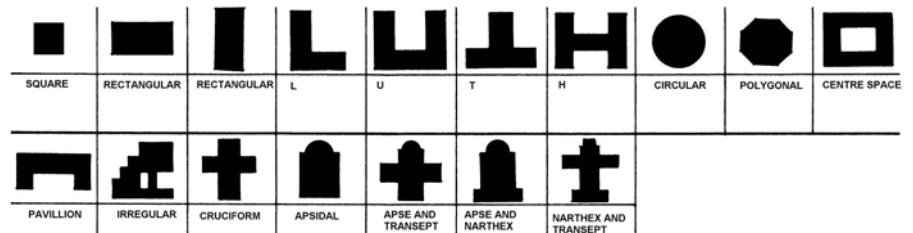
Building Plans

Courtesy of Missouri State Historic Preservation Office *Instructions for Completing the Architectural/ Historic Inventory Form.*

Bulkhead

The area under a storefront window. Also, a structure covering a stairwell or other opening, to provide adequate headroom.

Canopy

A projection over a niche or doorway; often decorative or decorated.

Capital

A capital is the decorative top of a column or pilaster.

Casement Window

A window sash that swings open along its entire length; usually on hinges fixed to the sides of the opening into which it is fitted.

Character

The attributes, qualities, and features that make up and distinguish a development project and give such project a sense of purpose, function, definition, and uniqueness.

Clapboards

Clapboards are a traditional wooden siding consisting of horizontal, overlapping wooden beveled boards which are usually four to six inches wide.

Certificate of Appropriateness Application (COA)

A design permit issued by the City Planning and Zoning Department and Building Inspector, indicating approval of the plans for alteration, construction, removal or demolition of a Landmark or of a structure within a Historic District. The application describes proposed changes to a property and is submitted to the Historic Preservation Commission for review and approval prior to the initiation of any work. A Certificate will be denied for any work on a building that would destroy, alter or remove significant exterior architectural features or construction element. *See Chapter 3 for*

more information about the application process and when it is necessary.

Column

A vertical support; in classical architecture, the column has three parts, base, shaft, and capital. Sometimes columns are not structural and are for decorative purposes.

Compatible

Consistent, congruous; referring specifically to new additions to historic resources. *See Chapter 8 for more information about considerations for new construction.*

Concrete Block

A hollow or solid concrete masonry unit consisting of cement and suitable aggregates combined with water.

Concrete Slab

A flat, rectangular, reinforced concrete structural member; especially used for floors and roofs.

Concrete

Made by mixing cement or mortar with water and various aggregates such as sand, gravel, or pebbles.

Contributing (Resource/Property)

A building, site, structure, or object within a historic district that adds to the values or qualities of that district because it was present during the period of significance and possesses historical integrity, or it independently meets National Register of Historic Places criteria.

Coping

The protective uppermost course of a wall or parapet.

Corbeling

Brick or masonry units that step out in a decorative fashion, sometimes to support a cornice or other element.

Corner Board

A corner board is a narrow vertical board placed on corners of buildings to terminate the wooden clapboards.

Cornice

A cornice is an ornamental moulding along the top of a building. It typically protrudes from the building in order to make it stand out; The exterior trim where the wall meets the roof is also called a cornice.

Cottage Window

A double-hung window with an upper sash smaller than the lower sash.

Cultural Resources

Districts, sites, structures, landscape elements and objects that show evidence of some importance to a culture, a subculture, or a community for scientific, engineering, art tradition, religious, or other reasons, significant in providing interpretation of past life ways and for interpreting human behavior.

Cupola

A cupola is a small, domed or pointed roof structure located at the top of a roof.

Demolition

Any act or process which destroys, in part or in whole, a building or a structure.

Dentils

A series of closely spaced, small, rectangular blocks, used especially in classical architecture.

Design Guidelines

A standard by which appropriate repairs, maintenance and rehabilitation construction activity will preserve/maintain the historic and architectural character of a building, structure or area.

Display Window

A window of a store facing onto the public right-of-way used to display merchandise for sale in the store.

Dormer

A dormer is a structure which protrudes from the roof, usually containing a window; a vertically set window on a sloping roof; also the roofed structure housing such a window.

Double-Hung Window

A window of two (or more) sash where one sash slides vertically past the other in order to open the window. Sashes are glazed frames, set in vertically grooved frames or jambs in a building opening and capable of being raised or lowered independently of each other.

**Eaves**

The underside of the roof that projects past the wall of a building.

Elevation

An elevation is any external face of a building.

Entablature

The horizontal beam carried by a column. It is horizontally divided into three parts. A horizontal, continuous lintel on a classical building supported by columns or a wall, comprised of the architrave, frieze, and cornice.

Exterior Architectural Appearance

The character and general composition of the exterior of a building or structure including, but not limited to: the type and texture of the building material, the design and character of all elements visible from the exterior such as windows, doors, siding, trim, roofs, porches, balconies, landscaping and ornamentation.

Exterior Insulated Finish Systems (EIFS)

A type of building exterior wall cladding system that provides exterior walls with an insulated finished surface and waterproofing in an integrated composite material system intended to simulate the texture and appearance of actual stucco.

Façade

An exterior elevation or wall of a building, usually a principal elevation.

Fanlight

An arched window with muntins that radiate like a fan; used as a transom.

Fascia

A horizontal member or board that covers the rafter ends along the edge of the roof.

Fenestration

The composition of windows and door openings on a wall.

Fiberboard

An insulating board made of wood or cane fibers compressed and cemented into rigid sheets, used as an inexpensive wall finish

Finial

A finial is the decorative element that tops a peaked element such as a gable or a post.

Flat Roof

A roof that has only enough pitch so that water can drain.

Form

The shape and structure of a building as distinguished from its substance or material.

Gabled Roof

A roof having a single slope on each side of a central ridge; usually with a gable at one or at both ends of the roof.

Gambrel Roof

A roof having a double slope on two sides of a building; the most common example is a barn roof.

Glazing

The glass area of windows or doors.

Green Space

Space that is planted with grass, plants, shrubs or trees. Sometimes, this land is set aside and cannot be built on.

Head

The uppermost member of a doorframe or window frame. The support found on the upper portion of the window or door casing is generally at least twice as thick as the framing component of the door or window and found around the opening. The header will span horizontally across the top of the door or window casing, offering added support that prevents the full weight of the wall from resting on the door or window casing itself.

Hipped Roof

A roof having adjacent flat surfaces that slope upward from all sides of the perimeter of the building.

Historic District

An area, urban or rural, defined as an historic district by city council, state, or federal authority and which may contain within definable geographic boundaries one or more buildings, objects, sites or structures designated as exceptional or significant historic landmarks or clusters, as defined herein, including their accessory buildings, fences and other appurtenances, and natural resources having historical, architectural, archaeological, and cultural significance, and which may have within its boundaries other buildings, objects, sites, or structures, that, while not of such historical, architectural, archaeological or cultural significance as to be designated landmarks,

nevertheless contribute to the overall visual setting of or characteristics of the landmark or landmarks located within the district.

Historic Preservation Commission

The seven-member commission established to assist the city in administering the Historic Preservation Ordinance. The commissioners are citizens of Excelsior Springs, appointed by the Mayor.

Historic Preservation Ordinance

The city ordinance adopted in 2005 to promote the educational, cultural, economic, and general welfare of the City of Excelsior Springs. Ordinance Section 402. *See Chapter 1 for more information about the purpose of the Historic Preservation Ordinance.*

Impervious

Roads, parking areas, buildings, pools, patios, sheds, driveways, private sidewalks, and other impermeable construction covering the natural land surface; this shall include, but not [be] limited to, all streets and pavement within the subdivision. "Percent impervious cover" is calculated as the area of impervious cover within a lot, tract, or parcel or within the total site being developed, divided by the total area within the perimeter of such lot, tract, parcel or development. Vegetated water quality basins, vegetated swales, other vegetated conveyances for overland drainage, and public sidewalks shall not be calculated as impervious cover

In-Kind or In-Kind Replacement

To replace a feature of a building with materials of the same characteristics to replicate the original element in material, dimension, texture, color and profile, etc.

Integrity

Condition or description of a property that is physically unaltered or one that retains enough of its historic character, appearance, or ambiance to be recognizable to the period when the property achieved significance.

Inventory

A listing or resources which retain levels of historic significance and integrity which includes information regarding their condition, locations, architectural details, history and areas of significance.

Jamb

Either of the vertical sides of an archway, doorway, or window opening.

Kickplate

The horizontal element or assembly at the base of a storefront parallel to a public walkway. The kickplate provides a transition between the ground and storefront glazing area.

Lap Siding

Siding composed of tapered boards, as clapboards, laid horizontally with the thicker edge of each board overlapping the thinner upper edge of the board below.

Leaded Glass Window

A window composed of pieces of glass that are held in place with lead strips; the glass can be clear, colored, or stained.

Lintel

A lintel is the horizontal beam bridging a window or door opening to carry the weight of the wall above the opening., can be timber, stone, or metal.

Lites

Glazing panes of a window or door.

Local Register

A listing and a means by which to identify, classify and recognize various sites, buildings, structures, resources and districts as archeologically, historically and/or architecturally significant.

Mass or Massing

The three-dimensional bulk of a building height, width, and depth. The measure of scale which refers to the amount of space occupied by a structure.

Masonry

A construction method that stacks masonry units, such as stones or bricks, and binds them with mortar to form a wall.

Molding or Moulding

A decorative band or strip with a profile. Generally moldings are used in cornices and as trim around a window or door opening..

Mortar

A mixture of cement, lime, sand, or other aggregates with water; used in

plastering and bricklaying.

Mothballing

Closing up a building temporarily to protect it from the weather as well as to secure it from vandalism, when all means of finding a productive use for a historic building have been exhausted or when funds are not currently available to put the deteriorating structure into a useable condition. This can protect the building while planning the property's future, or raising money for a preservation, rehabilitation, or restoration project.

Mullion

A vertical dividing member between multiple grouped windows.

Muntin

One of the thin strips of wood used to separate panes of glass within a multi-pane window.

Non-Contributing (Resource/Property)

A building, site, structure, or object within an historic district that does not add to the values or qualities of that district because it was not present during the period of significance or because it no longer retains integrity.

Orientation

Set in relation to, or adjusted to, the surroundings, situation, or environment; placed with the most important parts facing in certain directions; set or arranged in a determinate position.

Outbuilding

A building, such as a shed, barn, playhouse, garage or carriage house located on the same property, but separate from the primary structure (house).

Parapet

A low wall at the edge of a roof and are usually found on flat roofs. Can also be used to describe a or protective railing, usually used around the edge around a balcony.

Pattern

The rhythm of architectural elements on a building or structure.

Pedestrian-Oriented

Development that is designed with a primary emphasis on the street, sidewalk and/or connecting walkway access to the site and building, rather than on auto access and parking lots.

Pediment

A triangular enclosed space in the gable of a classical style building or any similar form above a door, window or portico.

Pilaster

A rectangular column or shallow pier attached to a wall.

Planting Strip

The landscaped area between the street and the sidewalk.

Porch

A covered entrance or semi-enclosed space projecting from the façade of a building; may be open sided, screened, or glass enclosed.

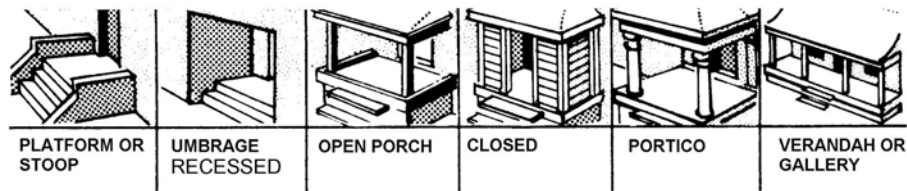

Courtesy of Missouri State Historic Preservation Office *Instructions for Completing the Architectural/ Historic Inventory Form.*

Preservation

The act or process of applying measures necessary to sustain the existing form, integrity, and materials of an historic property. Work, including preliminary measures to protect and stabilize the property, generally focuses upon the ongoing maintenance and repair of historic materials and features rather than extensive replacement and new construction. New exterior additions are not within the scope of this treatment; however, the limited and sensitive upgrading of mechanical, electrical, and plumbing systems and other code-required work to make properties functional is appropriate within a preservation project.

Primary or principal building

The building or structure on a lot used to accommodate the primary permitted use, such use possibly occurring in more than one building or structure.

Primary Façade

That portion or portions of a wall of any permanent structure that is visible from and oriented parallel to a dedicated public right-of-way. For a structure that is not oriented parallel to the right-of-way, the street wall façade shall include all of the facades visible from the right-of-way and oriented at an angle greater than zero degrees but less than 60 degrees to the right-of-way. Also referred to as Street Wall Façade.

Public Right-of-Way

An area or strip of land, either public or private, occupied or intended to be occupied by a street, walkway, railroad, utility line, drainage channel, or other similar uses.

Pyramidal Roof

A pyramid-shaped roof with four sides of equal slope and shape.

Quoins

Large or rusticated stone blocks at the corners of a masonry building.

Rafter

One of a series of structural members spanning from the ridge of the roof to the eaves, providing support for the covering of a roof.

Rail

Any of various horizontal members framing a panel, as in window with a glass panel or a door with a wood or glass panel.

Reconstruction

The act or process of depicting, by means of new construction, the form, features, and detailing of a non-surviving site, landscape, building, structure, or object for the purpose of replicating its appearance at a specific period of time and in its historic location.

Rehabilitation

The act or process of making possible a compatible use for a property through repair, alterations, and additions while preserving those portions or features which convey its historical, cultural, or architectural values.

Restoration

The act or process of accurately depicting the form, features, and character of a property as it appeared at a particular period of time by means of the removal of features from other periods in its history and reconstruction of missing features from the restoration period. The limited and sensitive upgrading of mechanical, electrical, and plumbing systems and other code-required work to make properties functional is appropriate within a restoration project.

Repointing

The act of repairing the joints of brickwork, masonry, etc., with mortar or cement.

Reveal

The part of a jamb of a window or door opening that is visible between the outer wall surface and the window or door frame.

Roof Shape

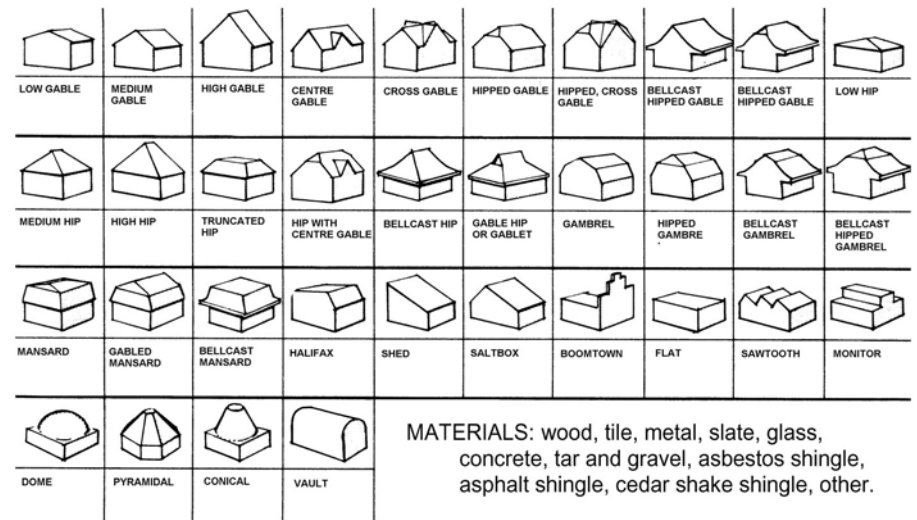

Courtesy of Missouri State Historic Preservation Office *Instructions for Completing the Architectural/Historic Inventory Form*.

Rusticated

Masonry left with a rough outer surface and wide joints that emphasize the edges of each block.

R-value

A measure of thermal resistance of a given material, used especially to specify the performance of thermal insulation. The total R-value for a building component or assembly is the sum of the R-values for each layer in the component or assembly.

Sash

A window made of one or more movable panels or "sashes" that form a frame to hold panes of glass, which are often separated from other panes (or "lights") by narrow muntins.

Scale

The size and proportion of a building as distinguished from its substance or material.

Screening

Open spaces, landscaped areas, fences, walls, or any combination thereof, used to physically separate or screen one use or property from another so as to visually shield or block noise, lights, or other nuisances.

Secondary Façade

That portion or portions of a wall of any permanent structure that is not considered a primary façade.

Secretary of the Interior’s Standards for the Treatment of Historic Properties

The Secretary of the Interior’s Standards for the Treatment of Historic Properties are intended to promote responsible preservation practices that help protect historic and cultural resources. The Standards are neither technical nor prescriptive, but once a treatment is selected, they provide philosophical consistency to the work. The four treatment approaches are Preservation, Rehabilitation, Restoration, and Reconstruction.

Setback

The open space between the property line of the lot and the nearest projection of a structure.

Shed Roof

A roof containing only one sloping plane.

Shoring

A general term used in construction to describe the process of supporting a structure in order to prevent collapse so that construction can proceed.

Side Light

A vertical window flanking a door.

Side-Gabled Roof

A gable whose face is on one side (or part of one side) of a house, perpendicular to the façade.

Sill

The horizontal member beneath a door or window opening.

Soffit

The underside of an overhanging element, such as the eaves of a roof.

Stile

Any of various vertical members framing a panel, as in a window with a glass panel or a door with a wood or glass panel.

Story

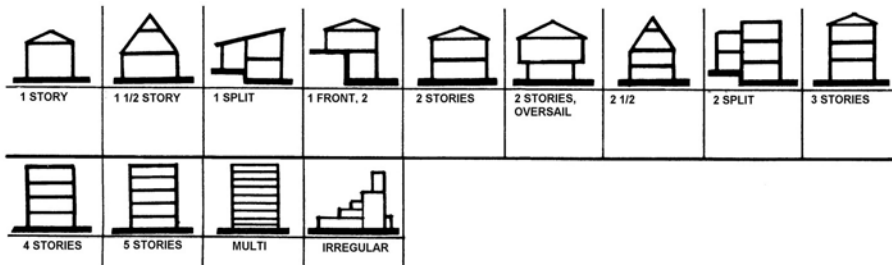

Courtesy of Missouri State Historic Preservation Office *Instructions for Completing the Architectural/Historic Inventory Form.*

Storm Window

A secondary window installed to protect and/or reinforce the main window.

Stucco

Exterior finish material composed of either Portland cement or lime and sand mixed with water.

Subordinate

Of less or secondary importance.

Transom

A horizontal window over a door or window.

Veneer

A thin layer of material, such as wood, brick, or stone, applied to a different material or to a type of construction not ordinarily associated with it, e.g. a facing of brick applied to a frame house.

Vernacular

A category of architecture based on localized needs and construction materials, and reflecting local traditions. Vernacular architecture tends to evolve over time to reflect the environmental, cultural, technological, and historical context in which it exists.

Weatherize

To make a house or building secure against cold or stormy weather, as by adding thermal insulation or storm windows, or by sealing joints.

Weather strip

A strip of metal, felt, vinyl, or foam rubber placed between a door or window sash and its frame to provide a seal against windblown rain or air infiltration.

Wing Wall

A portion of the front façade extending past the side façade, often sloping down from the eaves to the ground at an angle; a subordinate wall, one end of which is built against an abutment.



National Register of Historic Places vs. Local Register

“The National Register of Historic Places is the official list of the Nation's historic places worthy of preservation. Authorized by the National Historic Preservation Act of 1966, the National Park Service's National Register of Historic Places is part of a national program to coordinate and support public and private efforts to identify, evaluate, and protect America's historic and archeological resources.” (National Park Service Website, 2014.)

Q: How is a property locally designated?

A: You must fill out and submit a local historic landmark application form and fee for processing the application. These forms are available from the Planning Director through the City Planning and Zoning Department. The criteria for local Historic Landmark Designation are the same as those required by the National Register of Historic Places.

“The quality of significance in American history, architecture, archaeology, engineering, and culture is present in districts, sites, buildings, structures, and objects that possess integrity of location, design, setting, materials, workmanship, feeling, and association.”

The Historic Preservation Commission, following receipt of the local historic landmark application, conducts a public hearing to determine if the property is of architectural, historical and/or cultural significance. If approved, the recommendation of the Commission is forwarded to the City.

Planning and Zoning Department. The recommendations of the City Planning Director and the Historic Preservation Commission are then submitted to the City Council in the form of an ordinance. If the Council passes the ordinance, the property is listed on the local historic register. For each of the Public hearings, the applicant and/or the property owner are notified and encouraged to attend and participate in the hearings.

Refer to the attached matrix for a brief synopsis of what the different types of historic designation mean. As a planning tool, the National Register encourages preservation without public control over private property interests. Listing a property does not impose responsibilities upon the private property owner for maintenance or restoration, but can provide owners with access to financial incentives. For additional information about National Register listing, please visit the National Park Service website under the National Register : <http://www.nps.gov/nr>

Frequently Asked Questions	National Register of Historic Places
What is the National Register of Historic Places?	The National Park Service, through the Missouri Department of Natural Resources, oversees the National Register, which is a Federal list of districts, sites, buildings, structures, and objects significant in American history, architecture, archaeology, engineering, and culture. <u>Typically, buildings are evaluated for their age, integrity and significance. Meaning, buildings which are 50 years of age or older which retain the architectural character of the way it looked in the past; and those buildings not 50 years of age which are associated with a culturally significant person or event can be listed on the National Register.</u> http://www.nps.gov/nr/
Is there a benefit to being on the register?	Yes , owners may be eligible for a <u>20% Federal Historic Rehabilitation Tax Credit</u> for income-producing properties that can be combined with a <u>25% Missouri Historic Rehabilitation tax credit</u> . The Missouri tax credit applies to owner-occupied property as well. <u>There is also a 10% tax credit available for the rehabilitation of non-historic buildings placed in service before 1936.</u> The building must be rehabilitated for non-residential use. There is no formal review process for rehabilitations of non-historic buildings. http://www.nps.gov/tps/tax-incentives.htm
Do all buildings in historic districts have to be historic (50 years of age or older, or culturally significant)?	No , historic districts often include non-historic (<i>non-contributing</i>) properties. Owners of these properties are however <u>not</u> eligible for State or Federal Historic Tax Credit incentives.
Do I have any say as to whether my property is included in a historic district?	Yes , before designation all owners have the opportunity to concur with or object to listing at public hearings at the City of Excelsior Springs and the Missouri Advisory Council on Historic Preservation. <u>Designation is not permitted if the majority of property owners submit objections.</u>
Do I have to restore my property to its "original" appearance?	No , owners of private property listed in the National Register have no obligation to restore their property.
Do I have to maintain my property?	No , owners of private property listed on the National Register have no obligation to maintain their property.
What might happen to the value of my property?	Because National Register properties have some protection and tax incentives available, owners may be more inclined to make improvements to their properties, and this may <u>increase the value of all property in a given district.</u>
Where can I go for assistance?	State Historic Preservation Office P.O. Box 176 Jefferson City, Missouri 65102 Phone: (573) 751-7858 Website: http://www.dnr.mo.gov/shpo



The National Register of Historic Places Vs. Local Historic Designation

Frequently Asked Questions	National Register of Historic Places	Local Historic Landmark Designation
What are the National and the Local Historic Registers?	The National Park Service, through the Missouri Department of Natural Resources, oversees the National Register, which is a Federal list of districts, sites, buildings, structures, and objects significant in American history, architecture, archaeology, engineering, and culture.	The Historic Preservation Commission established by Excelsior Springs, Missouri oversees the Local Historic Landmark Designation process and local register of properties, which includes a list of districts, sites, buildings, structures, and significant objects contributing to Excelsior Spring's history.
Is there a benefit to being on a historic register?	Yes! Owners may be eligible for a 20% Federal Historic Rehabilitation Tax Credit for income-producing properties that can be combined with a 25% Missouri Historic Rehabilitation Tax Credit. The Missouri tax credit applies to owner-occupied property as well.	Yes! The design review process encourages quality design for proposed alterations to listed properties and gives any person or neighborhood a forum to comment on changes to their neighborhood.
Can my property be on both registers?	Yes! In addition, a property listed as both a local historic landmark and on the National Register of Historic Places may take advantage of Federal and state tax incentives and are expected to conform to national and local historic preservation standards.	
Do I have to be listed as a Local Historic Landmark before I can be on the National Register?	No , a property may be listed on <u>either register or both</u> . The local historic landmark register and the National Register of Historic Places use the same criteria to evaluate historic properties. The two historic registers are designed to compliment each other by providing unique benefits and tools to protect historic properties.	
Do all buildings in historic district have to be historic?	No , historic districts often include non-historic (<i>non-contributing</i>) properties. Owners of these properties are currently not eligible for state or Federal tax credit incentives.	No , historic districts often include non-historic (<i>non-contributing</i>) properties. However, changes to these properties are still subject to design review and approval by the Historic Preservation Commission so that proposed changes are compatible with the character of the historic district/neighborhood.

Frequently Asked Questions	National Register of Historic Places	Local Historic Landmark Designation
Do I have any say as to whether my property is included in a historic district?	Yes! Before designation, all owners have the opportunity to concur with or object to listing at public hearings with the Historic Preservation Commission and the Missouri Advisory Council on Historic Preservation. <u>Designation is not permitted if the majority of property owners submit objections.</u>	Yes! Before designation, all owners have the opportunity to concur with or object to listing at public hearings with the Historic Preservation Commission and the City Planning Commission and the City Council. <u>Designation is not permitted if the majority of property owners submit objections.</u>
Do I have to restore my property to its “original” appearance?	No , owners of private property listed on either register have no obligation to restore their property. Any changes present at the time of the property designation may remain. Features that are not existing do not have to be replicated and new ‘historic looking’ features should not be added as the alterations should not create a sense of ‘false historicism’. Any future exterior alterations will have to follow the <u>Secretary of Interior’s Standards for Rehabilitation</u> . http://www.nps.gov/tps/standards/four-treatments/treatment-rehabilitation.htm	
Do I have to maintain my property?	No , owners of private property listed on the National Register have no obligation to maintain their property.	Yes , the Excelsior Springs Preservation Ordinance and Maintenance Ordinance requires that all properties be kept in good repair, regardless of local historic landmark designation.
What might happen to the value of my property?	Because National Register properties have some protection and tax incentives available, owners may be more inclined to make improvements to their properties, and this may <u>increase the value of all property in a given district.</u>	Because local historic landmark registered properties have some protection through design review, owners may be more inclined to make appropriate improvements to their properties, and this may <u>increase the value of all property in a given district.</u>
Where can I go for assistance?	State Historic Preservation Office P.O. Box 176 Jefferson City, Missouri 65102 Phone: (573) 751-7858 Website: www.dnr.mo.gov/shpo/index.html	City of Excelsior Springs 201 E. Broadway Excelsior Springs, Missouri 64024 Phone: (816) 630-0756 Website: http://www.eshpc.org



D

GRID PAPER

Included after this page is a sheet of grid paper that you can print out and use to sketch your house and proposed exterior alterations.

Name: _____ Date: _____

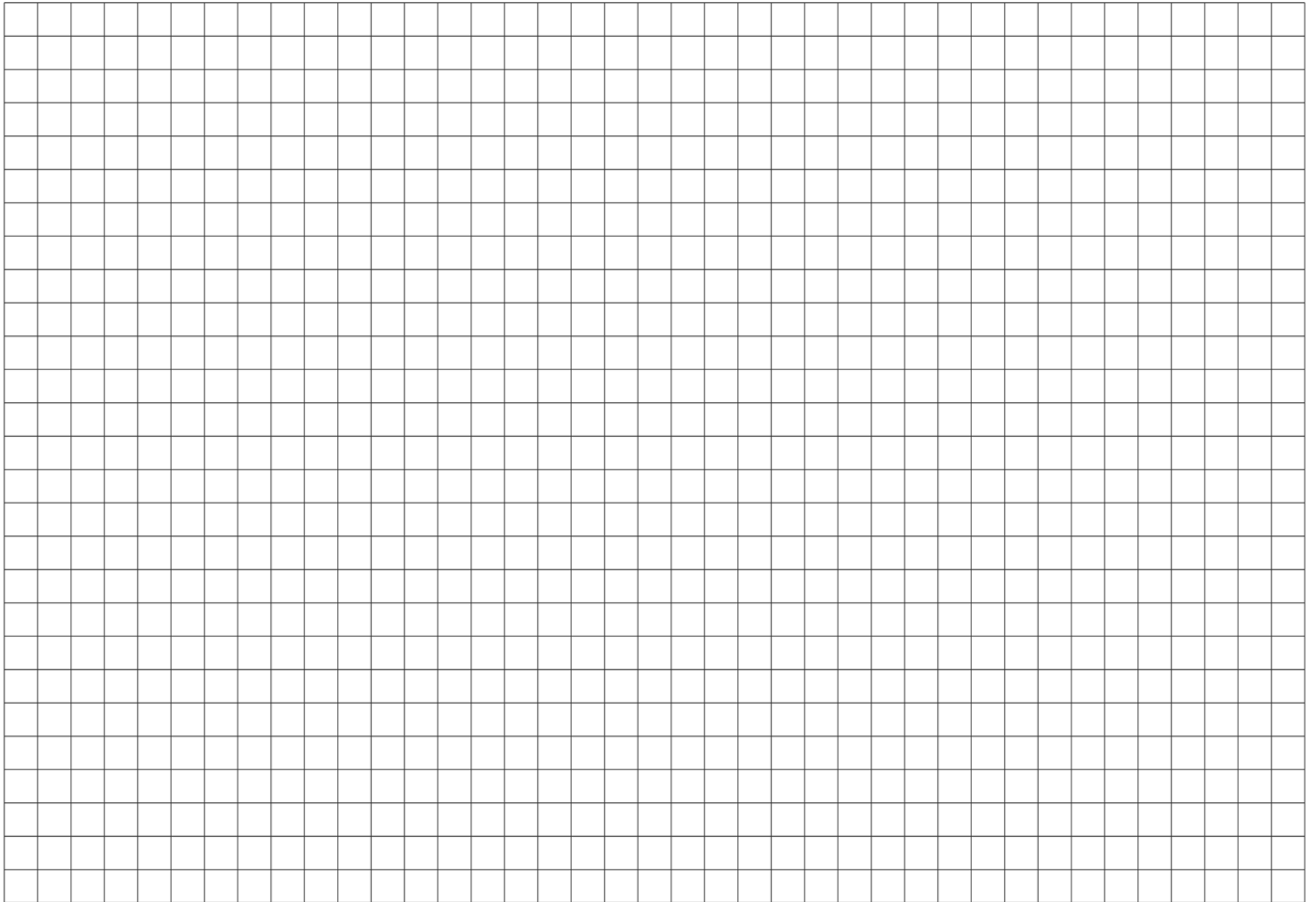

Name: _____ Date: _____

